

## COMPRESSOR DUTY MOTOR

TECO AUSTRALIA PTY LTD has been acknowledged for many years as a supplier of high quality efficient and reliable electric motors to industry.

The COMPRESSOR DUTY motor has been produced to raise the market standard in quality and performance. All motors are manufactured to current AUSTRALIAN electrical and mechanical standards and are subject to stringent quality controls which ensure the user of a high degree of reliability, backed by a full 12 month warranty.



### FEATURES:-

- Heavy duty rolled steel shell frame
- Drip proof fan cooled IP22
- Dynamically balanced rotor
- Heavy duty bearings
- Bi-directional rotation
- Pressed metal fan cover
- Pressed metal capacitor cover
- Excellent protective paint finish
- Able to withstand temporary voltage drop when starting
- Pre wired with three core flex for connection to the compressor air switch and a separate supply lead with 3 pin plug.
- Two models available -
  - 1) Capacitor start capacitor run
  - 2) PSC (Permanent split capacitor, for compressors with unloaded starting)
- Two outputs ratings for both models -
  - 1.65 kW
  - 2.2 kW
- 2 pole 2850 RPM
- B56 frame foot mounted
- Low full load currents
- Thermal overload protection
- High quality capacitors
- Single phase 240 Volt 50 Hz

# OUTLINE DIMENSIONS

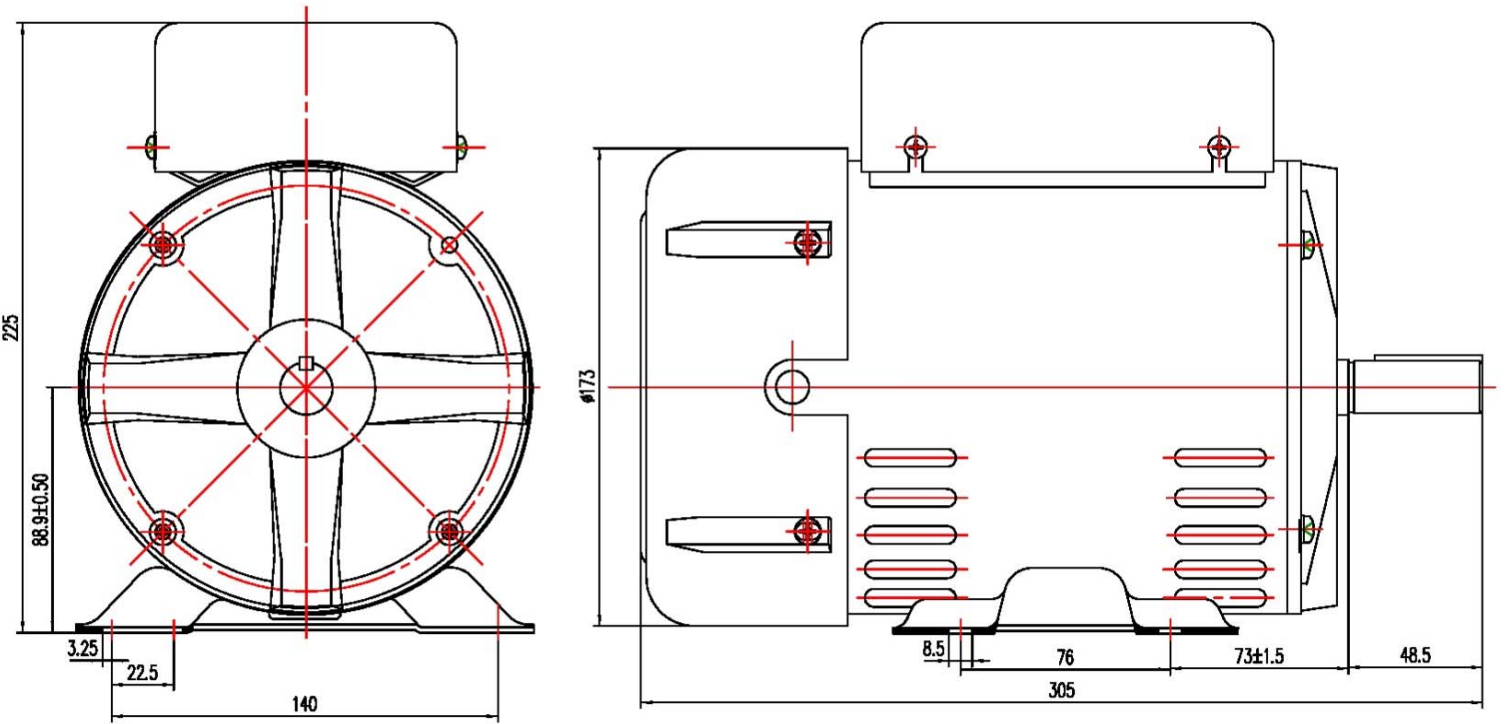

## SHAFT DETAIL

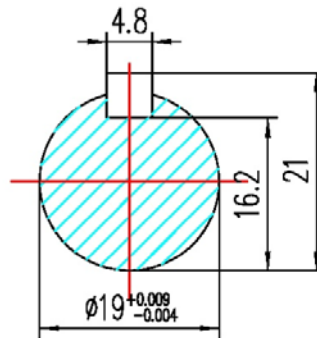

### TECO Australia Pty. Ltd.

Head Office: 335-337 Woodpark Road, Smithfield, NSW 2164  
 Brisbane Office: 50 Murdoch Circuit, Acacia Ridge, QLD 4110  
 Melbourne Office: 16 Longstaff Road, Bayswater, VIC 3153  
 Perth Office: 28 Belgravia Street, Belmont, WA 6104

Ph: (02) 9765 8118 Fax: (02) 9604 9330  
 Ph: (07) 3373 9600 Fax: (07) 3373 9699  
 Ph: (03) 9720 4411 Fax: (03) 9720 5355  
 Ph: (08) 9479 4879 Fax: (08) 9478 3876

### TECO New Zealand Ltd.

Unit 3, 477 Great South Road, Penrose, Auckland

Ph: (64) 9 526 8480 Fax: (64) 9 526 8484

Distributed by -

