

Dimension

(Unit:mm)

Model	W	H	D	W1	H1
R500AC/BC 0001AC/BC 0002BC 0001BE 0002BE 0002AC 0003AC/BC 0005BC 0003BE 0005BE 7R50BC 0010BC 7R50BE	90	163	147	78	150
JNTHBCBA 0010BE 0015BE 0015BC 0020BC 0025BC 0020BE 0025BE 0030BE 0030BC 0040BC 0040BE 0050BE 0060BE 0075BE	128	187	148	114.6	170.5
	186	260	195	173	244
	265	360	248	245	340
	269	553	304	210	530
	308	653	309	250	630

*1. IP20 Enclosure:220V 0.5~25HP/440V 1~30HP
*2. IP00 Enclosure:220V 30~40HP/440V 40~75HP

Braking Resistor

Resistor Model	Inverter Model	Specification of braking resistor W Ω	braking resistor ED%	braking torque %
150W200	R500AC/BC	150 200	10	238
150W200	0001AC/BC	150 200	10	119
150W100	0002AC/BC	150 100	10	119
260W70	0003AC/BC	260 70	10	115
390W40	0005BC	390 40	10	119
520W30	7R50BC	520 30	10	108
780W20	0010BC	780 20	10	119
150W750	0001BE	150 750	10	126
150W400	0002BE	150 400	10	119
260W250	0003BE	260 250	10	126
400W150	0005BE	400 150	10	126
600W130	7R50BE	600 130	10	102
800W100	0010BE	800 100	10	99
1R6KW50	0015BE	1600 50	10	126
2R4KW13R6	0015BC	2400 13.6	10	117
3KW10	0020BC	3000 10	10	119
4R8KW8	0025BC	4800 8	10	119
4R8KW6R8	0030BC	4800 6.8	10	117
3KW10	0040BC	3000 10	10	119
1R5KW40	0020BE	1500 40	10	119
4R8KW32	0025BE	4800 32	10	119
4R8KW27R2	0030BE	4800 27.2	10	117
6KW20	0040BE	6000 20	10	119
9R6KW16	0050BE	9600 16	10	119
9R6KW13R6	0060BE	9600 13.6	10	117
6KW20	0075BE	6000 20	10	126

NOTE: *1 The quantity of braking resistors should be 2
*2 above 25HP, please add Braking Unit : 200V JNTBU-230
400V JNTBU-430
400V JUVPHV-0060
About the detail information, please contact with your supplier

Filter

Inverter Model	Rated	Second Environment	First Environment	First Environment
		Class A (Group2)	Restricted Distribution Class A (Group1)	Unrestricted Distribution Class B
R500AC-UF	1 phase 170~264V	--	Built-in	FS 6146-11-07
0001AC-UF	1 phase 170~264V	--	Built-in	FS 6146-11-07
0002AC-UF	1 phase 170~264V	--	Built-in	FS 6146-27-07
0003AC-UF	1 phase 170~264V	--	Built-in	FS 6146-27-07
R500AC-U	1 phase 170~264V	--	FS 6146-11-07	--
0001AC-U	1 phase 170~264V	--	FS 6146-11-07	--
0002AC-U	1 phase 170~264V	--	FS 6146-27-07	--
0003AC-U	1 phase 170~264V	--	FS 6146-27-07	--
R500BC-U	3 phase 170~264V	--	FS 6147-8.9-07	--
0001BC-U	3 phase 170~264V	--	FS 6147-8.9-07	--
0002BC-U	3 phase 170~264V	--	FS 6147-8.9-07	--
0003BC-U	3 phase 170~264V	--	FS 6147-19-07	--
0005BC-U	3 phase 170~264V	--	FS 6147-19-07	--
7R50BC-U	3 phase 170~264V	--	FS 6147-39-07	--
0010BC-U	3 phase 170~264V	--	FS 6147-39-07	--
0001BE-UF	3 phase 323~528V	--	Built-in	FS 6149-4.6-07
0002BE-UF	3 phase 323~528V	--	Built-in	FS 6149-4.6-07
0003BE-UF	3 phase 323~528V	--	Built-in	FS 6149-10-07
0005BE-UF	3 phase 323~528V	--	Built-in	FS 6149-10-07
7R50BE-UF	3 phase 323~528V	--	Built-in	FS 6149-28-07
0010BE-UF	3 phase 323~528V	--	Built-in	FS 6149-28-07
0015BE-UF	3 phase 323~528V	--	Built-in	FS 6149-28-07
0001BE-U	3 phase 323~528V	--	FS 6149-4.6-07	--
0002BE-U	3 phase 323~528V	--	FS 6149-4.6-07	--
0003BE-U	3 phase 323~528V	--	FS 6149-10-07	--
0005BE-U	3 phase 323~528V	--	FS 6149-10-07	--
7R50BE-U	3 phase 323~528V	--	FS 6149-28-07	--
0010BE-U	3 phase 323~528V	--	FS 6149-28-07	--
0015BE-U	3 phase 323~528V	--	FS 6149-28-07	--
0020BE-U	3 phase 323~528V	JUNF34048S-MA	--	--
0025BE-U	3 phase 323~528V	KMF370A	--	--
0030BE-U	3 phase 323~528V	KMF370A	--	--
0040BE-U	3 phase 323~528V	KMF3100A	--	--
0050BE-U	3 phase 323~528V	KMF3100A	--	--
0060BE-U	3 phase 323~528V	KMF3150A	--	--
0075BE-U	3 phase 323~528V	KMF3180A	--	--

Extension Cable

Extension Cable Model	Digital Operator Model	Inverter Model
JNSW30P5 (0.5M)		
JNSW3001 (1M)	JNSDOP - LED	JNTHBCBA R500 - 0040AC / BC
JNSW3002 (2M)	JNSDOP - LCD	0001 - 0075BE
JNSW3003 (3M)		
JNSW3005 (5M)		

Option Card

- JNSIF - 232 (RS-232)
- JNSIF - 485 (RS-485)
- JNSIF - MP (Memory pack)
- JNSWPDA (PDA Cable)

JNSWPDA

JNSIF-485

JNSIF-MP

JNSIF-232

Extension Cable

TECO INVERTER

- L510 series : 0.25~1HP(110V)/0.25~3HP(220V)
- E510 series : 0.5~20HP(220V)/1~25HP(440V)
- A510 series : 1~150HP(220V)/1~425HP(440V)
- F510 series : 5~175HP(220V)/5~800HP(440V)



TECO PLC

- TP03 series : 14/20/26/30/36/40/60 I/O MAX256points
- SG2 series : 10/12/20points



Distributor

TECO SERVO

- JSDA+ series : 100W~15kW(220V) /1kW~75kW(440V)
- JSDE+ series : 100W~3kW(220V)



TECO TECO ELECTRIC & MACHINERY CO., LTD.

10F, No.3-1, Yuan Cyu St., Nan-Kang District, Taipei 115, Taiwan TEL:886-2-66159111Ext.1056 FAX:886-2-66151033 GJ-25-14 2013-11-05

<http://globalsa.teco.com.tw>

TECO INVERTER 7300 CV

TECO



TECO INVERTER 7300 CV



Feature

- Sensorless Vector Control
- 150% Starting Torque
- Built-in PLC Function
- LED/LCD Keypad Display
- NPN/PNP Digital Input
- PID Function
- Braking Transistor built-in (Up to 15kw only)
- PC (Windows)/ PDA (WinCE) Link Function
- RS-485 Modbus RTU/ASCII mode
- Field Bus Communication Modules (Option)
 - Profibus-DP
 - DeviceNet
- EMC Filter Built-in (Up to 11kw only)
- Global Standards: UL , cUL , CE
- Copy Unit (Memory pack) Function

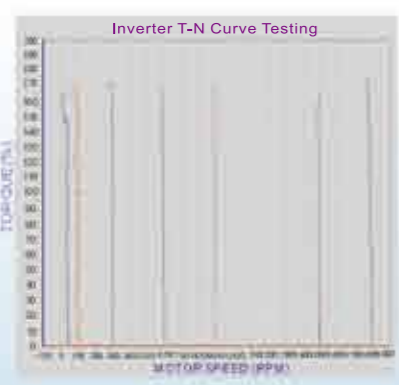
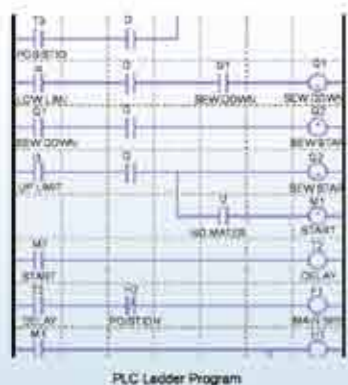

Wiring Diagram

200V 3~40HP example
400V 3~75HP

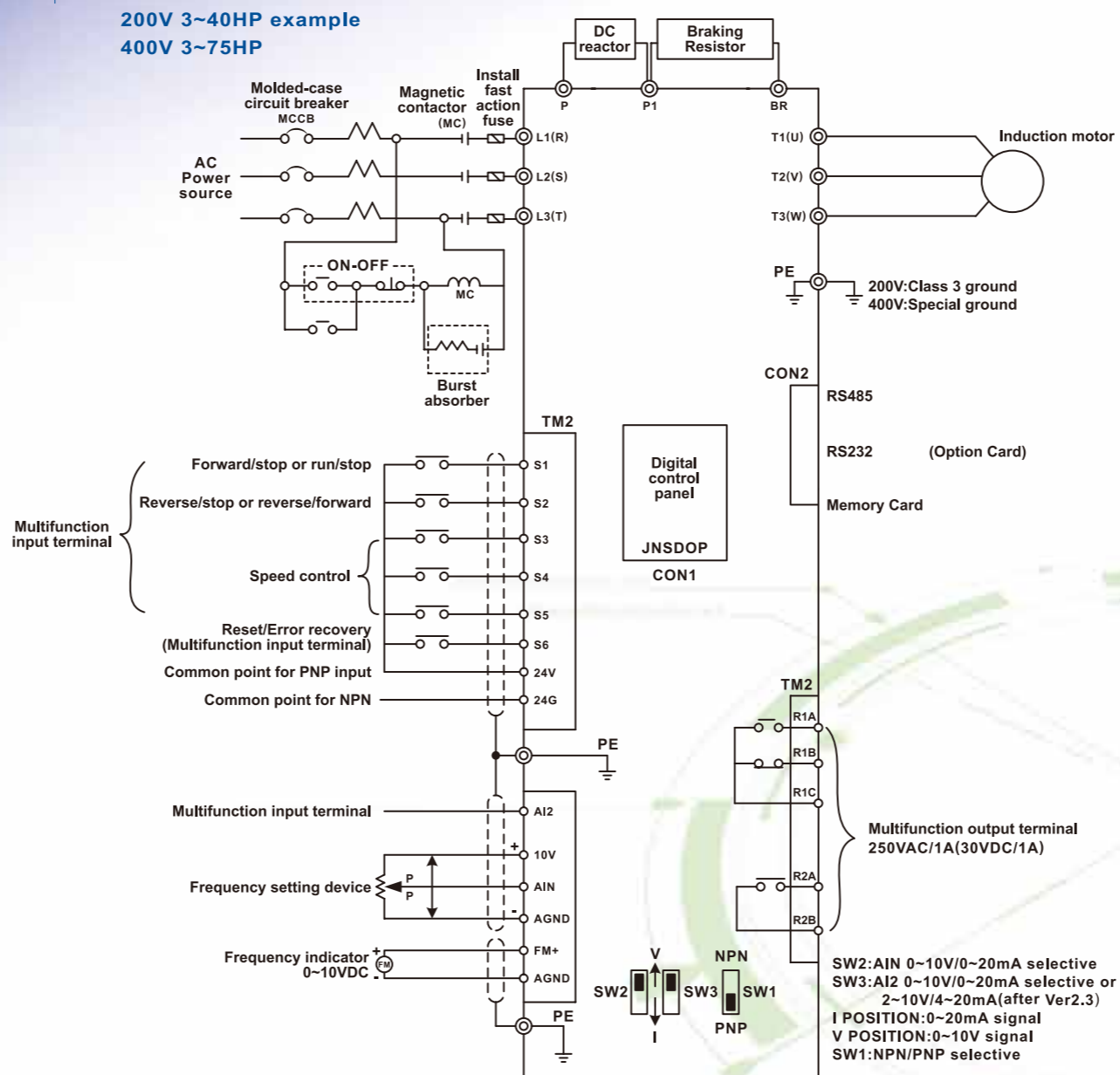

Model Number

JNTH	BC	BA	0001	AC	U	F
7300CV Series	Keypad Panel	Enclosure	Horsepower	Phase of Input Power	UL Approval	Noise Filter
	BC : LED* BG : LCD* BL : Blind*	BA: Open chassis IP20 or IP00 BB: Enclosed Wall mounted type (NEMA1)	R500 : 0.5 HP 0075 : 75 HP	AC: Single phase 220V BC: Three phase 220V BE: Three phase 440V	U: Yes	Blank: None F: Built-in

*BC:LED (Standard) BG:LCD/BL:Blind (Production by order base)
*BB: only for 200V 15~25HP/400V 20~30HP
*BA: NEMA1 kit is available

Specifications

Model	Single phase 200~240V model				Three phases, 200~240V model											
	JNTHBCBA	AC-U(F)	R500	0001	0002	0003	0005	7R50	0010	0015	0020	0025	0030	0040		
Horsepower (HP)	0.5	1	2	3	0.5	1	2	3	5	7.5	10	15	20	25	30	40
Suitable Motor Capacity (KW)	0.4	0.75	1.5	2.2	0.4	0.75	1.5	2.2	3.7	5.5	7.5	11	15	18.5	22	30
Rated Output Current (A)	3.1	4.5	7.5	10.5	3.1	4.5	7.5	10.5	17.5	26	35	48	64	80	96	130
Rated Capacity (KVA)	1.2	1.7	2.9	4.0	1.2	1.7	2.9	4.0	6.7	9.9	13.3	20.6	27.4	34	41	54
Max. Input Voltage	Single Phase: 200~240V +10% -15% , 50/60HZ ± 5%				Three Phases: 200~240V +10% -15% , 50/60HZ ± 5%											
Max. Output Voltage	Three phases: 0~240V				Three phases: 0~240V											
Input Current (A)	8.5	12	16	23.9	4.5	6.5	11	12.5	20.5	33	42	57	70	85	108	138
Net Weight / with Filter (KG)	1.2/1.3	1.2/1.3	1.5/1.8	1.9/2.3	1.2	1.2	1.2	1.75	1.9	5.6	5.6	15	15	15	33	34
Allowable momentary power loss time (second)	1.0	1.0	2.0	2.0	1.0	1.0	2.0	2.0	2.0	2.0	2.0	2.0	2.0	2.0	2.0	2.0
Enclosure	IP20(BA)				IP20(BA)						NEMA1(BB) IP00(BA)					

Model	Three phases 380~480V model															
	JNTHBCBA	BE-U(F)	0001	0002	0003	0005	7R50	0010	0015	0020	0025	0030	0040	0050	0060	0075
Horsepower (HP)	1	2	3	5	7.5	10	15	20	25	30	40	50	60	75	90	110
Suitable Motor Capacity (KW)	0.75	1.5	2.2	3.7	5.5	7.5	11	15	18.5	22	30	37	45	55	66	75
Rated Output Current (A)	2.3	3.8	5.2	8.8	13.0	17.5	25	32	40	48	64	80	96	128	150	180
Rated Capacity (KVA)	1.7	2.9	4.0	6.7	9.9	13.3	19.1	27.4	34	41	54	68	82	110	130	160
Max. Input Voltage	Three phases: 380~480V +10% -15% , 50/60HZ ± 5%															
Max. Output Voltage	Three phases: 0~480V															
Input Current (A)	4.2	5.6	7.3	11.6	17	23	31	38	48	56	75	92	112	142	172	212
Net Weight / with Filter (KG)	1.2/1.3	1.2/1.3	1.8/2.2	1.8/2.2	5.6/6.6	5.6/6.6	15	15	15	33	33	50	50	50	50	50
Allowable momentary power loss time (second)	1.0	1.0	2.0	2.0	2.0	2.0	2.0	2.0	2.0	2.0	2.0	2.0	2.0	2.0	2.0	2.0
Enclosure	IP20(BA)								NEMA1(BB)				IP00(BA)			

ITEM	7300CV TYPE
Control mode	V/F or Sensorless Vector Control
Range	0.1~400.0Hz
Start control torque	150% / 1Hz (Vector mode)
Speed control range	1:50 (Vector mode)
Speed control precision	±0.5% (Vector mode)
Setting resolution	Digital: 0.01Hz (Note *1); Analog: 0.06Hz/60Hz (10bits)
Display function	Set directly with ▲▼ key or the VR on the keypad Four digital LED (or 2x16 LCD) and status indicator; display frequency/ speed/ line speed/ DC voltage/ Output voltage/ Current/ Rotation direction/ Inverter parameter/ Trouble Log/ Program Version
External signal setting	1. External variable resistor / 0-5V / 0-10V / 4-20mA / 5-0V / 10-0V / 20-4mA 2. Performs up/down controls, speed control or automatic procedure control with multifunctional contacts on the terminal block (TM2)
Frequency limit function	Respectively setting upper/lower frequency limits and three-stage prohibited frequencies
Carrier frequency	2~16kHz
V/F pattern	18 fixed patterns, 1 programmable pattern
Acc/Dec control	Two-stage Acc/Dec time (0.1~3,600 seconds) and two-stage S curve
Multifunctional analog output	6 functions (refer to description on 8-00/8-01)
Multifunctional input	30 functions (refer to description on 5-00/5-06)
Multifunctional output	16 functions (refer to description on 8-02/8-03)
Digital input signal	NPN/PNP toggle
Other function	Momentary Power Loss Restart, Speed Search, Overload Detection, 8 Preset Speeds, Acc/Dec Switch (2 Stages), S Curve, 3-wire Control, PID Control, Torque Boost, Slip Compensation, Frequency Upper/ Lower Limit, Auto Energy Saving, Modbus Slave and PC/PDA Link, Auto Restart, Built-in PLC Function.
Communication control	1. Control by RS232 or RS485 2. One-to-one or One-to-many (RS485 ONLY) control. 3. BAUD RATE/STOP BIT/PARITY/bit can be set
Braking torque	About 20%, the model built-in braking transistor and connected braking resistor is 100%
Operation temperature	-10~50°C (note *2)
Storage temperature	-20~60°C
Humidity	0~95% Relative Humidity (Non-condense)
Vibration	1G (9.8m/s ²)
EMC	Comply with requirement EN 61800-3
LVD	Comply with requirement EN 50178
Enclosure	IP00 or IP 20 (Nema 1 by external box attached)
Safety level	UL 508C
Overload protection	The relays to protect the motor (the curve can be set) and the inverter(150% / 1min)
FUSE protection	The motor stops after FUSE melt
Over voltage	200V class: DC Voltage > 410V 400V class: DC Voltage > 820V
Under voltage	200V class: DC Voltage < 190V 400V class: DC Voltage < 380V
Momentary power loss terminal	Stop for more than 15ms-power-loss can be restarted with Speed Search after momentary power loss in Max. 2 sec
Stall prevention	Stall prevention for Acceleration / Deceleration / Operation
Short-circuit output terminal	Electronic Circuit Protection
Grounding fault	Electronic Circuit Protection
Other function	Protection for overheating of heat sink, over torque detection, error contact control, reverse restriction, restrictions for direct start after power up and error recovery, parameter lock up.

Note 1: The setting resolution of above 100Hz is 0.1Hz when controlled with operation keypad, and 0.01 Hz when controlled using computer (PC) or programmable controller (PLC).
Note 2: -10~50°C in distributor (without dustproof cover / pasteur), -10°C~40°C outside distributor (with dustproof cover / pasteur).

