

TECO

MAX - E3 - H66



High Efficiency

Low Voltage 3-Phase Induction Motors | Range 0.75kW to 450kW

TOTALLY ENCLOSED FAN-COOLED CAST IRON FRAME SERIES



Contents

page

page

PRODUCT DETAILS

General Information	2
Electrical Design and Standards	
Altitude	2
Ambient	2
Direction of Rotation	2
Duty Rating	2
Electric Supply	2
Motor Types / MEPS	2
Performance	3
Standards	3
Stator and Windings	3
Testing	3
Variable Speed Drive Suitability	3
Winding Protection	3
Mechanical Design and Standards	
Balance	4
Bearing and Lubrication System	4
Bearing Lubrication Instructions	5
Bearing False Brinelling Protection	5
Cooling System	6
Finish	6
Hardware	6
MAX-E3™ – Mining Spec Motors	6
Mounting	6
Motor Construction	6
Protection	6
Rating Plate	6
Rotor Assembly	7
Terminal Box	7
Maximum Cable Sizes	7
Options	7
Performance Data – High Efficiency MAX-E3-H66 Range 80 ~ 315M	8 ~ 9
Performance Data – High Efficiency AFJE Range 315A ~ 355	10
Outline Dimensions – Frame 80 ~ 132 Foot Mount	11
Outline Dimensions – Frame 160 ~ 250 Foot Mount	12
Outline Dimensions – Frame 280 ~ 315M Foot Mount	13
Outline Dimensions – Frame 315A ~ 355 Foot Mount	14
Outline Dimensions – Frame 80 ~ 132 Flange Mount	15
Outline Dimensions – Frame 160 ~ 250 Flange Mount	16
Outline Dimensions – Frame 80 ~ 200 Foot and Flange Mount	17
Outline Dimensions – Frame 225 ~ 315M Foot and Flange Mount	18
Outline Dimensions – Frame 80 ~ 132 Foot and C Face Mount	19

TECHNICAL DETAILS

Mechanical Design	
Axial / Radial loadings	20
Cooling	21
Force Cooling IC416	22
Mounting (IM code)	23
Mounting - Cast Iron Slide Rails (dimensions)	23
Protection (IP code)	24
Electrical Design	
Altitude and Ambient Temperature	25
Anti-condensation Heaters (optional)	26
Connection Diagrams	26
Duty	26
Efficiency	27
Formulae and Conversion	28
Insulation Classes	29
Speed vs. Torque – Current	29
Starts per Hour	30
Maximum Load Inertia	30
Thermal Protection	31
Thermistors	31
Resistance Temperature Detectors	32
Tolerances for electromechanical characteristics	33
Variable Speed Drives (VVVF)	34 ~ 35
Voltage and Frequency during operation	36



Welcome to Teco!



TECO Australia – Electric Motor Division

Established in 1983 as a wholly owned subsidiary of TECO Electric & Machinery Co., TECO Australia has earned a reputation as a reliable supplier of superior quality Electric Motors, Variable Speed Drive systems and Motor Controls. These products are all designed, manufactured and tested to meet stringent Australian and International Standards.

TECO Electric Motors are regarded as one of the leading brands available on the market and are regularly specified and preferred amongst equipment manufacturers, constructors, engineering companies and major end-users alike.

TECO Electric & Machinery Co.

From modest beginnings in 1956, TECO Electric & Machinery Co. has grown to be one of the worlds largest manufacturers of an extensive range of electric motors. In addition to the core manufacturing facilities in Taiwan, the continual growth of TECO on a global front has seen the formation in 1995 of the TECO Westinghouse Motor Company in the USA, borne out of the 100% ownership of the Westinghouse Motor Company

along with the establishment of additional major manufacturing facilities around the world to service new markets and meet global demand.

TECO Westinghouse

Today TECO designs and manufactures a complete range of low, medium and high voltage motors, Variable Speed Drives and Control Gear with sales and support being offered on a global basis.

Quality Assurance

All TECO manufacturing plants and TECO Australia have been assessed to meet the requirements of ISO9001:2008 documented quality systems.



Environmental and RoHS

TECO major manufacturing plants in Taiwan have ISO14001 Environmental Management System accreditation.

Low Voltage motors manufactured by TECO do not contain (or contain within the maximum allowable limits) any restricted hazardous substances as per European Directive 2002/95/EC(RoHS).



[Driving & Connecting Globally](#)



The new **MAX-E3-H66** range of High Efficiency motors have been specifically designed, manufactured and tested by TECO to meet the most arduous conditions encountered in the Australian mining, heavy industry and other demanding environments.

Motors are protected to IP66 enclosure ratings for harsh Australian conditions and are insulated to Class H (180°C) providing extensive thermal reserve for adverse supply, high ambient conditions or overload situations.

TECO's already proven mechanical and electrical designs, together with these new features will ensure a long and economical life, year after year.

General Information

The motors described in this catalogue are designed and manufactured by TECO Electric & Machinery Co. and are Squirrel Cage Induction Motors intended for general purpose industrial / arduous mining applications and meet all relevant sections of the Australian, New Zealand and International Standards detailed herein.

Electrical Design and Standards

Altitude

Designed for operation at an altitude up to 1000 metres above sea level, refer to [page 25](#) for higher altitudes.

Ambient

Motors are designed to operate in ambient conditions of -20°C to +40°C with motors being capable for operation within an ambient of 50°C. Please refer to [page 24](#) for operation in adverse ambient conditions.

Direction of Rotation

Standard rotation is clockwise when viewed from the drive end with the terminal marking corresponding to incoming line markings.

Duty Rating

All motors have a maximum continuous duty rating of S1 to AS60034-1. Other duty ratings are [available on request](#).

Electric Supply

Stock motors are designed for operation on a 380-415 Volt 3-Phase 50 Hz supply and are also suitable for a 440-480 Volt 3-Phase 60 Hz supply.

Motors 4 kW and below are 380-415 Volt 50 Hz STAR connected and may also be reconnected to 240 Volt 3-Phase 50 Hz DELTA configuration for use with single phase input inverters.

Motors 5.5 kW and larger are 380-415 Volt 50 Hz DELTA connected.

Please refer to [page 26](#) for Connection diagram.

Motors can be manufactured for supply systems of up to 1100 Volts, 50 or 60 Hz on a factory made to order basis or by local rewind / wind.

Motor Types / MEPS (Minimum Efficiency Performance Standard)

All motors meet or exceed the requirements of Australian New Zealand Standard "AS/NZS1359.5-2004 3-Phase cage induction motors - High efficiency performance standards requirements" within the range of 0.75 kW to less than 185 kW, 2 - 4 - 6 & 8 pole single speed, rated S1 continuous duty.

Standards and TECO compliance is detailed below

TECO Type Designation	Frame Size	Output kW	Name plated	Efficiency Level
AEMB	D80 ~ D315M	0.75 ~ 185	TECO MAX-E3-H66	MEPS table B3 High Efficiency
AFJE	D315A ~ D560*	110 ~ 450*	TECO MAX-E3-H66	MEPS table B3* High Efficiency

* MEPS covers motors less than 185kW.
 * Larger sizes also available, [refer to TECO for details.](#)

Performance

Motors are designed to meet the performance requirements of Design N as per AS60034-12, normal torque for Direct On Line starting.

Motors are also suitable for other means of starting, depending on load characteristics, [please refer to TECO.](#)

Other performance characteristics can be manufactured to suit any special requirement.

Standards

Motors are designed, manufactured and tested in accordance with AS1359/AS60034-12. Frame sizes comply with AS1359.30 Australian / British allocations.

Motors also meet the requirements of European Directives where applicable and are CE marked.

TECO has a "Declaration of Conformity" and is a registered user of "C-tick" number N121, which covers TECO squirrel cage induction motors.

For other foreign standards i.e. UL, CSA etc., [please refer to TECO.](#)

Stator and Windings

The stator is made up of exceptional high grade, low loss insulated cold rolled electro magnetic silicon steel laminations for maximum efficiency and low core losses.

Windings are random wound with double enamelled Class H copper wire, impregnated with a solventless resin and are tropic proof rated as standard. Other insulation materials used meet Class H as a minimum.

Windings are designed with a temperature rise

of less than Class B (80°C), however, in most cases are less than Class E (75°C) for long motor life, providing massive thermal reserve for abnormal conditions.

Testing

In addition to a full program of tests during manufacture each motor is subjected to routine tests to AS60034-1 prior to despatch. Performance testing (witnessed or unwitnessed) can be arranged for factory made to order motors.

Variable Speed Drive (VSD) Suitability

Motors are suitable for VSD operation, subject to torque and speed limitations depending on the load characteristics and correct installation of motor and drive.

For Variable torque loads (centrifugal pumps and fans) for speeds between 5~50 Hz derating is not normally required, outside of this range [please check with TECO](#) for motor suitability. Force cooling units are also available when necessary (please refer to [page 22](#) for force cooling details and [page 34-35](#) for VSD rating).

Electro-discharge machining of motor bearings can be a concern in some applications with larger motors on VSD's (please refer to [page 35](#) for our preventative measures).

Winding Protection

Motors frame size D160 and larger are fitted with PTC thermistor protection (P160) within the windings (one per phase) with the leads terminated in the main terminal box.

MAX-E3-H66 HX motors 150 kW and larger have an additional set of PTC thermistors (P150, alarm) within the windings (one per phase) with the thermistor leads terminated in an auxiliary terminal box thereby providing both alarm and trip set of thermistors.

Mechanical Design and Standards

Balance

All rotors are dynamically balanced with a half key to Class N or better, in accordance with AS1359.114.

Bearing and Lubrication System

Frame Size	Poles	DE Bearing	NDE bearing	Greasing/ Shaft Seal
D63 ~ D90L	2	Ball	Ball	Greased for life/ Gamma***
D100L ~ D160L	2	Ball	Ball	Greased for life (GR)/ Gamma***
D180M ~ D250M	2	Ball	Ball	Grease relief
D280S ~ D355*	2	Ball	Ball	Grease relief brass dust flinger
D63 ~ D90L	4 and Above	Ball	Ball	Greased for life/ Gamma***
D100L ~ D132M	4 and Above	Ball	Ball	Greased for life (GR)/ Gamma***
D160M ~ D180M/L	4 and Above	Ball (Roller)	Ball	Greased for life (GR) / Gamma***
D200L ~ D225M	4 and Above	Ball (Roller)	Ball	Grease relief/ Gamma
D250S ~ D250M	4 and Above	Roller (Ball)	Ball	Greased relief/ Gamma
D280S ~ D315M	4 and Above	Roller (Ball)	Ball	Grease relief/ brass dust flinger
D315A ~ D355*	4 and Above	Ball**(Roller)	Ball	Grease relief/ brass dust flinger

Key: (options in the parentheses are alternatives)

GR – Grease Relief

* Larger sizes also available, [refer to TECO for details.](#)

** Ball bearing fitted for direct drive applications, Roller can be fitted for Belt Drive applications, [please refer to TECO.](#)

MaxE mining have a roller at drive end as standard.

*** Oil Seal fitted to flange/Cface.

- 2 Pole motors up to D180 are suitable for direct drive or belt drive.
- 2 Pole motors D200 and larger are suitable for direct drive, belt drive above D200 [please refer to TECO.](#)
- 4 Pole and larger; up to and including D315MC, motor are suitable for Belt or Direct Drive.
- Frames D315A ~ 560 (AFJE) are suitable for direct drive, for Belt Drive refer to TECO “**MAX-E3-H66 HX** motors”. The TECO Through Flush Grease Relief Bearing System gives positive displacement of old grease and is designed for re-greasing during operation.

TECO Through Flush Grease Relief Bearing System with Gamma Seal to D250

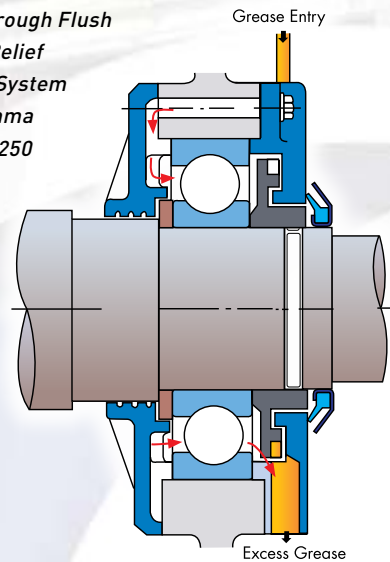

TECO Through Flush Grease Relief Bearing System with Brass Dust Flinger D280-355

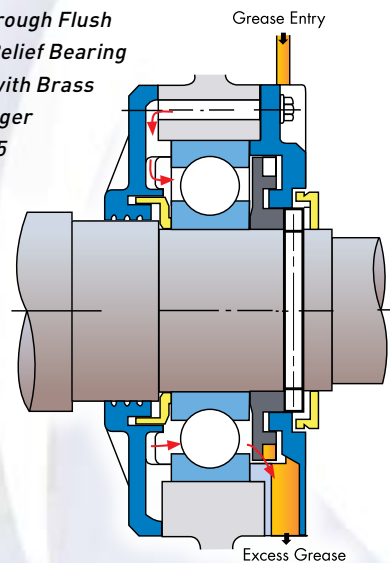

The fitment of rotating inner & outer labyrinth seals achieves effective sealing from ingress of contamination.

This is a true pressure grease relief system where the grease enters the back of the bearing then is forced through to the front and is expelled through a large external discharge chute.

This system will not allow over greasing to affect the performance of the bearings. This type of grease replenishment system will not allow contaminants to be pushed back into the bearing itself, which can cause premature bearing failure.

Bearing Lubrication Instructions

Table 1: Bearing Grease Schedule - 50Hz Operation

Bearing Number	8 Pole	6 Pole	4 Pole	2 Pole
62XX 6210	3000Hrs			2000Hrs
63XX 12				
72XX 13				
73XX 14				
15				
16				
17				
18				
20				
22				
24				
26				

Bearing Number	8 Pole	6 Pole	4 Pole		
NU2XX NU214	3000Hrs		2000Hrs		
NU3XX 15					
16					
17					
18					
20					
22					
24					
26				2000Hrs	500Hrs

Table 2: Bearing Grease Fill

Bearing Number	Amount (grams)	Bearing Number	Amount (grams)
62XX 6210	30	63XX 6310	40
72XX 12	40	73XX 12	60
NU2XX 13	50	NU3XX 13	80
14	50	14	80
15	60	15	100
16	60	16	100
17	80	17	120
18	80	18	120
20	100	20	160
22	120	22	220
24	120	24	270
		26	300

- Notes:**
1. Please ensure bearings are fully purged during commissioning, thereafter adhere to the above greasing schedule.
 2. Replenishment of grease recommended when motor is running.
 3. Do not mix dissimilar greases.
 4. TECO recommends use of SHELL GADUS S2 V100 Lithium based grease on motors frame size up to and including D315M.

When do motors require greasing?

At initial start during commissioning.
 If the motor has been out of service for three (3) months or longer.
 At predetermined intervals, please refer to "Table 1".

What to do prior to greasing?

Check the motor nameplate for the type of grease and check that the grease you plan to use is fully compatible.
 Clean the grease nipples on the motor and the grease gun discharge connection.
 Ensure that the grease discharge chute on the motor is clean and not blocked with old hard grease.

How to effectively grease an electric motor?

The electric motor must be running with preferably the bearings up to normal operating temperature.
 Pump-in ½ of the required quantity of grease as in "Table 2" to each bearing and allow to settle.
 After 5-10 minutes pump-in the other ½ of the required grease quantity.
 Please note it is normal to see an increase in the bearing temperature during the greasing procedure.
 Expelled grease should be evident at the rotating labyrinth seal and within the discharge chute.
 30 minutes after the greasing procedure the bearing temperatures should return to normal, if not, please check that there are no other reasons for an increase in bearing temperature, i.e. misalignment, high vibration etc.

Bearing False Brinelling Protection

A bearing, will experience false brinelling when it is not turning and subjected to vibrations of some sort. This is generally in cylindrical roller type bought about from transportation without an effective shaft lock to prevent movement or from vibration of the motor when de-energized. Because the bearing is not turning, the grease or oil will be gradually removed from the ball or roller contacts ending in metal to metal contact. Wear is then allowed to take place and the damage will cause the bearing to fail prematurely after start up. TECO do fit a shaft locks on D180 2 pole ~ D200 4 pole and larger to prevent false brinelling.

Extensive shaft locking clamp on large AFJE motor



Cooling System

Cooling is Totally Enclosed Fan Cooled (TEFC), with integrally cast cooling fins on frame and endshields, fitted with external fan (IC411) to AS60034-7.

The cooling fans are bi-directional and low noise as standard (2 pole 220 kW and larger have uni-directional fans only).

Finish

All external components are shot blast to a near white finish. A durable coat of Alkyd Resin primer giving excellent corrosion protection follows this preparation. The complete motor is then finish coated with Alkyd Resin Gloss Enamel in TECO Westinghouse Blue (Munsell 5PB3/8).

Other paint systems and colours are available upon request, including chemical duty two pack epoxy paint systems.

Hardware

All hardware is electro zinc plated for better corrosion resistance.

Stainless steel hardware can be offered as an alternative, [please contact TECO](#) for the surcharge to provide this feature.

MAX-E3-H66 HX Motors

Arduous Mining Crusher Duty

Frames D315MC to D355

These are a special range of motors, which meet the High Efficiency MEPS level and also have the following extra features as standard:

- Oversized drive end shaft and bearings for demanding belt drive applications.
- Two sets of thermistors providing an alarm and trip set with auxiliary terminal box.
- Oversized Fabricated Steel primary terminal box with non ferrous blank gland plate.

Mounting

Motors are available in the following mountings, refer to [page 23](#) for IM codes of mountings.

- Foot mounted
- Foot and Flange mounted
- Flange mounted
- Foot and C Face mounted
- C Face mounted

Motor Construction

Motor frames are high grade Cast Iron with integrally cast feet and cast iron end shields, suiting mining applications.

Castings are machined to close tolerances in order to ensure accurate alignment with minimum vibration.

Standard Materials of Construction

Frame Size	External Fan	Fan Cover	Terminal Box
D80 ~ D132	CPP (CI)	HDPS (CI)	CI
D160 ~ D315M	CI	HDPS (CI)	CI
D315A ~ D355*	FS	FS	FS* (CI)

Key: (material in parentheses is alternative)
 CPP – Conductive Polypropylene (Non Sparking)
 CI - Cast Iron
 HDPS - Heavy Duty Pressed Steel
 FS - Fabricated Steel
 FS* - Fabricated Steel with blank cable entry gland plate.
 * Larger sizes are also available, [please refer to TECO](#) for details.

Protection (IP rating – stock motors)

All motors are rated IP66, thereby providing excellent protection against the ingress of dust and water.

Rating Plate

A stainless steel rating plate containing all details as specified in AS60034-1 including bearing sizes are fitted to all motors. Rating plate also confirms compliance with MEPS Efficiency Standard and is **“MAX-E3-H66 High Efficiency”** (MEPS table B3). All motors are fitted with a Teco Mining Motor Nameplate.



Rotor Assembly

As per the stator, the rotor core is made up of exceptional high grade, low loss insulated cold rolled electro magnetic steel laminations for maximum efficiency and low core losses.

The rotor cage is pressure die cast high conductivity aluminium with waffer blades and balance supports integrally cast onto the rotor endrings.

On some larger AFJE motors, the rotor is of copper/copper alloy rotor bar construction. This rotor construction offers superior performance and reliability. TECO utilizes high frequency induction brazing as a means to enhance the structural integrity of the rotor bar to endring joint. Induction brazing provides an "all at once" uniform braze that reduces stresses and hot spots in the joint, which can cause premature fatigue and rotor bar failure.

The rotor is a press fit onto the high tensile steel shaft (ANSI1040) and is also keyed onto the shaft on motor frames D200 and larger.

Induction Brazing



Finished Rotor and Shaft Assemblies



Terminal Box

On motors up to and including D315M, the terminal box is mounted on the right hand side viewed from drive end and can be transferred to the left hand side upon request.

For frames D315A (AFJE) and larger the terminal box is at the 2 o'clock position on the right hand side (alternative terminal box locations are [available on request, please refer to TECO](#)).

All terminal boxes have one-piece neoprene gaskets between frame, box and gland plate and can be rotated through 360° in 90° increments. An internal earth is provided within the motor terminal box.

Maximum Cable Sizes

Frame Size	Maximum Cable Size
D80 ~ D112	10 mm ²
D132 ~ D180	50 mm ²
D200 ~ D225	95 mm ²
D250 ~ D315M*	185 mm ²

Notes: Sizes based on -
 3 core + Earth Copper PVC Insulated / PVC Sheathed or
 3 core + Earth Copper PVC Insulated / Steel Wire Armoured.
 Standard Cast Iron terminal box *
 Larger terminal boxes available, [please refer to TECO](#).

Options

Some available options in this range are as follows:

- Airstream rated IC418
- Anti-condensation heaters
- Auxiliary terminal boxes for Thermistor / Heater / RTD terminations
- Electromechanical "fail safe" Brake Motors
- Cooling Tower application
- Crane rated motors
- Double / non standard shaft extensions
- Encoder / Tacho
- Force ventilation IC416
- Induction Generators
- Insulated bearing
- IP66 enclosure
- Multi-speed motors
- Resistance temperature detectors (RTDs) winding and / or bearings
- Rotor Groundary brush
- Smoke spill to BS7436 to 185 kW
- Special paint systems / colours
- Stainless steel fasteners
- Thermistor protection (on motor frames <D160)
- Others on request

Typical Performance Data MAX-E3-H66

TECO Cast Iron TEFC 3-Phase Squirrel Cage Induction Motors

AEMB High Efficiency Range MAX-E3-H66 80 to 315M Frame (415V 50Hz)

Output kW	Full Load Rpm	Frame No.	Efficiency			Power Factor			Current		Torque				Inertia		dBA	Weight Foot Mount Kgs (approx)
			Full Load (%)	3/4 Load (%)	1/2 Load (%)	Full Load (%)	3/4 Load (%)	1/2 Load (%)	Full Load (A)	Locked Rotor (%)	Full Load N-m	Locked Rotor %FLT	Pull Up %FLT	Break-Down %FLT	ROTOR J = GD ² /4 Kg-m ²	MAX J = GD ² /4 Kg-m ²		
0.75	2825	80	83.0	82.0	79.0	85.0	79.0	65.0	1.48	878	2.53	280	250	350	0.002	0.081	57	20
	1440	80	84.5	82.0	79.0	74.5	65.0	50.5	1.66	783	4.97	295	260	375	0.003	0.353	44	20
	935	90S	80.5	80.0	78.5	73.0	64.5	51.5	1.78	562	7.64	200	155	235	0.006	0.913	46	24
	700	100L	76.6	76.5	73.0	60.0	50.5	38.5	2.27	441	10.2	235	220	230	0.011	1.89	49	39
1.1	2815	80	84.5	84.0	82.0	85.0	79.0	66.0	2.13	845	3.72	300	260	330	0.002	0.110	53	20
	1435	90S	86.0	86.5	85.5	80.5	73.5	60.5	2.21	814	7.31	255	180	290	0.005	0.523	46	24
	935	90L	82.5	81.5	79.5	73.0	65.0	52.0	2.54	591	11.2	200	175	240	0.007	1.40	46	29
	695	100L	79.5	80.0	77.5	64.0	55.0	42.5	3.01	498	15.1	210	200	215	0.015	2.74	49	39
1.5	2895	90S	86.5	87.0	85.0	85.0	79.0	66.5	2.84	880	4.94	300	265	375	0.003	0.145	56	24
	1440	90L	87.0	86.0	84.0	76.0	67.0	53.0	3.16	791	9.94	285	215	340	0.006	0.670	47	29
	950	100L	84.0	84.0	81.5	73.0	67.0	54.0	3.40	735	15.1	235	225	280	0.015	1.83	45	39
	705	112M	82.1	81.0	78.5	66.5	58.0	45.0	3.82	523	20.3	170	155	235	0.023	3.65	49	50
2.2	2900	90L	87.5	87.0	85.0	80.0	72.0	58.0	4.37	892	7.23	340	295	405	0.004	0.213	55	29
	1455	100L	88.5	88.0	86.0	81.0	73.0	59.0	4.27	913	14.4	275	195	355	0.012	1.04	49	39
	965	112M	87.2	85.5	85.0	67.0	54.0	47.5	5.24	668	21.7	200	180	285	0.021	2.68	51	50
	705	132S	84.6	83.5	82.0	69.0	60.0	46.5	5.24	572	29.8	230	205	265	0.035	5.29	49	75
3	2870	100L	88.5	88.5	87.0	88.0	85.0	76.0	5.36	932	9.97	355	330	375	0.006	0.280	57	39
	1450	100L	89.5	87.5	85.5	78.0	69.0	54.5	5.98	903	19.7	285	200	360	0.013	1.34	49	39
	970	132S	88.8	87.5	86.0	78.0	71.0	59.0	6.03	746	29.5	200	180	295	0.039	3.50	51	75
	715	132M	85.3	85.0	83.0	64.0	54.5	41.0	7.65	588	40.0	280	260	330	0.045	6.97	50	82
4	2885	112M	90.3	90.5	90.0	90.0	87.0	80.0	6.85	949	13.2	315	300	350	0.012	0.383	57	50
	1450	112M	90.0	89.5	89.0	82.0	76.0	63.5	7.54	862	26.3	275	155	330	0.021	1.81	50	50
	970	132M	89.6	89.0	87.0	78.0	71.5	59.0	7.96	754	39.3	210	195	310	0.052	4.75	51	82
	720	160M	87.1	86.0	84.5	70.5	62.0	48.5	9.06	607	53.0	190	170	250	0.086	9.51	51	133
5.5	2930	132S	91.7	91.5	90.5	85.0	82.0	73.0	9.82	866	17.9	220	190	300	0.019	0.505	64	75
	1460	132S	91.0	90.5	90.5	85.5	81.0	72.0	9.83	916	35.9	250	205	320	0.033	2.37	55	75
	970	132M	89.5	89.5	88.5	74.5	66.5	54.0	11.5	826	54.1	245	215	335	0.054	6.33	53	82
	720	160M	88.0	87.0	85.0	71.5	63.0	50.0	12.2	615	72.8	200	185	275	0.126	12.7	54	133
7.5	2920	132S	91.7	91.0	91.5	85.0	79.0	70.0	13.4	821	24.5	210	175	275	0.021	0.670	64	75
	1465	132M	91.7	92.0	91.5	85.0	80.5	71.0	13.4	896	48.8	255	195	345	0.043	3.10	55	82
	970	160M	91.0	90.5	89.5	79.0	73.0	61.5	14.5	690	73.7	270	235	270	0.121	8.34	55	133
	720	160L	89.0	88.0	86.0	71.0	64.5	51.0	16.5	606	99.4	225	215	295	0.168	16.6	55	158
11	2945	160M	93.2	92.5	92.0	91.0	89.0	83.5	18.0	777	35.6	230	185	285	0.046	0.973	70	133
	1465	160M	92.9	92.5	92.0	86.0	82.5	73.5	19.2	729	71.6	235	190	275	0.092	4.57	56	133
	965	160L	91.5	91.0	90.5	80.0	74.5	63.0	20.9	766	109	285	255	295	0.158	12.2	59	158
	720	180L	90.5	90.5	90.0	72.0	61.0	52.5	20.6	606	146	170	150	210	0.320	24.3	56	210
15	2935	160M	93.5	92.0	91.5	90.0	87.0	80.0	24.8	786	48.7	240	215	310	0.051	1.28	70	133
	1465	160L	93.0	93.0	92.5	86.0	83.0	74.5	26.1	747	97.6	245	195	285	0.116	6.02	56	158
	970	180LC	92.0	92.0	92.0	84.0	81.0	72.5	27.0	630	147	230	165	250	0.336	15.9	58	205
	730	200LC	91.7	90.5	89.0	78.0	72.0	60.0	29.2	616	196	195	170	230	0.521	31.8	57	282
18.5	2940	160L	93.8	93.5	93.0	90.5	87.0	79.5	30.3	809	60.0	260	225	300	0.059	1.55	72	158
	1480	180M	94.0	94.0	93.0	83.0	76.0	64.5	33.0	742	119	200	140	250	0.177	7.42	63	190
	975	200LC	93.0	93.0	92.5	82.0	78.5	69.5	33.7	653	181	230	165	245	0.459	19.7	55	295
	735	225SC	93.6	93.0	92.5	77.0	71.5	60.0	35.7	532	240	195	125	195	0.727	39.3	58	360

- Notes:**
- All figures are based on tests carried out on 415 Volt 3 Phase Motors.
 - Test Method: AS/NZS1359.5 Method B
 - Tolerance: Refer to [page 33](#).
 - dB(A): Mean Sound Pressure Level on no load and 1 metre.
 - Motor data 8 pole and slower speeds not listed [available on request](#).
 - Data subject to change without notice.

Typical Performance Data **MAX-E3-H66**

TECO Cast Iron TEFC 3-Phase Squirrel Cage Induction Motors

AEMB High Efficiency Range **MAX-E3-H66** 80 to 315M Frame (415V 50Hz)

Output kW	Full Load Rpm	Frame No.	Efficiency			Power Factor			Current		Torque				Inertia		dBA	Weight Foot Mount Kgs (approx)
			Full Load (%)	3/4 Load (%)	1/2 Load (%)	Full Load (%)	3/4 Load (%)	1/2 Load (%)	Full Load (A)	Locked Rotor (%)	Full Load N-m	Locked Rotor %FLT	Pull Up %FLT	Break-Down %FLT	ROTOR J = GD ² /4 Kg-m ²	MAX J = GD ² /4 Kg-m ²		
22	2950	180MA	94.1	94.0	93.0	87.0	85.0	77.0	37.4	882	71.1	225	180	275	0.0708	1.89	72	190
	1480	180LC	94.5	94.0	93.5	83.0	76.5	65.0	39.0	692	142	200	140	240	0.1980	8.76	64	205
	975	200LC	93.5	93.5	93.5	82.5	79.5	71.0	39.7	655	215	220	180	240	0.5213	23.4	54	295
	740	225MC	93.7	93.0	92.0	73.0	66.0	54.0	44.7	515	284	225	145	230	0.8140	46.8	58	375
30	2945	200LA	94.5	94.0	93.0	90.5	91.0	88.5	48.8	717	97.1	170	120	250	0.1505	2.43	76	300
	1475	200LC	94.5	94.5	94.5	86.0	84.5	77.0	51.4	798	194	265	215	285	0.3628	11.5	64	295
	985	225MC	94.6	94.0	93.5	83.0	79.5	70.0	53.1	574	290	210	170	230	0.7558	30.5	61	388
	735	250SC	93.5	93.0	92.0	74.5	68.0	56.0	59.9	701	389	260	225	295	1.2345	61.3	65	510
37	2960	200LA	94.9	94.5	93.5	91.0	90.5	87.0	59.6	780	119	195	140	275	0.1883	2.98	76	300
	1480	225SC	95.4	95.0	94.5	85.0	82.0	74.0	63.5	724	239	205	185	290	0.4740	14.1	69	360
	985	250SC	95.1	94.5	94.5	86.0	82.5	74.0	62.9	715	358	245	210	265	1.1400	37.8	64	510
	740	250MC	94.0	93.0	92.0	76.0	70.0	58.5	72.1	680	477	245	215	270	1.4173	75.5	68	570
45	2960	225MA	95.6	95.0	94.0	93.0	92.0	87.0	70.4	736	145	150	120	320	0.2968	3.53	80	377
	1480	225MC	95.4	95.0	95.0	85.5	82.0	74.0	76.7	665	290	200	170	275	0.4948	16.7	69	388
	985	250MC	94.5	94.5	94.0	86.5	84.0	76.0	76.6	764	436	240	205	270	1.2765	44.8	66	570
55	2970	250SA	95.8	94.5	94.0	91.5	90.5	87.0	87.3	739	177	150	130	315	0.3868	4.32	78	480
	1485	250SC	95.8	95.0	95.0	86.0	83.5	76.5	92.8	744	353	220	245	275	0.9778	20.3	71	510
	984	280SC	95.7	95.0	94.3	84.0	81.5	74.0	95.0	684	533	165	140	230	2.1250	55.0	78	750
75	2960	250MA	95.5	95.0	95.0	92.0	91.0	88.0	119	693	242	140	130	295	0.4540	5.60	78	540
	1480	250MC	95.7	95.0	95.0	86.0	84.5	79.0	127	740	484	220	230	250	1.1225	26.8	72	570
	984	280MC	95.8	95.7	95.3	85.0	82.0	75.0	128	684	727	160	136	230	2.7750	46.8	78	850
90	2960	280SA	96.1	95.7	94.8	90.0	88.0	82.0	145	755	290	130	110	230	0.6750	6.88	85	660
	1480	280SC	96.2	95.5	94.9	86.5	83.6	77.0	148	740	580	160	136	230	1.8250	33.0	82	820
	985	315SC	96.4	95.8	95.2	85.5	82.5	76.0	152	720	872	155	131	230	4.2750	88.3	78	980
110	2960	280MA	96.3	95.7	94.7	90.0	88.0	82.0	177	763	355	120	102	230	0.8000	8.08	85	720
	1482	280MC	96.4	96.3	95.9	87.5	84.0	77.5	181	746	709	140	110	230	2.1500	39.0	82	880
	985	315MC	96.5	96.0	95.3	86.0	83.0	76.5	184	734	1068	100	90	220	4.9750	105	78	1070
132	2976	315SA	96.6	95.7	94.9	90.0	88.0	82.0	211	754	423	115	98	220	1.2750	9.13	85	900
	1482	315SB	96.7	95.9	95.3	88.0	84.5	78.5	216	736	850	140	110	220	3.0500	44.0	82	1000
	986	315MC	96.5	96.0	95.4	86.0	83.0	76.5	221	719	1274	100	90	220	5.1750	120	78	1180
150	2976	315MA	96.7	96.1	95.3	90.0	89.0	83.0	240	750	481	105	91	220	1.4500	10.5	85	940
	1485	315MC	96.9	96.0	95.7	88.0	84.5	79.0	245	735	964	100	90	220	3.5500	50.5	82	1080
185	2982	315MA	97.0	96.3	95.6	90.0	89.0	83.0	295	780	592	105	91	220	1.5000	12.8	85	1050
	1486	315MB	97.0	96.0	95.7	88.5	85.0	79.5	300	767	1186	100	90	220	3.6000	61.8	82	1150
	1486	315MC*	97.0	96.0	95.7	88.5	85.0	79.5	300	767	1186	100	90	220	3.6000	61.8	82	1150

- Notes:**
1. All figures are based on tests carried out on 415 Volt 3 Phase Motors.
 2. Test Method: AS/NZS1359.5 Method B
 3. Tolerance: Refer to [page 33](#).
 4. dB(A): Mean Sound Pressure Level on no load and 1 metre.
 5. Motor data 8 pole and slower speeds not listed [available on request](#).
 6. *185kW motor in D315MC frame with fabricated steel terminal box and oversize drive shaft.
 7. Data subject to change without notice.

Typical Performance Data **MAX-E3-H66**

TECO Cast Iron TEFC 3-Phase Squirrel Cage Induction Motors

AFJE High Efficiency Range **MAX-E3-H66** 315A to 355 Frame (415V 50Hz)

Output kW	Full Load RPM	Frame NO.	Efficiency			Power Factor			Current		Torque				Rotor Inertia $J = GD^2/4$ Kg-m ²	Weight Foot Mount Kgs
			Full Load (%)	3/4 Load (%)	1/2 Load (%)	Full Load (%)	3/4 Load (%)	1/2 Load (%)	Full Load (A)	Locked Rotor (%)	Full Load N-m	Locked Rotor %FLT	Pull Up %FLT	Break-Down %FLT		
150	991	315AC	96.2	96.0	95.3	86.1	82.0	72.4	252	696	1441	123	105	225	5.45	1630
185	991	315AC	96.2	96.2	95.6	85.8	81.5	71.8	312	702	1803	130	111	228	6.33	1730
220	1489	315CC	96.7	96.7	96.3	90.6	88.4	81.9	349	753	1441	112	95	244	6.23	1850
220	991	315CC	96.4	96.3	95.8	85.0	80.3	70.5	374	731	2156	139	118	242	7.65	1880
250	1490	315CC	96.8	96.7	96.3	90.3	87.4	79.7	398	767	1607	113	96	266	6.65	1900
260	991	315DC	96.5	96.4	95.9	84.6	80.5	70.3	443	693	2508	140	119	246	9.43	2080
300	1490	315DC	96.9	96.9	96.6	90.4	87.7	80.3	476	795	1911	123	105	259	7.53	2000
375	1490	315DC	97.0	97.0	96.7	90.8	88.7	82.7	592	794	2391	122	102	250	9.70	2250
450	1490	355CC	97.0	97.0	96.7	89.5	88.1	82.7	721	729	2871	111	94	239	11.48	2780

- Notes:**
1. All figures are based on tests carried out on 415 Volt 3 Phase Motors.
 2. Test Method: AS/NZS1359.5 Method B
 3. Tolerance: Refer to [page 33](#).
 4. dB(A): Mean Sound Pressure Level on no load and 1 metre.
 5. Motor data 8 pole and slower speeds not listed [available on request](#).
 6. Data subject to change without notice.

AFJE MAX-E3-H66 Motor
FRAME SIZES D315A-355



Outline Dimensions Sheet **MAX-E3-H66**

TECO Cast Iron TEFC 3-Phase Squirrel Cage Induction Motors

Frame 80 - 132 Foot Mount

Totally Enclosed Fan Cooled Squirrel Cage Rotor

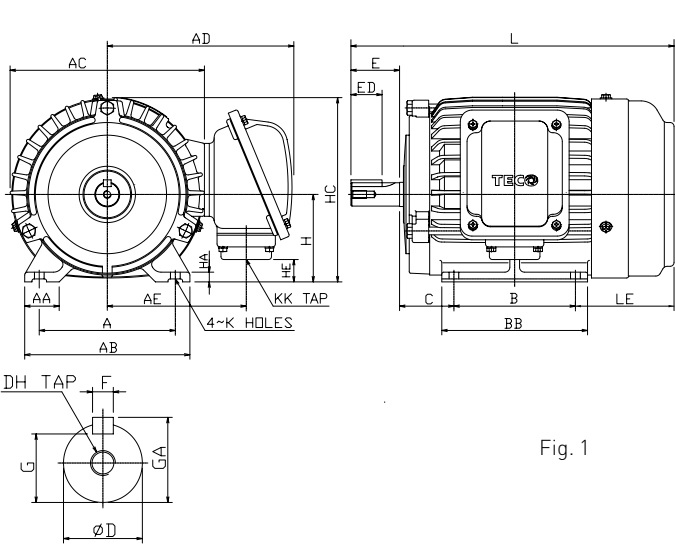

Fig. 1

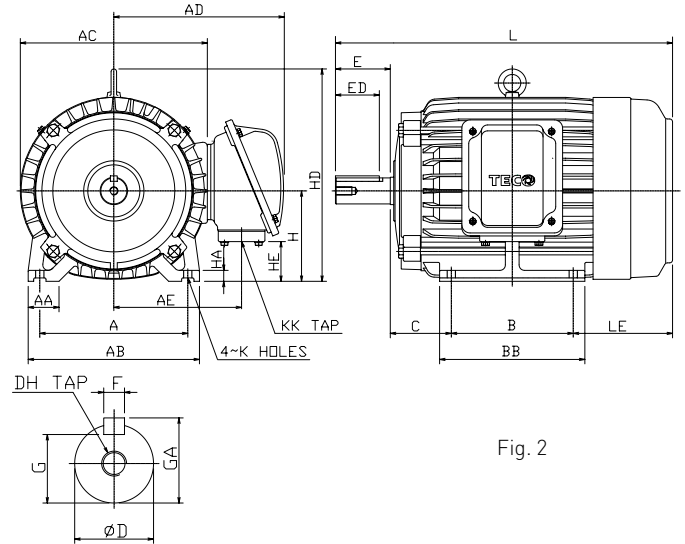

Fig. 2

Output (kW)				Frame Size	Fig. No.	Dimensions (mm)												
2P	4P	6P	8P			A	AA	AB	AC	AD	AE	B	BB	C	H	HA	HC	HD
0.75 / 1.1	0.55 / 0.75	0.37 / 0.55	0.18	80	1	125	35.5	155	177	179	130	100	130	50	80	9	168	-
1.5	1.1	0.75	0.37	90S		140	35.5	170	200	192	143	100	130	56	90	10	190	-
2.2	1.5	1.1	0.55	90L	2	140	35.5	170	200	192	143	125	150	56	90	10	190	-
3	2.2 / 3	1.5	0.75 / 1.1	100L		160	45	195	219	202	153	140	175	63	100	12.5	-	243
4	4	2.2	1.5	112M		190	45	224	238	211	162	140	175	70	112	14	-	265
5.5 / 7.5	5.5	3	2.2	132S		216	45	250	273	249	187	140	175	89	132	16	-	310
-	7.5	4 / 5.5	3	132M		216	45	250	273	249	187	178	212	89	132	16	-	310

Frame Size	Shaft Extension					Bearings								
	HE	K	KK	L	LE	D	E	ED	F	G	GA	DH	DE	NDE
80	13	10	M25 × P1.5	282.5	92.5	19	40	25	6	15.5	21.5	M6 × 12	6204ZZ	6204ZZ
90S	23	10	M25 × P1.5	307.5	101.5	24	50	32	8	20	27	M8 × 16	6205ZZ	6205ZZ
90L	23	10	M25 × P1.5	332.5	101.5	24	50	32	8	20	27	M8 × 16	6205ZZ	6205ZZ
100L	33	12	M25 × P1.5	374.5	111.5	28	60	40	8	24	31	M10 × 20	6206ZZ	6305ZZ
112M	45	12	M25 × P1.5	391.5	121.5	28	60	40	8	24	31	M10 × 20	6306ZZ	6306ZZ
132S	58	12	M40 × P1.5	454	145	38	80	64	10	33	41	M12 × 24	6308ZZ	6306ZZ
132M	58	12	M40 × P1.5	492	145	38	80	64	10	33	41	M12 × 24	6308ZZ	6306ZZ

- Notes:**
1. Tolerance: Refer to [page 33](#).
 2. Data subject to change without notice and should not be used for installation purposes.

**AEMB MAX-E3-H66 Motor
TO FRAME SIZE D250M**



Outline Dimensions Sheet **MAX-E3-H66**

TECO Cast Iron TEFC 3-Phase Squirrel Cage Induction Motors

Frame 160 - 250 Foot Mount

Totally Enclosed Fan Cooled Squirrel Cage Rotor

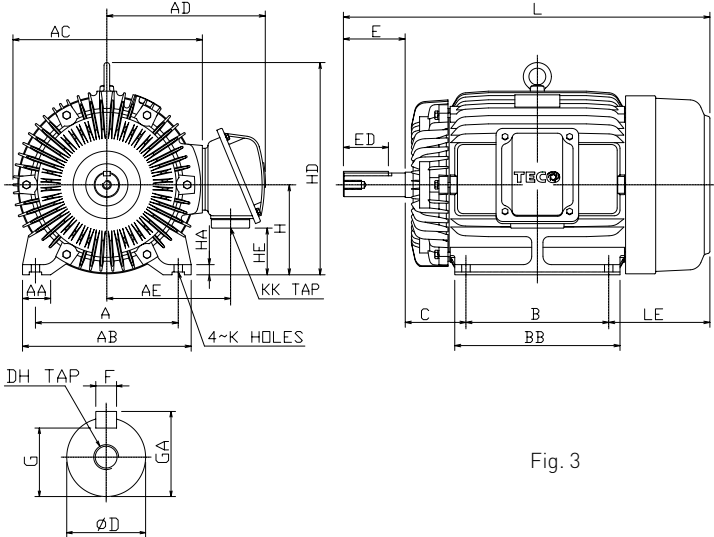

Fig. 3

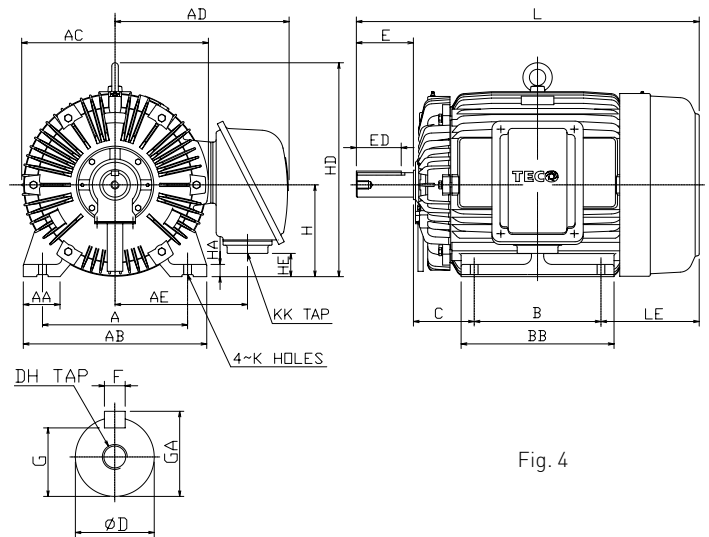

Fig. 4

Output (kW)				Frame Size	Fig. No.	Dimensions (mm)											
2P	4P	6P	8P			A	AA	AB	AC	AD	AE	B	BB	C	H	HA	HD
11 / 15	11	7.5	4 / 5.5	160M	3	254	50	300	334	287	225	210	250	108	160	18	377
18.5	15	11	7.5	160L		254	50	300	334	287	225	254	300	108	160	18	377
22	-	-	-	180MA	4	279	75	355	382	312	250	241	297	121	180	22	431
-	18.5	-	-	180MC	3	279	75	355	382	312	250	241	297	121	180	22	431
-	22	15	11	180LC		279	75	355	382	312	250	279	335	121	180	22	431
30 / 37	-	-	-	200LA	4	318	80	400	420	374	287	305	365	133	200	25	469
-	30	18.5 / 22	15	200LC		318	80	400	420	374	287	305	365	133	200	25	469
-	37	-	18.5	225SC	4	356	90	450	458	427	330	286	350	149	225	30	524
45	-	-	-	225MA		356	90	450	458	427	330	311	375	149	225	30	524
-	45	30	22	225MC	4	356	90	450	458	427	330	311	375	149	225	30	524
55	-	-	-	250SA		406	100	500	510	493	375	311	385	168	250	36	595
-	55	37	30	250SC	4	406	100	500	510	493	375	311	385	168	250	36	595
75	-	-	-	250MA		406	100	500	510	493	375	349	425	168	250	36	595
-	75	45	37	250MC	4	406	100	500	510	493	375	349	425	168	250	36	595
-	-	-	-	250MC		406	100	500	510	493	375	349	425	168	250	36	595

Frame Size						Shaft Extension							Bearings	
	HE	K	KK	L	LE	D	E	ED	F	G	GA	DH	DE	NDE
160M	83	14.5	M40 × P1.5	608	180	42	110	80	12	37	45	M16 × 32	6309ZZ	6307ZZ
160L	83	14.5	M40 × P1.5	652	180	42	110	80	12	37	45	M16 × 32	6309ZZ	6307ZZ
180MA	103	14.5	M40 × P1.5	672	200	48	110	80	14	42.5	51.5	M16 × 32	{6211C3}	{6211C3}
180MC	103	14.5	M40 × P1.5	672	200	48	110	80	14	42.5	51.5	M16 × 32	6311ZZ	6310ZZ
180LC	103	14.5	M40 × P1.5	710	200	48	110	80	14	42.5	51.5	M16 × 32	6311ZZ	6310ZZ
200LA	88	18.5	M50 × P1.5	770	222	55	110	80	16	49	59	M20 × 40	{6312C3}	{6212C3}
200LC	88	18.5	M50 × P1.5	770	222	55	110	80	16	49	59	M20 × 40	6312	6212
225SC	57	18.5	M50 × P1.5	816	241	60	140	110	18	53	64	M20 × 40	6313	6213
225MA	57	18.5	M50 × P1.5	811	241	55	110	80	16	49	59	M20 × 40	{6312C3}	{6212C3}
225MC	57	18.5	M50 × P1.5	841	241	60	140	110	18	53	64	M20 × 40	6313	6213
250SA	42	24	M63 × P1.5	882.5	263.5	60	140	110	18	53	64	M20 × 40	{6313C3}	{6213C3}
250SC	42	24	M63 × P1.5	882.5	263.5	70	140	110	20	62.5	74.5	M20 × 40	NU316	6313
250MA	42	24	M63 × P1.5	920.5	263.5	60	140	110	18	53	64	M20 × 40	{6313C3}	{6213C3}
250MC	42	24	M63 × P1.5	920.5	263.5	70	140	110	20	62.5	74.5	M20 × 40	NU316	6313

Notes: 1. Tolerance: Refer to [page 33](#).
2. Data subject to change without notice and should not be used for installation purposes.

Outline Dimensions Sheet **MAX-E3-H66**

TECO Cast Iron TEFC 3-Phase Squirrel Cage Induction Motors

Frame 280 - 315M Foot Mount

Totally Enclosed Fan Cooled Squirrel Cage Rotor

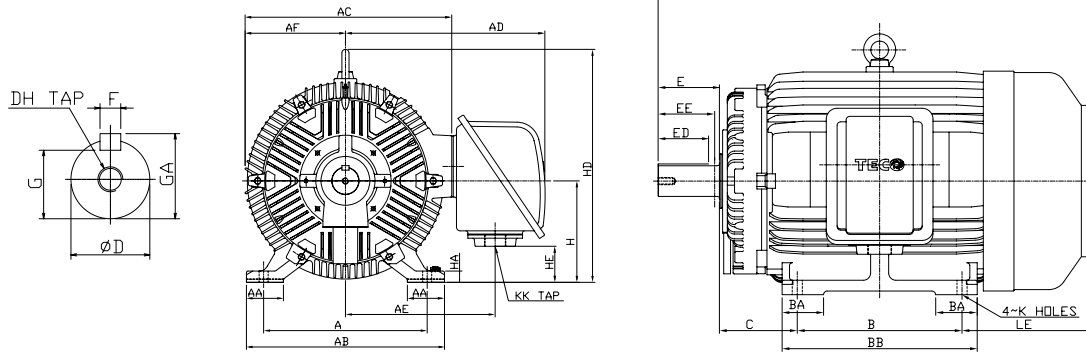

Output (kW)				Frame Size	Dimensions (mm)												
2P	4P	6P	8P		A	AA	AB	AC	AD	AE	AF	B	BA	BB	C	H	HA
90	-	-	-	280SA	457	110	560	603	600	445	293	368	110	445	190	280	30
-	90	55	45	280SC	457	110	560	603	600	445	293	368	110	445	190	280	30
110	-	-	-	280MA	457	110	560	603	600	445	293	419	130	495	190	280	30
-	110	75	55	280MC	457	110	560	603	600	445	293	419	130	495	190	280	30
132	-	-	-	315SA	508	115	615	642	620	465	312	406	115	490	216	315	35
-	132	90	75	315SC	508	115	615	642	620	465	312	406	115	490	216	315	35
150 / 185	-	-	-	315MA	508	115	615	642	620	465	312	457	115	540	216	315	35
-	150	110 / 132	90	315MC	508	115	615	642	620	465	312	457	115	540	216	315	35
-	185	-	-	315MB	508	115	615	642	620	465	312	457	115	540	216	315	35
-	185	-	-	315MC**	508	115	615	642	703	482	312	457	115	540	216	315	35

Frame Size	Shaft						Shaft Extension							Bearings		
	HD	HE	K	KK	L	LE	D	E	ED	EE	F	G	GA	DH	DE	NDE
280SA	651	82	24	M63x1.5	1042	344	65	140	110	134	18	58	69	M20x30	6314C3	6314C3
280SC	651	82	24	M63x1.5	1072	344	80	170	140	157	22	71	85	M20x30	NU318	6316
280MA	651	82	24	M63x1.5	1092	343	65	140	110	134	18	58	69	M20x30	6314C3	6314C3
280MC	651	82	24	M63x1.5	1122	343	80	170	140	157	22	71	85	M20x30	NU318	6316
315SA	723	112	28	M63x1.5	1131	369	65	140	110	134	18	58	69	M20x30	6314C3	6314C3
315SC	723	112	28	M63x1.5	1161	369	85	170	140	157	22	76	90	M20x30	NU320	6316
315MA	723	112	28	M63x1.5	1182	369	65	140	110	134	18	58	69	M20x30	6314C3	6314C3
315MC	723	112	28	M63x1.5	1212	369	85	170	140	157	22	76	90	M20x30	NU320	6316
315MB	723	112	28	M63x1.5	1212	369	85	170	140	157	22	76	90	M20x30	NU320	6316
315MC**	723	112	28	BLANK	1212	369	95	170	140	157	25	86	100	M24x48	NU320	6316

- Notes:**
1. Tolerance refer to [page 33](#).
 2. Usable Shaft Length: EE
 3. ** 185kW motor in D315MC frame with fabricated steel terminal box and oversize DE shaft.
 4. Data subject to change without notice and should not be used for installation purposes.

AEMB MAX-E3-H66 Motor
FRAME SIZES D280-315M



Outline Dimensions Sheet **MAX-E3-H66**

TECO Cast Iron TEFC 3-Phase Squirrel Cage Induction Motors

Frame 315A - 355 Foot Mount AFJE

Totally Enclosed Fan Cooled Squirrel Cage Rotor

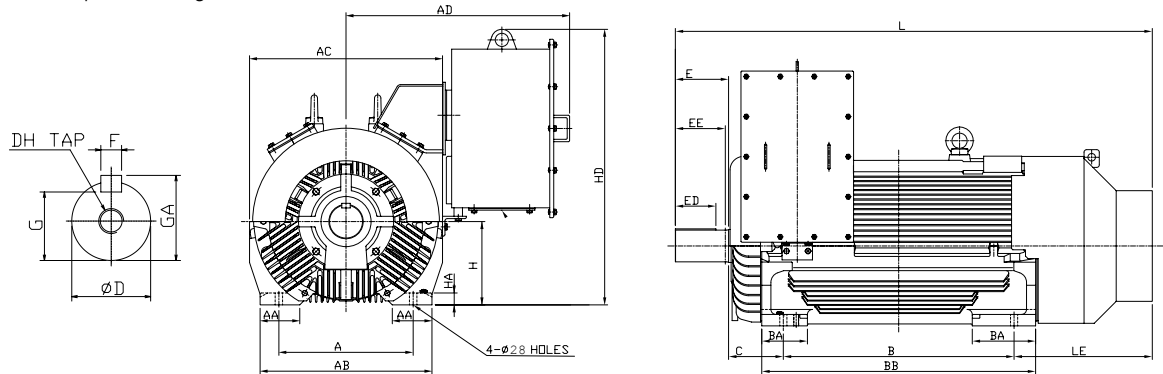

Output (kW)		Frame Size	Dimensions (mm)											
4P	6P		A	AA	AB	AC	AD	B	BA	BB	C	H	HA	HD
-	150 / 185	315AC	508	150	650	730	846	560	180	730	216	315	45	1042
220 / 250	-	315CC	508	150	650	730	846	710	180	880	216	315	45	1042
-	220	315CC	508	150	650	730	846	710	180	880	216	315	45	1042
300 / 375	260	315DC	508	150	650	730	846	910	180	1080	216	315	45	1042
450	-	355CC	610	150	750	810	959	900	210	1120	254	355	45	1227

Output (kW)		Frame Size	Shaft Extension - Direct/Belt Drive										Bearings	
4P	6P		L	LE	D	E	ED	EE	F	G	GA	DH	DE	NDE
-	150 / 185	315AC	1531	545	110	210	160	197	28	100	116	M24X48	NU324C3	6220
220 / 250	-	315CC	1681	545	110	210	160	197	28	100	116	M24X48	NU324C3	6220
-	220	315CC	1681	545	125	210	160	197	32	114	132	M24X48	NU326C3	6220
300 / 375	260	315DC	1881	545	125	210	160	197	32	114	132	M24X48	NU326C3	6220
450	-	355CC	1934	570	125	210	160	197	32	114	132	M24X48	NU326C3	6222

- Notes:**
1. Tolerance refer to [page 33](#).
 2. Usable Shaft Length: EE
 3. Fitted with undrilled blank gland plate.
 4. For Direct Couple application only refer to [TECO](#).
 5. Data subject to change without notice and should not be used for installation purposes.

AFJE MAX-E3-H66 Motor
FRAME SIZES D315A-355



Outline Dimensions Sheet **MAX-E3-H66**

TECO Cast Iron TEFC 3-Phase Squirrel Induction Motors

Frame 80 - 132 Flange Mount

Totally Enclosed Fan Cooled Squirrel Cage Rotor

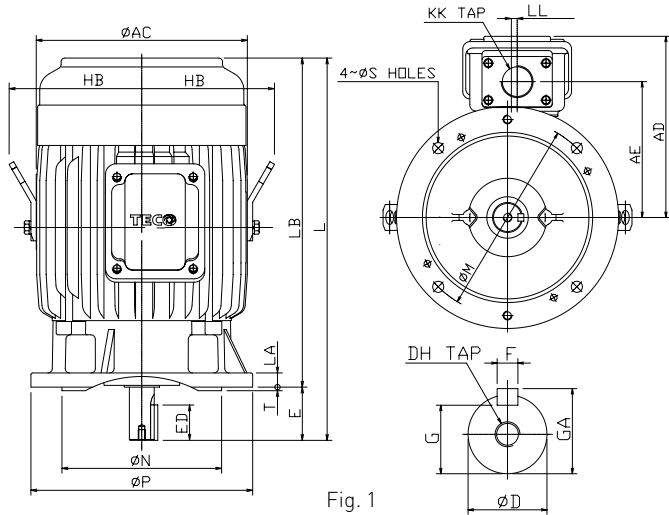

Fig. 1

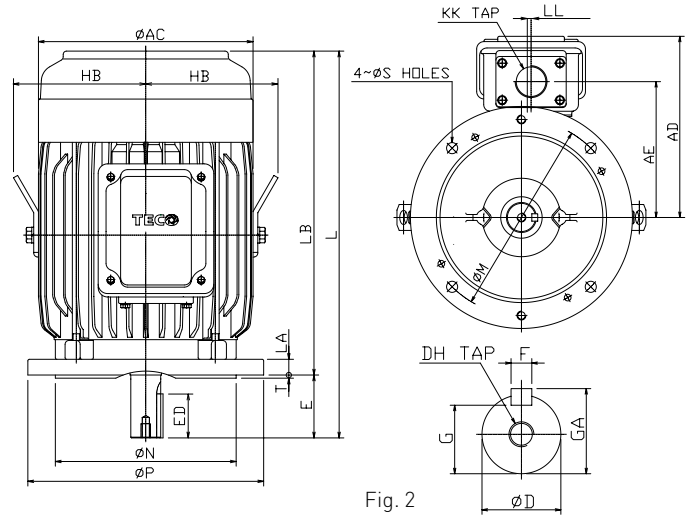

Fig. 2

Output (kW)				Frame Size	Fig. No.	Dimensions (mm)								Flange			
2P	4P	6P	8P			AC	AD	AE	HB	KK	L	LA	LB	LL	M	N	P
0.75 / 1.1	0.55 / 0.75	0.37 / 0.55	0.18	80	2	177	179	130	-	M25 × P1.5	282	12	240	15	165	130	200
1.5	1.1	0.75	0.37	90S	1	200	192	143	-	M25 × P1.5	347	12	297	15	165	130	200
2.2	1.5	1.1	0.55	90L		200	192	143	-	M25 × P1.5	372	12	322	15	165	130	200
3	2.2 / 3	1.5	0.75 / 1.1	100L	2	219	202	153	140	M25 × P1.5	375	16	315	15	215	180	250
4	4	2.2	1.5	112M	1	238	211	162	150	M25 × P1.5	431	16	371	15	215	180	250
5.5 / 7.5	5.5	3	2.2	132S	2	273	249	187	169	M40 × P1.5	454	20	374	13	265	230	300
-	7.5	4 / 5.5	3	132M		273	249	187	169	M40 × P1.5	492	20	404	13	265	230	300

Frame Size	Flange		Shaft Extension							Bearings	
	S	T	D	E	ED	F	G	GA	DH	DE	NDE
80	12	3.5	19	40	25	6	15.5	21.5	M6 × 12	6204ZZ	6204ZZ
90S	12	3.5	24	50	32	8	20	27	M8 × 16	6205ZZ	6205ZZ
90L	12	3.5	24	50	32	8	20	27	M8 × 16	6205ZZ	6205ZZ
100L	14.5	4	28	60	40	8	24	31	M10 × 20	6206ZZ	6305ZZ
112M	14.5	4	28	60	40	8	24	31	M10 × 20	6306ZZ	6306ZZ
132S	14.5	4	38	80	64	10	33	41	M12 × 24	6308ZZ	6306ZZ
132M	14.5	4	38	80	64	10	33	41	M12 × 24	6308ZZ	6306ZZ

- Notes:**
1. Tolerance: Refer to [page 33](#).
 2. Lifting lugs not provided on frames D90 and smaller.
 3. Data subject to change without notice and should not be used for installation purposes.

Outline Dimensions Sheet **MAX-E3-H66**

TECO Cast Iron TEFC 3-Phase Squirrel Induction Motors

Frame 160 - 250 Flange Mount

Totally Enclosed Fan Cooled Squirrel Cage Rotor

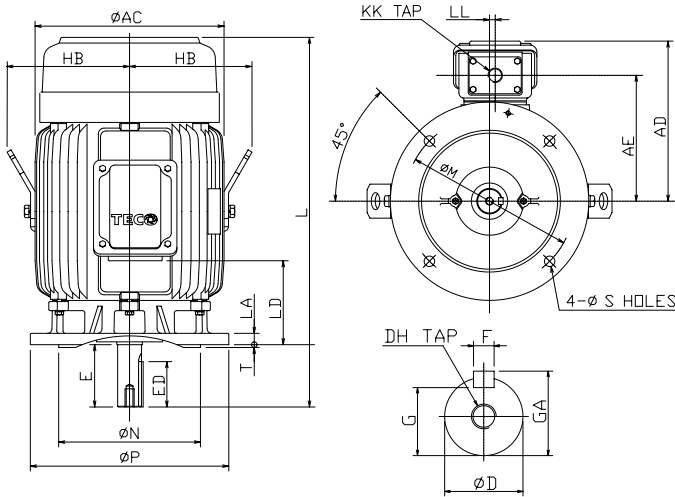

Fig. 3

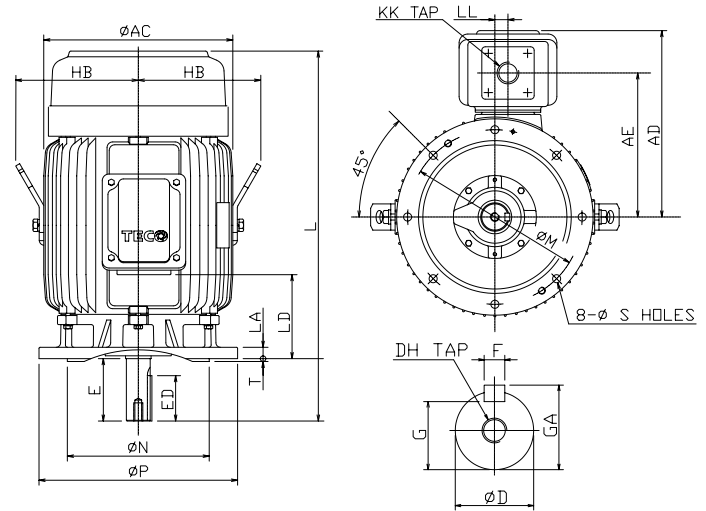

Fig. 4

Output (kW)				Frame Size	Fig. No.	Dimensions (mm)								Flange			
2P	4P	6P	8P			AC	AD	AE	HB	KK	L	LA	LD	LL	M	N	P
11 / 15	11	7.5	4 / 5.5	160M	3	334	287	225	217	M40 × P1.5	608	20	126	10	300	250	350
18.5	15	11	7.5	160L		334	287	225	217	M40 × P1.5	652	20	148	10	300	250	350
22	-	-	-	180MA		382	312	250	241	M40 × P1.5	672	20	155	10	300	250	350
-	18.5	-	-	180MC		382	312	250	241	M40 × P1.5	672	20	155	10	300	250	350
-	22	15	11	180LC		382	312	250	241	M40 × P1.5	710	20	174	10	300	250	350
30 / 37	-	-	-	200LA		420	374	287	260	M50 × P1.5	770	20	154	20	350	300	400
-	30	18.5 / 22	15	200LC		420	374	287	260	M50 × P1.5	770	20	154	20	350	300	400
-	37	-	18.5	225SC		458	427	330	286	M50 × P1.5	816	22	94	30	400	350	450
45	-	-	-	225MA		458	427	330	286	M50 × P1.5	811	22	107	30	400	350	450
-	45	30	22	225MC		458	427	330	286	M50 × P1.5	841	22	107	30	400	350	450
55	-	-	-	250SA	4	510	493	375	312	M63 × P1.5	882.5	22	86	30	500	450	550
-	55	37	30	250SC		510	493	375	312	M63 × P1.5	882.5	22	86	30	500	450	550
75	-	-	-	250MA		510	493	375	312	M63 × P1.5	920.5	22	105	30	500	450	550
-	75	45	37	250MC		510	493	375	312	M63 × P1.5	920.5	22	105	30	500	450	550

Frame Size	Flange		Shaft Extension							Bearings	
	S	T	D	E	ED	F	G	GA	DH	DE	NDE
160M	18.5	5	42	110	80	12	37	45	M16 × 32	6309ZZ	6307ZZ
160L	18.5	5	42	110	80	12	37	45	M16 × 32	6309ZZ	6307ZZ
180MA	18.5	5	48	110	80	14	42.5	51.5	M16 × 32	6211C3	6211C3
180MC	18.5	5	48	110	80	14	42.5	51.5	M16 × 32	6311ZZ	6310ZZ
180LC	18.5	5	48	110	80	14	42.5	51.5	M16 × 32	6311ZZ	6310ZZ
200LA	18.5	5	55	110	80	16	49	59	M20 × 40	6312C3	6212C3
200LC	18.5	5	55	110	80	16	49	59	M20 × 40	6312	6212
225SC	18.5	5	60	140	110	18	53	64	M20 × 40	6313	6213
225MA	18.5	5	55	110	80	16	49	59	M20 × 40	6312C3	6212C3
225MC	18.5	5	60	140	110	18	53	64	M20 × 40	6313	6213
250SA	18.5	5	60	140	110	18	53	64	M20 × 40	6313C3	6213C3
250SC	18.5	5	70	140	110	20	62.5	74.5	M20 × 40	NU316	6313
250MA	18.5	5	60	140	110	18	53	64	M20 × 40	6313C3	6213C3
250MC	18.5	5	70	140	110	20	62.5	74.5	M20 × 40	NU316	6313

- Notes:
1. Tolerance: Refer to [page 33](#).
 2. Data subject to change without notice and should not be used for installation purposes.

Outline Dimensions Sheet MAX-E3-H66

TECO Cast Iron TEFC 3-Phase Squirrel Induction Motors

Frame 80 - 200 Foot and Flange Mount

Totally Enclosed Fan Cooled Squirrel Cage Rotor

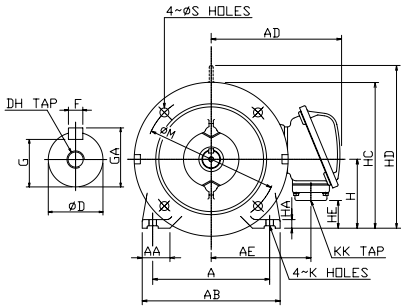

Fig. 1

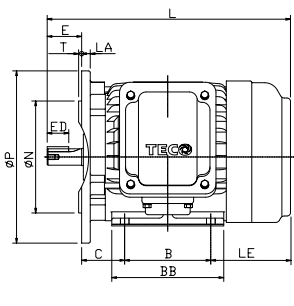

Fig. 2

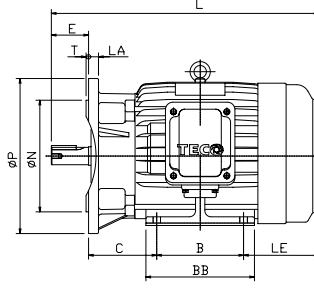

Fig. 3

Output (kW)				Frame Size	Fig. No.	Dimensions (mm)														
2P	4P	6P	8P			A	AA	AB	AD	AE	B	BB	C	H	HA	HC	HD	HE	K	KK
0.75 / 1.1	0.55 / 0.75	0.37 / 0.55	0.18	80	1	125	35.5	155	179	130	100	130	50	80	9	180	-	13	10	M25 × P1.5
1.5	1.1	0.75	0.37	90S	2	140	35.5	170	192	143	100	130	95	90	10	190	-	23	10	M25 × P1.5
2.2	1.5	1.1	0.55	90L		140	35.5	170	192	143	125	150	95	90	10	190	-	23	10	M25 × P1.5
3	2.2 / 3	1.5	0.75 / 1.1	100L		160	45	195	202	153	140	175	103	100	12.5	-	243	33	12	M25 × P1.5
4	4	2.2	1.5	112M		190	45	224	211	162	140	175	110	112	14	-	265	45	12	M25 × P1.5
5.5 / 7.5	5.5	3	2.2	132S		216	45	250	249	187	140	175	139	132	16	-	310	58	12	M40 × P1.5
-	7.5	4 / 5.5	3	132M		216	45	250	249	187	178	212	139	132	16	-	310	58	12	M40 × P1.5
11 / 15	11	7.5	4 / 5.5	160M		254	50	300	287	225	210	250	108	160	18	-	377	83	14.5	M40 × P1.5
18.5	15	11	7.5	160L	254	50	300	287	225	254	300	108	160	18	-	377	83	14.5	M40 × P1.5	
22	-	-	-	180MA	279	75	355	312	250	241	297	121	180	20	-	421	103	14.5	M40 × P1.5	
-	18.5	-	-	180MC	279	75	355	312	250	241	297	121	180	20	-	421	103	14.5	M40 × P1.5	
-	22	15	11	180LC	279	75	355	312	250	279	335	121	180	20	-	421	103	14.5	M40 × P1.5	
30/37	-	-	-	200LA	318	80	400	374	287	305	365	133	200	25	-	469	88	18.5	M50 × P1.5	
-	30	18.5 / 22	15	200LC	318	80	400	374	287	305	365	133	200	25	-	469	88	18.5	M50 × P1.5	

Frame Size	Flange								Shaft Extension							Bearings	
	LA	LE	L	M	N	P	S	T	D	E	ED	F	G	GA	DH	DE	NDE
80	12	92.5	282.5	165	130	200	12	3.5	19	40	25	6	15.5	21.5	M6 × 12	6204ZZ	6204ZZ
90S	12	101.5	346.5	165	130	200	12	3.5	24	50	32	8	20	27	M8 × 16	6205ZZ	6205ZZ
90L	12	101.5	371.5	165	130	200	12	3.5	24	50	32	8	20	27	M8 × 16	6205ZZ	6205ZZ
100L	16	112	414.5	215	180	250	14.5	4	28	60	40	8	24	31	M10 × 20	6206ZZ	6305ZZ
112M	16	121.5	431.5	215	180	250	14.5	4	28	60	40	8	24	31	M10 × 20	6306ZZ	6306ZZ
132S	20	145	504	265	230	300	14.5	4	38	80	64	10	33	41	M12 × 24	6308ZZ	6306ZZ
132M	20	145	542	265	230	300	14.5	4	38	80	64	10	33	41	M12 × 24	6308ZZ	6306ZZ
160M	20	180	608	300	250	350	18.5	5	42	110	80	12	37	45	M16 × 32	6309ZZ	6307ZZ
160L	20	180	652	300	250	350	18.5	5	42	110	80	12	37	45	M16 × 32	6309ZZ	6307ZZ
180MA	20	200	672	300	250	350	18.5	5	48	110	80	14	42.5	51.5	M16 × 32	6211C3	6211C3
180MC	20	200	672	300	250	350	18.5	5	48	110	80	14	42.5	51.5	M16 × 32	6311ZZ	6310ZZ
180LC	20	200	710	300	250	350	18.5	5	48	110	80	14	42.5	51.5	M16 × 32	6311ZZ	6310ZZ
200LA	20	222	770	350	300	400	18.5	5	55	110	80	16	49	59	M20 × 40	6312C3	6212C3
200LC	20	222	770	350	300	400	18.5	5	55	160	80	16	49	59	M20 × 40	6312	6212

- Notes:**
1. Tolerance: Refer to [page 33](#).
 2. Eyebolts not provided on frames D90 and smaller.
 3. Data subject to change without notice and should not be used for installation purposes.

Outline Dimensions Sheet **MAX-E3-H66**

TECO Cast Iron TEFC 3-Phase Squirrel Induction Motors

Frame 225 - 315M Foot and Flange Mount

Totally Enclosed Fan Cooled Squirrel Cage Rotor

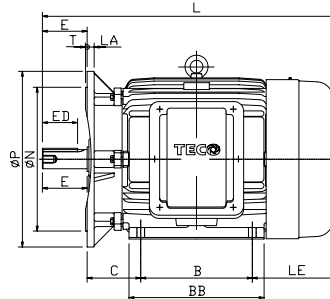
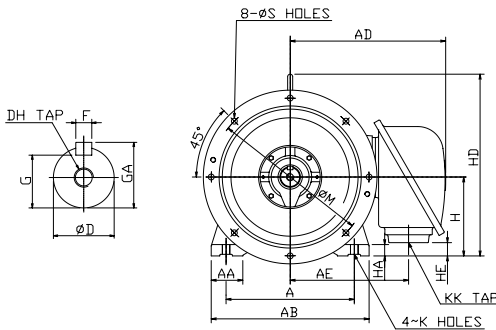

Fig. 4

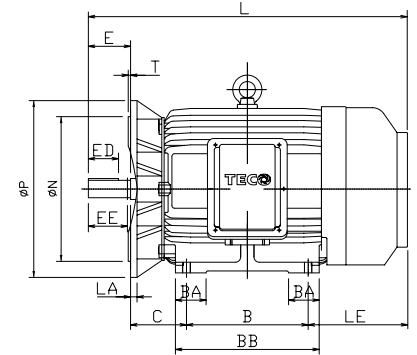

Fig. 5

Output (kW)				Frame Size	Fig. No.	Dimensions (mm)														
2P	4P	6P	8P			A	AA	AB	AD	AE	B	BA	BB	C	H	HA	HD	HE	K	KK
-	37	-	18.5	225SC	4	356	90	450	427	330	286	-	350	149	225	30	524	57	18.5	M50 × P1.5
45	-	-	-	225MA		356	90	450	427	330	311	-	375	149	225	30	524	57	18.5	M50 × P1.5
-	45	30	22	225MC		356	90	450	427	330	311	-	375	149	225	30	524	57	18.5	M50 × P1.5
55	-	-	-	250SA		406	100	500	493	375	311	-	385	168	250	36	575	42	24	M63 × P1.5
-	55	37	30	250SC		406	100	500	493	375	311	-	385	168	250	36	575	42	24	M63 × P1.5
75	-	-	-	250MA		406	100	500	493	375	349	-	425	168	250	36	575	42	24	M63 × P1.5
-	75	45	37	250MC		406	100	500	493	375	349	-	425	168	250	36	575	42	24	M63 × P1.5
90	-	-	-	280SA		5	457	110	560	600	445	368	110	445	190	280	30	651	82	24
-	90	55	45	280SC	457		110	560	600	445	368	110	445	190	280	30	651	82	24	M63 × P1.5
110	-	-	-	280MA	457		110	560	600	445	419	110	495	190	280	30	651	82	24	M63 × P1.5
-	110	75	55	280MC	457		110	560	600	445	419	110	495	190	280	30	651	82	24	M63 × P1.5
132	-	-	-	315SA	508		115	615	600	465	406	115	490	216	315	35	723	112	28	M63 × P1.5
-	132	90	75	315SC	508		115	615	600	465	406	115	490	216	315	35	723	112	28	M63 × P1.5
150 / 185	-	-	-	315MA	508		115	615	600	465	457	115	540	216	315	35	723	112	28	M63 × P1.5
-	150	110 / 132	90	315MC	508		115	615	600	465	457	115	540	216	315	35	723	112	28	M63 × P1.5
-	185	-	-	315MB	508	115	615	600	465	457	115	540	216	315	35	723	112	28	M63 × P1.5	

Frame Size	Flange								Shaft Extension							Bearings		
	LA	LE	L	M	N	P	S	T	D	E	ED	EE	F	G	GA	DH	DE	NDE
225SC	22	241	816	400	350	450	18.5	5	60	140	110	-	18	53	64	M20 × 40	6313	6213
225MA	22	241	811	400	350	450	18.5	5	55	110	80	-	16	49	59	M20 × 40	6312C3	6212C3
225MC	22	241	841	400	350	450	18.5	5	60	140	110	-	18	53	64	M20 × 40	6313	6213
250SA	22	263.5	882.5	500	450	550	18.5	5	60	140	110	-	18	53	64	M20 × 40	6313C3	6213C3
250SC	22	263.5	882.5	500	450	550	18.5	5	70	140	110	-	20	62.5	74.5	M20 × 40	NU316	6313
250MA	22	263.5	920.5	500	450	550	18.5	5	60	140	110	-	18	53	64	M20 × 40	6313C3	6213C3
250MC	22	263.5	920.5	500	450	550	18.5	5	70	140	110	-	20	62.5	74.5	M20 × 40	NU316	6313
280SA	22	344	1042	500	450	550	18.5	5	65	140	110	134	18	58	69	M20 × 40	6314C3	6314C3
280SC	22	344	1072	500	450	550	18.5	5	80	170	140	157	22	71	85	M20 × 40	NU318	6316
280MA	22	344	1092	500	450	550	18.5	5	65	140	110	134	18	58	69	M20 × 40	6314C3	6314C3
280MC	22	344	1122	500	450	550	18.5	5	80	170	140	157	22	71	85	M20 × 40	NU318	6316
315SA	25	369	1131	600	550	660	24	6	65	140	110	134	18	58	69	M20 × 40	6314C3	6314C3
315SC	25	369	1161	600	550	660	24	6	85	170	140	157	22	76	90	M20 × 40	NU320	6316
315MA	25	369	1182	600	550	660	24	6	65	140	110	134	18	58	69	M20 × 40	6314C3	6314C3
315MC	25	369	1212	600	550	660	24	6	85	170	140	157	22	76	90	M20 × 40	NU320	6316
315MB	25	369	1212	600	550	660	24	6	85	140	140	157	22	76	90	M20 × 40	NU320	6316

- Notes:
1. Tolerance: Refer to [page 33](#).
 2. Usable Shaft length: EE
 3. Data subject to change without notice and should not be used for installation purposes.

Outline Dimensions Sheet *MAX-E3-H66*

TECO Cast Iron TEFC 3-Phase Squirrel Induction Motors

Frame 80 - 132 Foot and C Face Mount

Totally Enclosed Fan Cooled Squirrel Cage Rotor

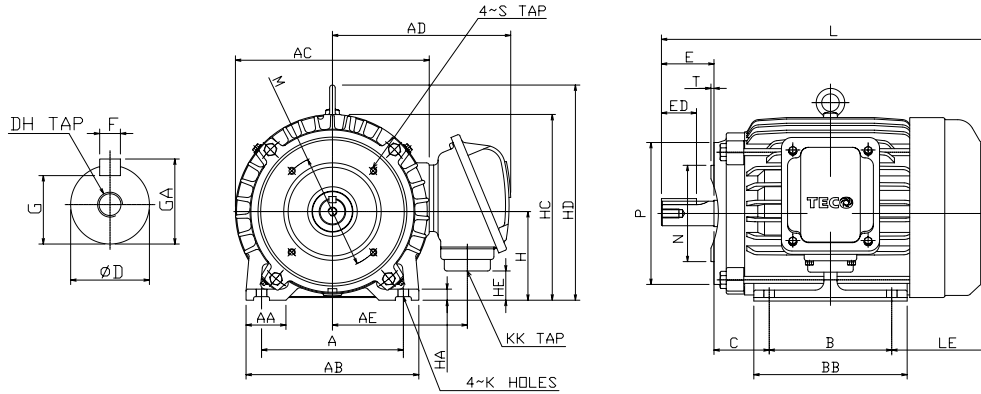

Fig. 1

Output (kW)				Frame Size	Fig. No.	Dimensions (mm)															
2P	4P	6P	8P			A	AA	AB	AC	AD	AE	B	BB	C	H	HA	HC	HD	HE	K	KK
0.75 / 1.1	0.55 / 0.75	0.37 / 0.55	0.18	80	1	125	35.5	155	177	179	130	100	130	50	80	9	168	-	13	10	M25 × P1.5
1.5	1.1	0.75	0.37	90S		140	35.5	170	200	192	143	100	130	56	90	10	190	-	23	10	M25 × P1.5
2.2	1.5	1.1	0.55	90L		140	35.5	170	200	192	143	125	150	56	90	10	190	-	23	10	M25 × P1.5
3	2.2 / 3	1.5	0.75 / 1.1	100L		160	45	195	219	202	153	140	175	63	100	12.5	-	243	33	12	M25 × P1.5
4	4	2.2	1.5	112M		190	45	224	238	211	162	140	175	70	112	14	-	265	45	12	M25 × P1.5
5.5 / 7.5	5.5	3	2.2	132S		216	45	250	273	249	187	140	175	89	132	16	-	310	58	12	M40 × P1.5
-	7.5	4 / 5.5	3	132M		216	45	250	273	249	187	178	212	89	132	16	-	310	58	12	M40 × P1.5

Frame Size			Flange					Shaft Extension							Bearings	
	LE	L	M	N	P	S	T	D	E	ED	F	G	GA	DH	DE	NDE
80	92	282	100	80	120	M6	3.5	19	40	25	6	15.5	21.5	M6 × 12	6204ZZ	6204ZZ
90S	140	346	115	95	140	M8	3.5	24	50	32	8	20	27	M8 × 16	6205ZZ	6205ZZ
90L	140	371	115	95	140	M8	3.5	24	50	32	8	20	27	M8 × 16	6205ZZ	6205ZZ
100L	111	374	130	110	160	M8	4	28	60	40	8	24	31	M10 × 20	6206ZZ	6305ZZ
112M	161	431	130	110	160	M8	4	28	60	40	8	24	31	M10 × 20	6306ZZ	6306ZZ
132S	145	454	165	130	200	M10	4	38	80	64	10	33	41	M12 × 24	6308ZZ	6306ZZ
132M	145	492	165	130	200	M10	4	38	80	64	10	33	41	M12 × 24	6308ZZ	6306ZZ

- Notes:**
1. Tolerance: Refer to [page 33](#).
 2. Eyebolts not provided on frames D90 and smaller.
 3. Data subject to change without notice and should not be used for installation purposes.

Mechanical Design



Axial / Radial Loadings

The table below gives the permissible axial and radial loads. The values are based on normal conditions at 50 Hz and a calculated L10 bearing life of 40,000 hours.

Frame Size	Radial Load Horizontal Shaft	Axial Load Horizontal Shaft	Axial Load Shaft Down (down thrust)	Axial Load Shaft Down (up thrust)
80	47 kg	69 kg	65 kg	73 kg
90	49 kg	73 kg	66.5 kg	79.5 kg
100	72 kg	105 kg	95 kg	115 kg
112	95 kg	138 kg	124 kg	152 kg
132	147 kg	143 kg	123 kg	163 kg
160	179 kg	174 kg	134 kg	214 kg
180	248 kg	238 kg	182 kg	292 kg
200	297 kg	290 kg	210 kg	370 kg
225	305 kg	310 kg	230 kg	390 kg
250	1400 kg	325 kg	320 kg	510 kg
280	1500 kg	-	-	-
315M	1650 kg	-	-	-

- Notes:**
1. Based on 4 Pole motors, bearing life L-10 40,000 hours.
 2. For radial load overhung point at centre of shaft extension.
 3. For other loadings, [please contact TECO](#).

Axial Radial Loadings - Foot

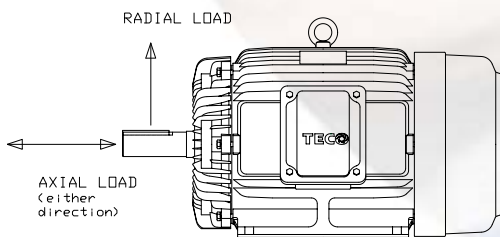

Axial Radial Loadings - Flange

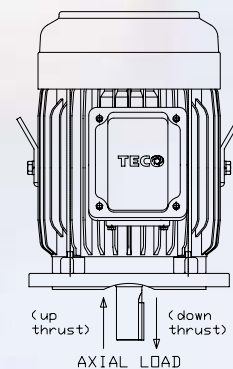

Cooling

Designation System Concerning Methods of Cooling Refers to Standard AS1359.106.

Standard Code Example

Code	Description	Type
IC 01	Self-cooling open machine.	
IC411	Enclosed machine. Smooth or finned ventilated casing. External shaft-mounted fan.	
IC416	Enclosed machine. Smooth or finned ventilated casing. External motorized axial fan supplied with machine.	

Example

Code		IC	4	(A)	1	(A)	6
International Cooling							
Circuit Arrangement	0 : Free circulation (open circuit) 4 : Frame surface cooled						
Primary Coolant	A : Air (omitted for simplified designation)						
Method of Movement of Primary Coolant	0 : Free convection 1 : Self-circulation 6 : Machine-mounted independent component						
Secondary Coolant	A : Air (omitted for simplified designation) W : Water						
Method of Movement of Secondary Coolant	0 : Free convection 1 : Self-circulation 6 : Machine-mounted independent component						

Cooling air flows from the non-drive-end to the drive end. When the motor is installed care should be taken not to impede the airflow into the motor fan cover. As a guide the following minimum dimension BL should be adopted.

Motor Frame	Dimensions BL (mm)
80 - 100	60
112 - 132	85
160 - 180	85
200 - 250	110
280	140
315 - 355	180

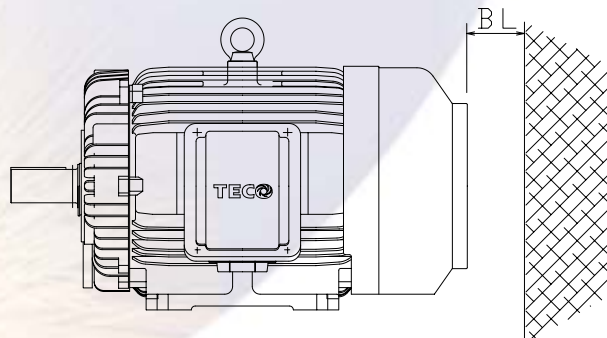

Force Cooling IC416

TECO can offer force cooling on most TEFC motors, listed below are common sizes with details (larger sizes [please refer to TECO](#)). All force cooling motors are 230 ~ 240 Volts Single Phase 50 Hz and are IP55 as standard. Fan motor leads are terminated in an auxiliary terminal box mounted on the fan cover.

Frame Size	Motor Watts	Amps	Force Cooling Unit length "Lfc" in mm
D80	17	0.1	95
D90	29	0.12	95
D100	29	0.12	90
D112	46	0.22	105
D132	46	0.22	85
D160	75	0.42	140
D180	75	0.42	135
D200	135	0.59	95

Notes: 1. Dimensions subject to change.

*Typical Force Cooling Unit.
View from the inside.*



Force Cooling Lfc

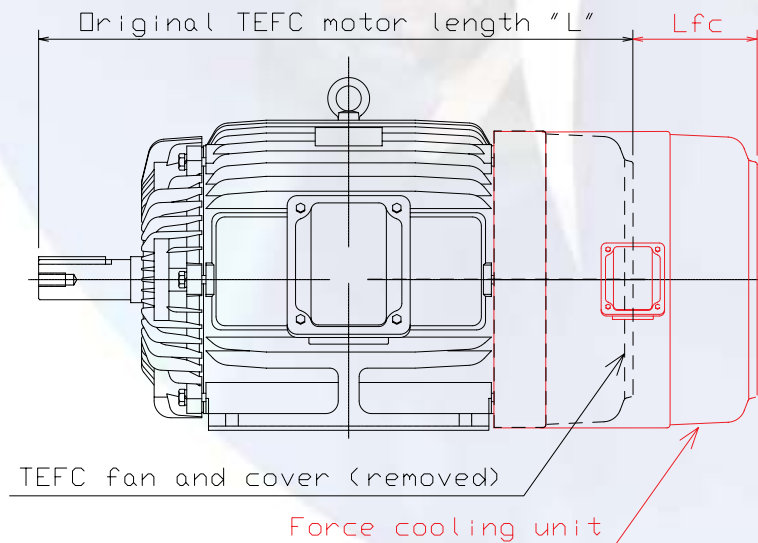

Mounting (IM code)

Mounting Arrangement (IM)

Foot Mounted		Flange Mounted		Foot / Flange Mounted	
IM 1001 (IM B3) Horizontal Shaft. Foot mounted.		IM 3001 (IM B5) Horizontal Shaft. 'D' type flange at D.E. No feet.		IM 2001 (IM B35) Horizontal Shaft. 'D' type flange at D.E. Foot mounted.	
IM 1051 (IM B6) Horizontal Shaft. Foot wall mounted with feet on left-side when viewed from D.E.		IM 3011 (IM V1) Vertical Shaft. 'D' type flange at D.E. Shaft down. No feet.		IM 2011 (IM V15) Vertical Shaft. 'D' type flange at D.E. Wall mounted. Shaft down.	
IM 1061 (IM B7) Horizontal Shaft. Foot wall mounted with feet on right-side when viewed from D.E.		IM 3031 (IM V3) Vertical Shaft. 'D' type flange at D.E. Shaft up. No feet.		IM 2031 (IM V36) Vertical Shaft. 'D' type flange at D.E. Wall mounted. Shaft up.	
IM 1071 (IM B8) Horizontal Shaft. Ceiling mounted with feet above motor.		IM 3601 (IM B14) Horizontal Shaft. 'C' type flange at D.E. No feet.		IM 2101 (IM B34) Horizontal Shaft. 'C' type flange at D.E. Foot mounted.	
IM 1011 (IM V5) Vertical Shaft. Wall mounted. Shaft down.		IM 3611 (IM V18) Vertical Shaft. 'C' type flange at D.E. Shaft down. No feet.		IM 2111 Vertical Shaft. 'C' type flange at D.E. Wall mounted. Shaft down.	
IM 1031 (IM V6) Vertical Shaft. Wall mounted. Shaft up.		IM 3631 (IM V19) Vertical Shaft. 'C' type flange at D.E. Shaft up. No feet.		IM 2131 Vertical Shaft. 'C' type flange at D.E. Wall mounted. Shaft up.	

It is important to nominate the "IM" code at enquiry and order stage to ensure that drain holes are in the correct position and bearing arrangement is checked for suitability if the "IM" code differs from standard.

Standard Mounting Arrangement

TECO Stock Motors - Standard Mounting Arrangement and Terminal Box Position				
Mounting	IM Code	(IM Code)	Terminal box position (viewed from drive end)	Cable entry direction
Foot	IM1001	IMB3	Right	From below
Flange	IM3011	IMV1	As needed (motor can be rotated)	From flange end
Foot & Flange	IM2001	IMB35	Right	From below

Mounting - Cast Iron Slide Rails - Dimensions

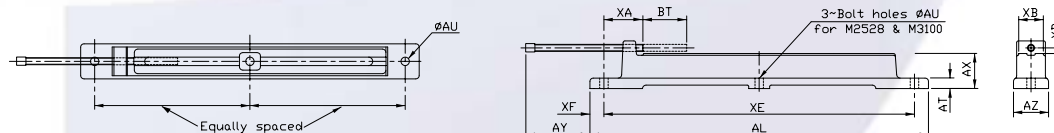

SLIDE RAIL	FRAME SIZE	AL	AT	AU	AX	AY	AZ	BT min.	XA max.	XB	XD	XE	XF
M0809	80	355	12	10	30	105	35	95	45	30	6	325	15
	90	355	12	10	30	105	35	80	45	30	6	325	15
M1013	100	470	16	12	44	170	52	160	50	43	6	430	18
	112	470	16	12	44	170	52	125	50	43	6	430	18
	132	470	16	12	44	170	52	100	50	43	6	430	18
M1618	160	615	19	15	64	170	76	155	67	57	11	565	25
	180	615	19	15	64	170	76	125	67	57	11	565	25
M2022	200	780	25	19	82	210	100	190	80	82	12	725	27
	225	780	25	19	82	210	100	140	80	82	12	725	27
M2528	250	965	30	24	100	275	100	250	86	82	16	885	40
	280	965	30	24	100	275	100	190	86	82	16	885	40
M3100	315	1215	40	38	125	380	123	330	110	95	20	1115	50

Protection (IP code)

Protection (IP)

First number: Protection against solid objects			Second number: Protection against liquids		
IP	Tests	Definition	IP	Tests	Definition
0		No protection.	0		No protection.
1		Protected against solid objects of over 50mm (e.g. accidental hand contact).	1		Protected against vertically dripping water (condensation).
2		Protected against solid objects of over 12mm (e.g. finger).	2		Protected against water dripping up to 15° from the vertical.
3		Protected against solid objects of over 2.5mm (e.g. tools, wire).	3		Protected against rain falling at up to 60° from the vertical.
4		Protected against solid objects of over 1mm (e.g. thin wire).	4		Protected against water splashes from all directions.
5		Protected against dust (e.g. no deposits of harmful material).	5		Protected against jets of water from all directions.
6		Totally protected against dust.	6		Protected against jets of water comparable to heavy seas.
			7		Protected against effects of immersion to depths of between 0.15 and 1m.
			8		Protected against the effects of prolonged immersion at depth.

Electrical Design

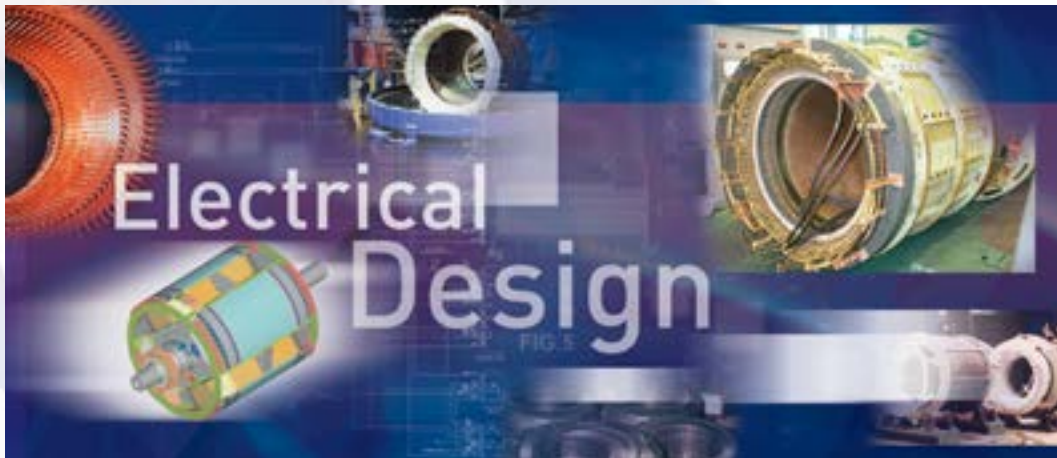

Altitude and Ambient Temperature

Rated output power specified in the performance data tables apply for standard ambient conditions of 40°C up to 1000 m above sea level. Where temperature or altitude differ from the standard, multiplication factors in the table below should be used if motor temperature rise is to be maintained.

Ambient Temperature	Temperature Factor	Altitude above sea level	Altitude Factor
30°C	1.06	1000 m	1
35°C	1.03	1500 m	0.97
40°C	1	2000 m	0.945
45°C	0.97	2500 m	0.92
50°C	0.93	3000 m	0.89
55°C	0.9	3500 m	0.865
60°C	0.865	4000 m	0.835

- Notes:**
1. Effective Power = [Rated Power] x [Temperature Factor] x [Altitude Factor]
 2. The low temperature rise of TECO motors in many instances preclude the need for derating, [please refer to TECO.](#)

Earth Topography

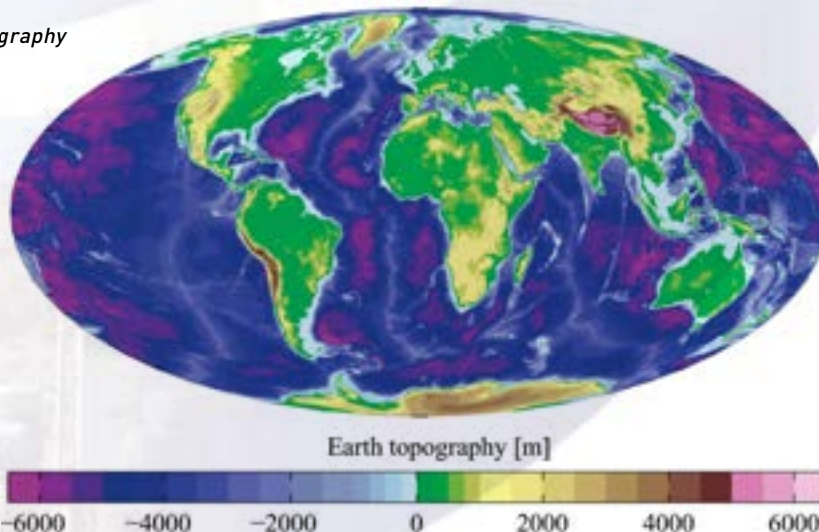

Anti-Condensation Heaters (Optional)

Anti-condensation heaters are used to prevent the water accumulation caused by moisture condensation inside the motor. These are flexible type elements and tied on the ends of the winding to maintain the average temperature of the motor above dew point. The heaters must be switched on when the machine stops and switched off whilst the machine is in operation. A prominent warning label is fitted with the appropriate rating of the heaters nominated.

The space heater leads are normally terminated to an auxiliary terminal box for safety reasons.

The normal supply of space heaters is single phase 240V, other voltages can be supplied on request.

Power Rating of Anti-Condensation Heaters

Heater length varies to suit diameter of end-winding.

Frame Size	Power in Watts
80 - 100	25
112	21
132 - 160	40
180 - 200	26
225 - 250	42
280	54
315M	99
315A	200
355	250

Connection Diagrams

TECO motors are connected as shown on the motor nameplate, typical Star or Delta connection diagram is shown below.

TECO stock motors 4 kW and below are 380~415 Volt 50 Hz STAR connected and may

also be reconnected to 240 Volt 3-Phase 50 Hz DELTA configuration for use with single phase input inverters.

Motors 5.5 kW and larger are 380~415 Volt 50 Hz DELTA connected.

STAR CONNECTION

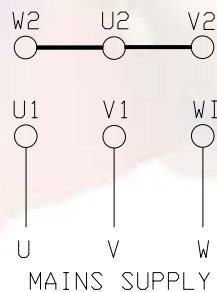

DELTA CONNECTION

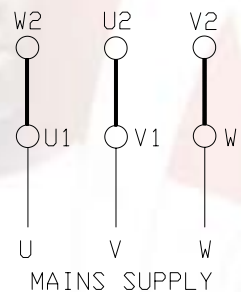

Duty

TECO motors are supplied suitable for S1 operation (continuous operation under rated load). When the motor is to operate under any other type of duty the following information should be supplied to determine the correct motor size.

- Type and frequency of switching (short time, intermittent, periodic, high inertia, braking).

- Load torque variation during motor acceleration and braking (in graphical form).
- Moment of inertia of the load on the motor shaft.
- Type of braking (e.g. mechanical, electrical through phase reversal or DC injection.)
- For duty cycles other than S1 [please refer to TECO.](#)

Efficiency

Energy use is the dominant source of greenhouse gas emissions in Australia.

TECO is committed to produce high efficiency motors in order to reduce the energy consumed and in turn reduce greenhouse gas emissions.

The **MAX-E3-H66** TECO motors meet the High Efficiency level of MEPS 2004 as standard.

Minimum Efficiency Performance Standard AS1359.5 (MEPS) was first introduced in 2000, then revised to meet world's best practice in 2004 and became mandatory in 2006. The graph below shows the improvement in efficiencies and the level of **TECO MAX-E3-H66 High Efficiency Motors**.

Efficiency Comparison Table

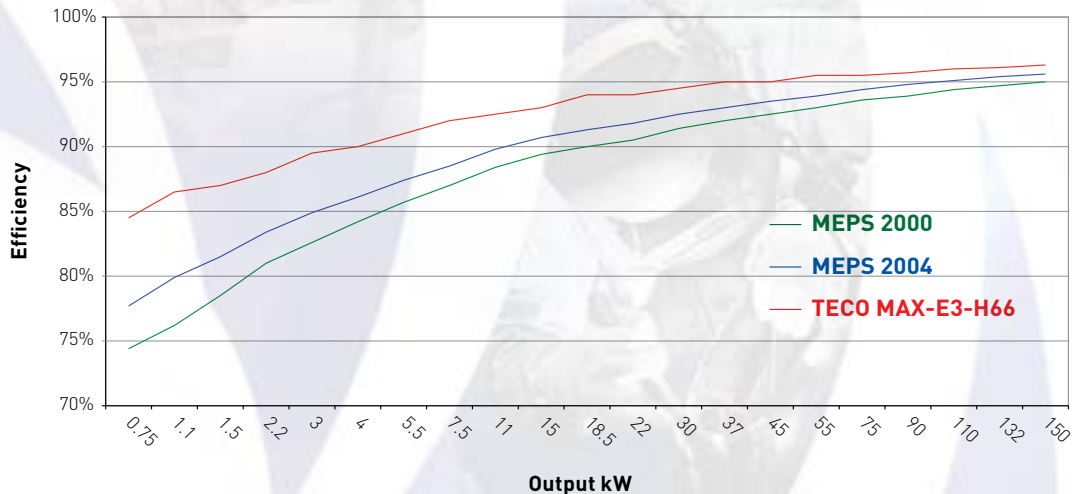

Operating Cost Saving

How much money can be saved in the first year of operation?

Typical cost saving on a 75 kW 4 Pole motor can be calculated as follows:

$$S = kW \times N \times C (100/E1 - 100/E2)$$

S = Savings in \$ per year

KW = Rated motor output (kW)

C = Energy cost per kW/hr = \$ 0.10

N = Running time in hrs/year = 8760 hrs

E1 = Efficiency of a standard motor (MEPS2000) = 93.6%

E2 = Efficiency of TECO MAX-E3™ motor = 95.7%

Calculation Example:

$$S = 75 \times 8760 \times 0.10 \times (100/93.6 - 100/95.7) = \$ 1,468 \text{ Operational cost saving per year}$$

$$\text{Saving over a 20 year period} = \$ 29,360$$



Cost saving on the environment?

Electric motors are responsible for the majority of electricity consumption in the industrial and commercial sectors. Typical applications include crushing, grinding, mixing, fans, pumps, materials conveying, air compressors, ventilation and refrigeration. In total, experts estimate that electric motors account for nearly 30% of total electricity consumption in Australia for all sectors or around some 11% of total greenhouse gas emissions. By utilizing **TECO MAX-E3-H66 High Efficiency Motors** you will not only save money but also reduce our carbon footprint.

Formulae and Conversions

Electric Motor characteristics

Output Power

$$P \text{ (kW)} = \frac{M \times n}{9550}$$

Output Power

$$P_{\text{mec}} = \frac{\sqrt{3} \times U \times I \times \cos \theta \times \eta}{1000}$$

Output Torque

$$M = \frac{9550 \times P}{n}$$

Star Delta Starting

$$\text{Torque (Star)} = \frac{\text{Full Load Torque (Delta)}}{0.333}$$

$$\text{Current (Star)} = \frac{\text{Full Load Current (Delta)}}{0.577}$$

3-Phase Input Power

$$P_{\text{el}} = \frac{\sqrt{3} \times U \times I \times \cos \theta}{1000}$$

Efficiency

$$\eta = \frac{\text{Output kW}}{\text{Input kW}}$$

$$\eta = \frac{P_{\text{mec}} \times 1000}{\sqrt{3} \times U \times I \times \cos \theta}$$

Motor Current

$$I = \frac{P_{\text{mec}} \times 1000}{\sqrt{3} \times U \times \cos \theta \times \eta}$$

$$I = \frac{P_{\text{elec}} \times 1000}{\sqrt{3} \times U \times \cos \theta}$$

I - Motor current, can be calculated for full or partial loadings.

Use Efficiency and Power Factor relative to motor loadings.

Motor Speed

$$n = 120 \times \frac{f}{\text{Poles}}$$

Hz	Number of Poles - Synchronous Speed					
	2	4	6	8	10	12
50	3000	1500	1000	750	600	500
60	3600	1800	1200	900	720	600

Key: P = Power in kW
Subscript
 P_{el} = electrical
 P_{mec} = mechanical

m = Torque in Nm
 n = Rotational speed in r/min
 U = Line voltage in V
 I = Line current in A
 cos θ = Power factor (per unit)
 η = Motor efficiency (per unit)
 f = Frequency in Hz
 J = WR² = WK²

Conversions

Length

	m	cm	mm
1 m =	1	100	1000
1 mm =	0.001	0.1	1
1 ft =	0.3048	30.48	304.8
1 in =	0.254	2.54	25.4

m = meter, cm - centimeter, mm = millimeter

Force and weight

	N	kp	p
1 N =	1	0.102	102
1 kp =	9.807	1	1000
1 lbf =	4.448	0.4536	453.6
1 in =	0.254	2.54	25.4

Velocity

	km/h	m/min	m/s
1 km/h =	1	16.667	0.2778
1 m/min =	0.06	1	16.7 x 10 ⁻³
1m/s =	3.6	60	1
1 in =	0.254	2.54	25.4

Torque

	Nm	kgfm
1 Nm =	1	0.10197
1 kgfm =	9.8067	1
1 lbf.ft =	1.356	0.1383
1 lbf.in =	0.1129	11.5 x 10 ⁻³

Power

	kW	hp
1 kW =	1	1.341
1 hp =	0.7457	1

Moment of inertia

	kgm ² (J)	kgfm ² (GD ²)
1 kgm ² (J) =	1	4
1 kgfm ² (GD ²) =	0.25	1

Insulation Classes

The graph below indicates the limits of winding temperature and temperature rise for the various insulation classes in accordance with AS60034-1 Items 1b) & 1d) AC motors.

The difference between the temperature rise and the insulation class rating equates to the safety margin available.

The majority of TECO motors comply with a limitation of Class E temperature rise (75°C) or less thereby providing a massive thermal reserve, which provides the client with a motor that will perform extremely well in arduous temperature applications whether this be load or ambient induced.

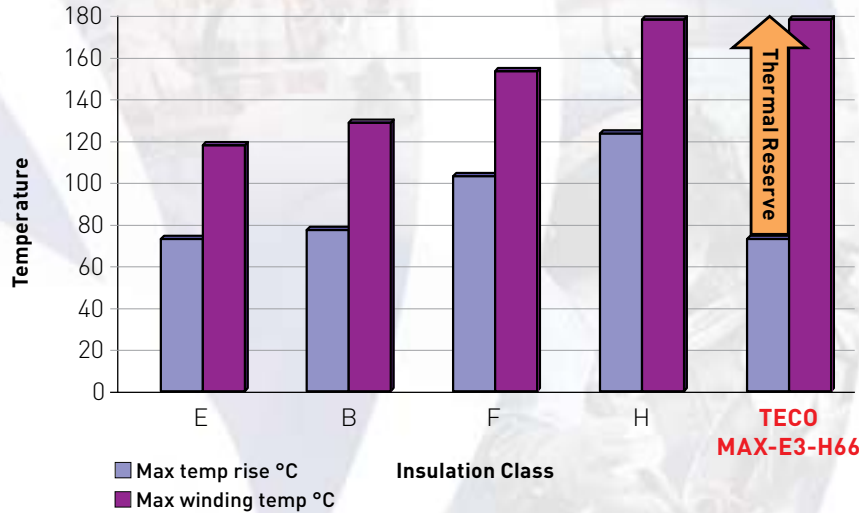

Speed vs. Torque - Current

The graph below indicates the typical speed vs. torque current characteristics of a D132 frame motor to "Design N" Normal Torque. The motor is started DOL and the major points on these curves are defined below.

Speed vs. Torque - Current Curves

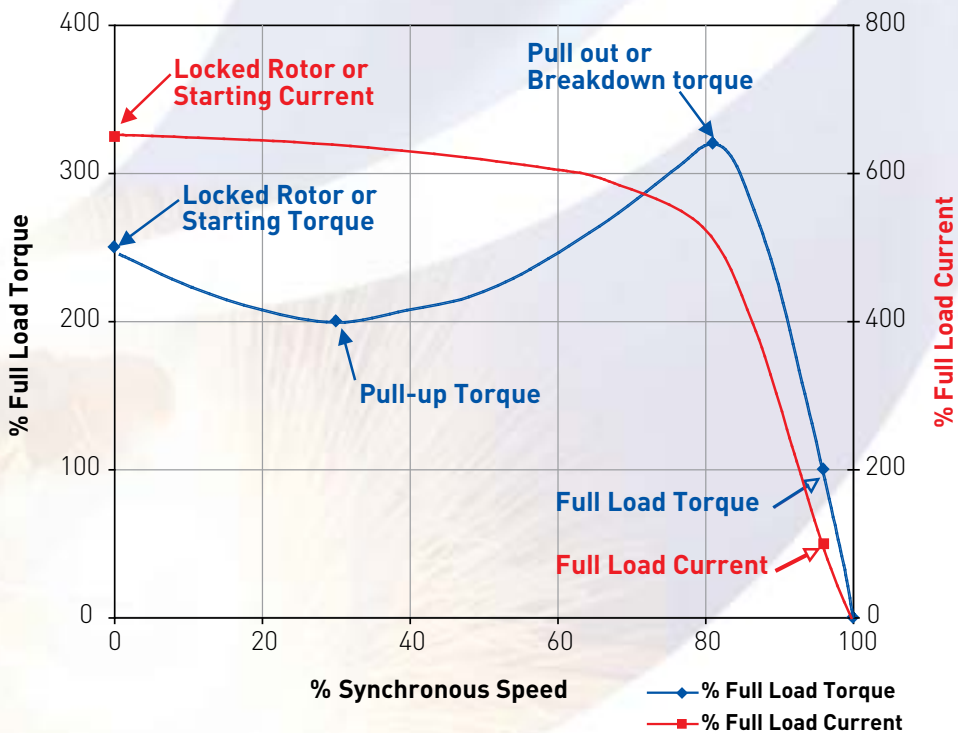

Starts Per Hour

Starts Per Hour and Maximum Load Inertia

Maximum starts per hour DOL based on maximum load inertia listed, these are quoted as equally spaced and includes one cold start.

For larger inertias and / or greater frequency of starting [please refer to TECO](#).

Starts Per Hour (Based on Maximum Load Inertia)

Pole	Frame Size					
	80 - 112	132 - 160	180 - 200	225 - 250	280	315M
2	12	10	8	5	3	3
4	22	20	16	10	6	4
6	28	25	20	12	8	6

Maximum Allowable Load Inertia

kW	Load Inertia							
	GD ² Kg-m ²	WR ² Kg-m ²	GD ² Kg-m ²	WR ² Kg-m ²	GD ² Kg-m ²	WR ² Kg-m ²	GD ² Kg-m ²	WR ² Kg-m ²
	2 Pole		4 Pole		6 Pole		8 Pole	
0.75	0.325	0.081	1.41	0.353	3.65	0.913	7.54	1.89
1.1	0.440	0.110	2.09	0.523	5.60	1.40	11.0	2.74
1.5	0.580	0.145	2.68	0.670	7.30	1.83	14.6	3.65
2.2	0.850	0.213	4.14	1.04	10.7	2.68	21.2	5.29
3	1.12	0.280	5.35	1.34	14.0	3.50	27.9	6.97
4	1.53	0.383	7.23	1.81	19.0	4.75	38.0	9.51
5.5	2.02	0.505	9.49	2.37	25.3	6.33	50.6	12.7
7.5	2.68	0.670	12.4	3.10	33.3	8.34	66.4	16.6
11	3.89	0.973	18.3	4.57	48.7	12.2	97.3	24.3
15	5.11	1.28	24.1	6.02	63.8	15.9	127	31.8
18.5	6.20	1.55	29.7	7.42	78.8	19.7	157	39.2
22	7.54	1.89	35.1	8.76	93.5	23.4	187	46.8
30	9.73	2.43	46.0	11.5	122	30.5	245	61.2
37	11.9	2.98	56.5	14.1	151	37.8	302	75.5
45	14.1	3.53	66.9	16.7	179	44.8	358	89.5
55	17.3	4.32	82.2	20.6	220	55.0	441	110
75	22.4	5.60	107	26.8	187	46.8	577	144
90	27.5	6.88	132	33.0	353	88.2	710	178
110	32.3	8.08	156	39.0	418	105	*	*
132	36.5	9.13	176	44.0	481	120	*	*
150	41.8	10.5	202	50.5	*	*	*	*
185	51.1	12.8	247	61.8	*	*	*	*

Notes: * For larger sizes please [refer to TECO](#).

Thermal Protection

The various types of thermal protection devices are described as below. Whilst these devices provide excellent thermal protection they may not fully protect against some transient conditions.

Additional set(s) of these protection devices can be provided with a lower temperature rating which can be utilized as an alarm function. Higher temperature ratings can be supplied for higher trip temperatures, however care should be taken to ensure the temperature rating of the insulation class is not compromised.

Thermistors

Thermistors, thermo-variable resistors and have a positive temperature co-efficient (PTC). Three thermistors are fitted to the end-windings (one per phase), which are connected in series. The standard TECO thermistors have a trip temperature of 160°C @ 1000 ohms (3000 ohms total, 3 thermistors, one per phase).

Thermistors are sensors that require connection to a control relay (this relay is not supplied by TECO).

The leads normally are terminated in the main terminal box with an auxiliary terminal box available if specified.

Temperature vs. Resistance Diagram

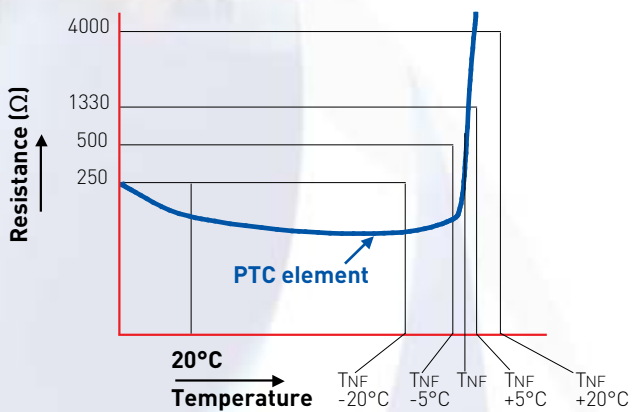

Connection Lead Colour Coding

Trip Temperature (°C)	Lead Wire Colours	
90	GREEN	GREEN
100	RED	RED
110	BROWN	BROWN
120	GREY	GREY
130	BLUE	BLUE
140	WHITE	BLUE
150	BLACK	BLACK
160	BLUE	RED

Thermistors and / or RTD's should not be Meggered or tested at a voltage above 2.5 volts.

Typical Thermistor Nameplates

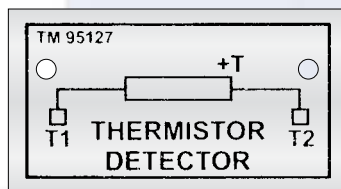

Resistance Temperature Detectors (RTDs)

An RTD, Resistance Temperature Detector, is a device that provides a change in resistance value in relationship to temperature.

This change is of a linear nature thereby providing the ability to accurately monitor the motor operating temperatures when connected to an appropriate relay.

The most commonly used RTD is the platinum type which has a nominal resistance of 100ohms @ 0°C (PT100) and is of the 3 wire type (other RTD types available on application).

When fitted the RTD leads are terminated to an auxiliary terminal box (it is recommended that external wiring to this box be of the screened copper conductor type to prevent any electromagnetic interference).

- Winding RTDs can be provided within the windings, one per phase or more as required.
- Bearing RTDs can be provided if required. The RTD element is located in a stainless steel metal probe and is mounted within a bearing thermowell.

“3 wire” RTD circuit

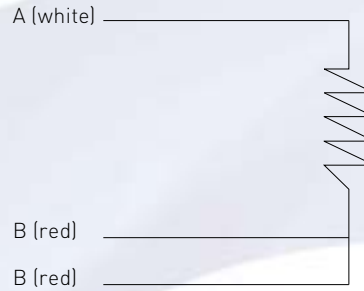

Table for Platinum Resistance Elements (Resistance in Ohms vs. Temperature) e.g. 19°C = 107.40 Ohms

°C	0	1	2	3	4	5	6	7	8	9
0	100.00	100.39	100.78	101.17	101.56	101.95	102.34	102.73	103.12	103.51
10	103.90	104.29	104.68	105.07	105.46	105.85	106.24	106.63	107.02	107.40
20	107.79	108.18	108.57	108.96	109.35	109.73	110.12	110.51	110.90	111.28
30	111.67	112.06	112.45	112.83	113.22	113.61	113.99	114.38	114.77	115.15
40	115.54	115.93	116.31	116.70	117.08	117.47	117.85	118.24	118.62	119.01
50	119.40	119.78	120.16	120.55	120.93	121.32	121.70	122.09	122.47	122.86
60	123.24	123.62	124.01	124.39	124.77	125.16	125.54	125.92	126.31	126.69
70	127.07	127.45	127.84	128.22	128.60	128.98	129.37	129.75	130.13	130.51
80	130.89	131.27	131.66	132.04	132.42	132.80	133.18	133.56	133.94	134.32
90	134.70	135.08	135.46	135.84	136.22	136.60	136.98	137.36	137.74	138.12
100	138.50	138.88	139.26	139.64	140.02	140.39	140.77	141.15	141.53	141.91
110	142.29	142.66	143.04	143.42	143.80	144.17	144.55	144.93	145.31	145.68
120	146.06	146.44	146.81	147.19	147.57	147.94	148.32	148.70	149.07	149.45
130	149.82	150.20	150.57	150.95	151.33	151.70	152.08	152.45	152.83	153.20
140	153.58	153.95	154.32	154.70	155.07	155.45	155.82	156.19	156.57	156.94
150	157.31	157.69	158.06	158.43	158.81	159.18	159.55	159.93	160.30	160.67
160	161.04	161.42	161.79	162.16	162.53	162.90	163.27	163.65	164.02	164.39
170	164.76	165.13	165.50	165.87	166.24	166.61	166.98	167.35	167.72	168.09
180	168.46	168.83	169.20	169.57	169.94	170.31	170.68	171.05	171.42	171.79
190	172.16	172.53	172.90	173.26	173.63	174.00	174.37	174.74	175.10	175.47
200	175.84	176.21	176.57	176.94	177.31	177.68	178.04	178.41	178.78	179.14

Recommend Temperature Settings for RTDs

Device	Type	Location	Alarm	Trip
RTD	Platinum 100 Ohms @ 0°C	Winding	140°C	150°C
RTD	Platinum 100 Ohms @ 0°C	DE & NDE Bearing	95°C	100°C

Note: Higher setting acceptable based on Class H insulation, [refer to TECO](#).

Tolerances for Electromechanical Characteristics

AS60034-1 Specifies Standard Tolerances for Electromechanical Characteristics (Squirrel Cage Induction Motors)

Quantity	Tolerance
Efficiency $P \leq 150$ kW	-15% (1- η)
Efficiency $P > 150$ kW	-10% (1- η)
Power factor (Cos ϕ)	-1/6 (1-cos ϕ) min. 0.02, max. 0.07
Slip $P < 1$ kW	$\pm 30\%$ of the slip
Slip $P \geq 1$ kW	$\pm 20\%$ of the slip
Starting torque	-15%, +25% of the torque
Starting current	+20% of the current
Pull-up torque	-15% of the torque
Break down torque	-10% of the torque >1.5 full load torque

AS1359.10 Dimensional Tolerances

Shaft Height

Dimension "H"

Frame Size	Tolerance	Tolerance (mm)
63 to 250		+ 0
		- 0.5
280 to 450		+ 0
		- 1

Shaft

Dimension "D".

D	Tolerance	Tolerance (mm)
14	j6	+ 0.008
		- 0.003
19 to 28	j6	+ 0.009
		- 0.004
32 to 48	k6	+ 0.018
		+ 0.002
55 to 80	m6	+ 0.030
		+ 0.011
85 to 120	m6	+ 0.035
		+ 0.013
125	m6	+ 0.040
		+ 0.015

Flange

Dimension "N"

N	Tolerance	Tolerance (mm)
110	h7	+ 0
		- 0.035
130 & 180	h7	+ 0
		- 0.040
230 & 250	h7	+ 0
		- 0.046
300	h7	+ 0
		- 0.052
350	h7	+ 0
		- 0.057
450	h7	+ 0
		- 0.063
550	h7	+ 0
		- 0.070

C Face

Dimension "N"

N	Tolerance	Tolerance (mm)
60 to 80	h7	+ 0
		- 0.030
95 & 110	h7	+ 0
		- 0.035
130	h7	+ 0
		- 0.040

Variable Speed Drives (VVVF)

The output of Variable Voltage Variable Frequency (VVVF) Drives is not purely sinusoidal. This causes higher voltage stresses within the windings and increases the losses, vibration, and noise of the motor. The Loadability Curve and Maximum Safe Speed are as below, this graph should be used as a guide only. Further consultation with TECO may be required for arduous critical speed and load duties.

Typical Motor Loadability Curve

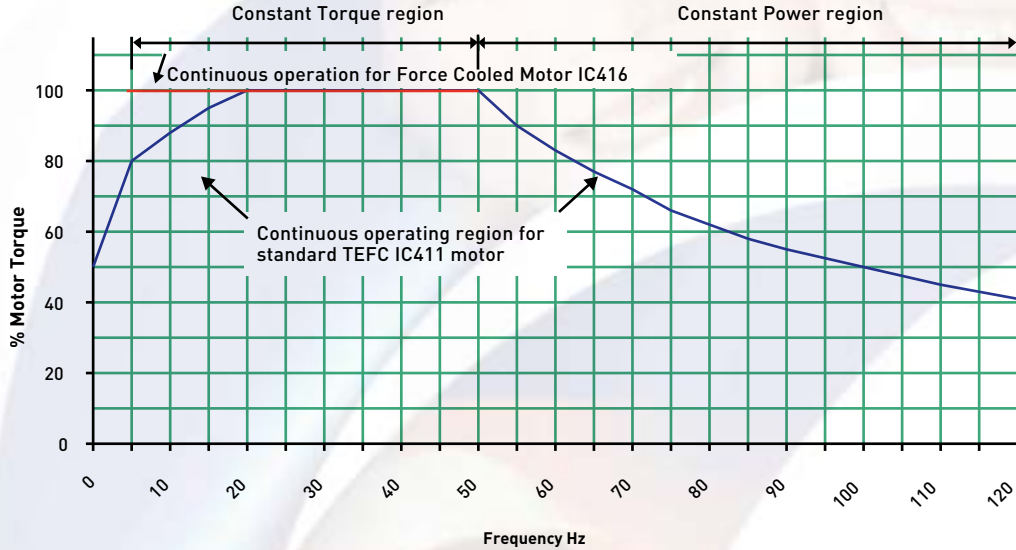

- Notes:**
1. Installation: to follow the guidelines detailed in "AS60034-17:2006 Cage induction motors when fed from converters - Application guide"
 2. Maximum safe operating speed to follow AS60034-1, Table 17

For variable torque loads (centrifugal pumps and fans) for speeds between 5-50 Hz derating is not normally required. Outside of this range [please check with TECO](#) for motor suitability.

Typical variable and constant torque load curves are shown below.

Speed vs. Torque Curves (assuming load torque @ 100% speed = motor full load torque)

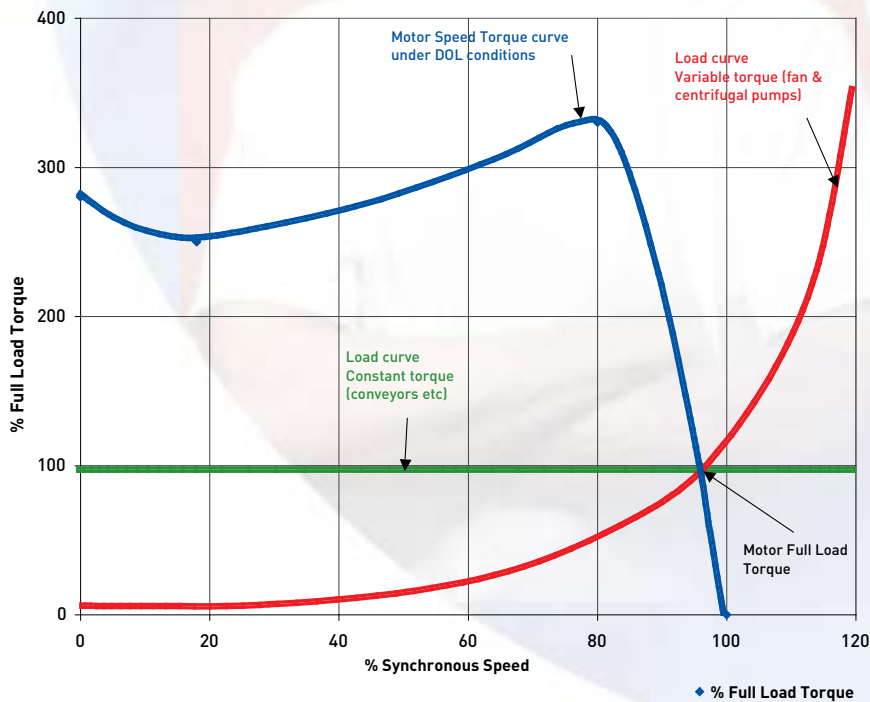

Variable Speed Drives (VVVF) *continued*

Maximum Safe Operating Speeds (AS60034-1 Table 17)

Frame Number	2 Pole	4 Pole	6 Pole
≤ 112	5200	3600	2400
132 ~ 180	4500	2700	2400
200	4500	2300	1800
225 ~ 315	3600	2300	1800

Note: Motors are balanced to 60 Hz speed. If motor operation is above 60 Hz special balance may be required ([please refer to TECO](#)).

Motor Synchronous Speed vs. Frequency

Motor Synchronous Speed vs. Frequency																									
Frequency (Hz)	0	5	10	15	20	25	30	35	40	45	50	55	60	65	70	75	80	85	90	95	100	105	110	115	120
2 Pole RPM	0	300	600	900	1200	1500	1800	2100	2400	2700	3000	3300	3600	3900	4200	4500	4800	5100	5400	5700	6000	6300	6600	6900	7200
4 Pole RPM	0	150	300	450	600	750	900	1050	1200	1350	1500	1650	1800	1950	2100	2250	2400	2550	2700	2850	3000	3150	3300	3450	3600
6 Pole RPM	0	100	200	300	400	500	600	700	800	900	1000	1100	1200	1300	1400	1500	1600	1700	1800	1900	2000	2100	2200	2300	2400
8 Pole RPM	0	75	150	225	300	375	450	525	600	675	750	825	900	975	1050	1125	1200	1275	1350	1425	1500	1575	1650	1725	1800

Cage Induction Motors when Fed from Variable Speed Drives

TECO motors follow the guidelines laid down in AS60034-17: "Cage Induction motors when fed from converters - Application guide".

Certain applications, installations and site condition may cause some damage to motors if they are not correctly installed. AS60034-17 has details on installation of Cage Motors and Variable Speed Drives.

Supply Systems ≤ 500 Volts

On TEFC motors frame size D280 and larger TECO can offer the option of a rotor groundary brush at the drive end in order to aid in reducing the effects of Electro Discharge Machining (EDM) on motor bearings, which can be prevalent in some cases.

On larger motors, frame size D315 and above, we recommend the additional option on an insulated bearing at the non drive end to eliminate shaft current and also assist in reduction of EDM through the motor bearings.

Both of these options can also be offered on smaller motors.

Supply systems in excess of 500 Volts and Open Drip motors frame size C280 and larger may require special consideration, please refer to TECO.

TECO Random wound stock motors are built in accordance to stress Category B per IEC60034-18-41.

The tested capability for PDIV (Partial Discharge Inception Voltage) for TECO stock motors up to 500Volts –

- Phase to Ground ≥ 1,843Volts@ rise time of ≥ 0.3us
- Phase to Phase ≥ 2,633Volts@ rise time of ≥ 0.3us

"Rotor Groundary Brush" fitted to D315 frame motor



Typical "VSD Ready" Large Frame Size Motor

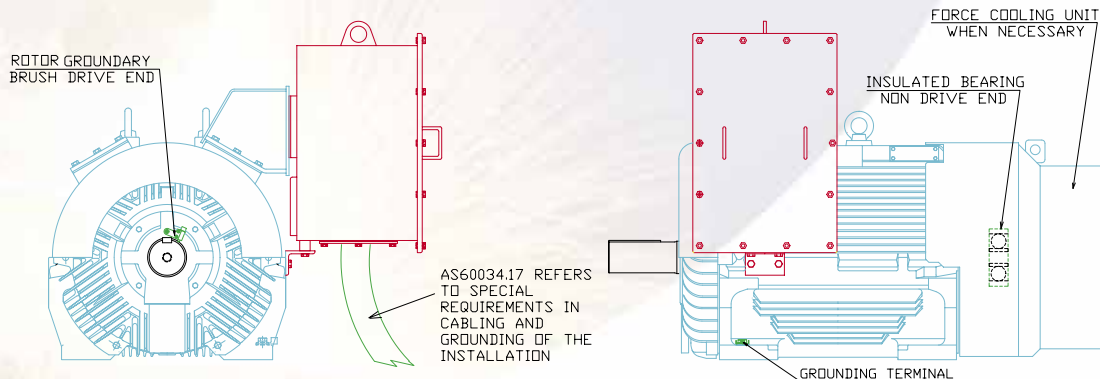

Voltage and Frequency Variations during Operation - AS60034-1

For a.c. motors rated for use on a power supply of fixed frequency supplied from an a.c. generator (whether local or via a supply network), combinations of voltage variation and frequency variation are classified as being either Zone A or Zone B, in accordance with the figure right.

A machine shall be capable of performing its primary function continuously within zone A, but need not comply fully with its performance at rated voltage and frequency and may exhibit some deviations. Temperature rises may be higher than at rated voltage and frequency.

A machine shall be capable of performing its primary function within zone B, but may exhibit greater deviations from its performance at rated Voltage and frequency than in zone A. Temperature rises may be higher than at rated voltage and frequency and most likely will be higher than those in zone A.

Voltage and Frequency Limits for Motors

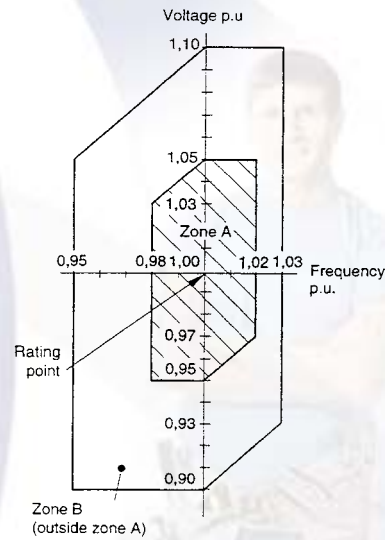

Voltage Variation, Effect on Performance

The characteristics of motors will of course vary with a corresponding variation in voltage of $\pm 10\%$ around the nominal value.

An approximation of these variations is given in the table below.

	Voltage Variation in %				
	$U_N - 10\%$	$U_N - 5\%$	U_N	$U_N + 5\%$	$U_N + 10\%$
Torque curve	0.81	0.9	1	1.1	1.21
Slip	1.23	1.11	1	0.91	0.83
Rated current	1.1	1.05	1	0.98	0.98
Rated efficiency	0.97	0.98	1	1	0.98
Rated power factor ($\cos\phi$)	1.03	1.02	1	0.97	0.94
Starting current	0.9	0.95	1	1.05	1.1
Nominal temperature rise	1.18	1.05	1	1.00	1.1
P (Watt) no-load	0.85	0.92	1	1.12	1.25
Q (reactive V A) no-load	0.81	0.9	1	1.1	1.21

Other Mains Supply

The TECO Australia 380-415 Volt 3-Phase 50 Hz stock motors up to frame size D315M are also suitable for re-nameplating to 440 Volt 50 Hz or 400-480 Volt 60 Hz without the need for derating. Performance details are [available on request](#).

Some world supply systems are given below. Site supply details should be checked to confirm.

World 3-Phase Voltage-Frequency

Country	Voltage	Frequency	Country	Voltage	Frequency	Country	Voltage	Frequency
Taiwan	380	60	Japan	200	50/60	* England	415*	50
Singapore	400	50	Philippines	460	60	* Germany	380*	50
Malaysia	415	50	India	400	50	Italy	380*	50
Indonesia	380	50	Korea	380	60	Spain	380*	50
Thailand	380	50	Vietnam	380	50	Netherlands	380*	50
China	380	50	USA	460	60	Australia	415	50
Hong Kong	346	50	Canada	460 or 565	60	South Africa	380	50
						Saudi Arabia	380	50

Note: * EU are harmonising voltage to 400 Volt 50 Hz

The TECO Group of Companies comprises a diverse range of six major sectors, including:

Industrial Product and System (IPS)



Low & high voltage motors, Mechatronic Components, Power Electric & System Control, Infrastructure Projects.

Some other TECO IPS products:

- 3-Phase Induction Motors
- 3-Phase Open Drip Proof Motors
- Brake Motors
- Crane Motors
- Cooling Tower Motors
- Eddy Current Motors
- Generators
- Hazardous Areas Motors
- High Efficiency Motors
- High Voltage Motors
- Induction Generators
- Mill use Induction Motors
- Multi-speed Motors
- Single Phase Motors
- Slip Ring Motors
- Smoke Spill Motors
- Synchronous Motors
- Vertical Hollow Shaft Motors
- Variable Speed Drives
- AC-DC Motor Controls

Consumer Appliance and Service



Air Conditioners, LCD Televisions, Household Appliances, Hospitality Restaurants.

IT and Optronics Product Sector



Nanotechnology, Optronics, Creative Sensor, Image Systems.

Telecommunications and Service



Mobile/Voice/Data Communications, Broadband Wireless and Opto-Electronics Technology.

Information System and Service



Smart Cards, e-Purse/ e-Commerce, IT Services, Biotech Department.

Investment and Holding



High Speed Railways, Software & Technology Parks, Venture Capital & Investment.

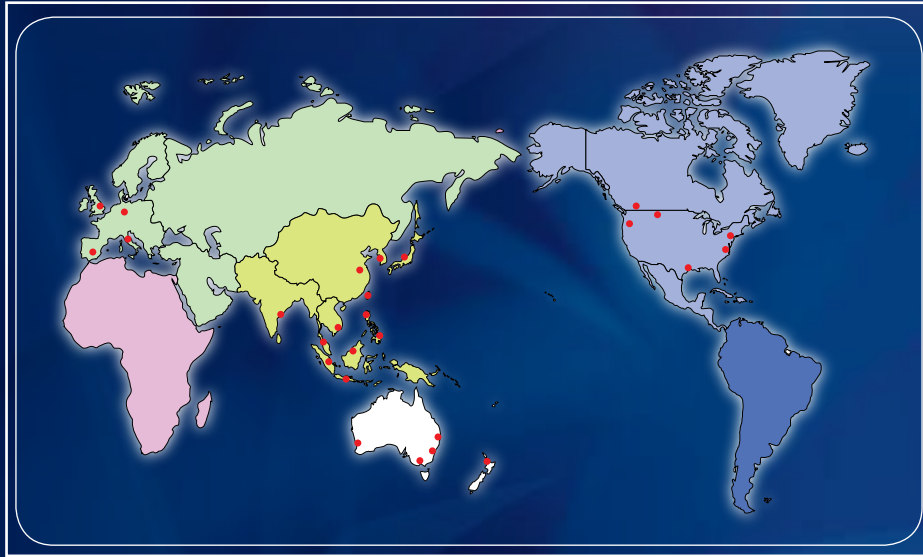

AUSTRALIA & NEW ZEALAND



Head Office, Sydney

TECO Australia Pty Ltd
 335-337 Woodpark Road,
 Smithfield NSW 2164
 Tel: 02 9765 8118
 Fax: 02 9604 9330



Melbourne

TECO Australia Pty Ltd
 16 Longstaff Road,
 Bayswater VIC 3153
 Tel: 03 9720 4411
 Fax: 03 9720 5355



Brisbane

TECO Australia Pty Ltd
 50 Murdoch Circuit,
 Acacia Ridge QLD 4110
 Tel: 07 3373 9600
 Fax: 07 3373 9699



Perth

TECO Australia Pty Ltd
 28 Belgravia Street,
 Belmont WA 6104
 Tel: 08 9479 4879
 Fax: 08 9478 3876



New Zealand

TECO New Zealand Ltd
 Unit 3, 477 Great South Road,
 Penrose, Auckland
 Tel: 64 9-526 8480
 Fax: 64 9-526 8484
 sales@teco.co.nz

Distributed by:

www.teco.com.au emd@teco.com.au