

Product data sheet

Variable speed drive E510-202-H1FN4S-IP66/NEMA 4X, 1.5KW, 2HP, 200-240V

Features

- Advanced sensorless vector control
- Directly frequency setting and simple to adjust speed
- Integrated safety stop and fire mode functions
- Built-in PID controller and PLC function
- Built-in Modbus Communication(RS485)

Component name		E510
Horse Power(HP)		2
Suitable Motor Capacity Capacity(KW)		1.5
Rated Output Current(A)		7.5
Rated Capacity(KVA)		2.9
Input Voltage Range(V)		Single-phase 200~ 240V, 50/60Hz
Allowable Voltage Fluctuation		-15%~ +10%
Output Voltage range(V)		Three-phase 0~240V
Input current(A)		16
Allowable Momentary Power Loss Time(Sec.)		2.0
Enclosure		IP 66/NEMA 4X
Control Mode		V/F Control, Vector Control
Frequency	Output Frequency	0.01~599.00Hz
	Starting Torque	150%/3Hz(V/F),150%/1Hz(Vector)
	Speed Control Ratio	1:50
	Setting Resolution	Digital input: 0.01Hz
		Analog input:0.06Hz/60Hz
	Setting	Keypad: Set directly with ▲ ▼ keys or the VR on the keypad External Input Terminals: AI1(0/2~10V), AI2(0/4~20mA)input Multifunction input up/down function(Group3) Setting frequency by communication method.
Frequency Limit	Lower and upper frequency limits 3 skip frequency settings.	
Run	Operation Set	Keypad run, stop button
		External terminals: Multi- operation-mode(2 or3 wire selection) Jog operation
		Run signal by communication method.
Main Control Features	V/F Curve Setting	18 fixed curves and one customized curve
	Carrier Frequency	1~16KHz
	Acceleration and Deceleration Control	2 sections of acceleration /deceleration time setting(0.1~ 3600.0 Sec) 4 sections of S curve setting
	Multifunction Input	29 functions (refer to group3 in the manual)

Product data sheet

	Multifunction Output	21 functions (refer to group3 in the manual)
	Multifunction Analog Output	5 functions (refer to group4 in the manual)
	Main Features	Overload Detection,16 preset speeds, Auto-run, Acc/Dec Switch (2 Stages),Main/Alt run Command select, Main/Alt Frequency Command select, PID control, Torque boost, V/F start Frequency, Slip frequency, Fault reset
Display	LED	Display :parameter / parameter value / frequency / line speed / DC voltage / output voltage / output current / PID feedback / input and output terminal status / Heat sink temperature / Program Version / Fault Log
	LED Status Indicator	Run / Stop / Forward / Reverse ,and etc.
Protective Functions	Overload Protection	The relays to protect the motor and the inverter. (150%/1min)
	Over Voltage	200V class :>410V , 400V class:>820V
	Under Voltage	200V class :<190V , 400V class:<380V
	Momentary Power Loss Restart	Inverter auto-restart after a momentary power loss.
	Stall Prevention	Stall prevention for Acceleration/ Deceleration/ Operation.
	Short-circuit Output Terminal	Electronic Circuit Protection
	Grounding Fault	Electronic Circuit Protection
	Other Protection Functions	Protection for overheating of heat sink, The carrier frequency decreasing with the temperature function, fault output, reverse prohibit, prohibit for direct start after power up and error recovery ,parameter lock up
	brake transistor	Built in
Communication control	Standard built-in RS485 communication (Modbus), One to one or One to many control	
Environment	Operating temperature	IP20/NEMA 1 Type: -10 ~ 50°C (without stick on type dust cover.) -10 ~ 40°C (with stick on type dust cover.) IP66/NEMA 4X Type : -10~50°C
	Storage temperature	-20~ 60°C
	Humidity	95% RH or less (no condensation) (Compliance with IEC 60068 -2-78)
	Shock	20Hz or less 1G(9.8m/s ²)20~50Hz 0.6G(5.88m/s ²) (Compliance with IEC 60068 -2-6)
	Enclosure	IP20/NEMA1 and IP66/NEMA4X

Product data sheet

External View

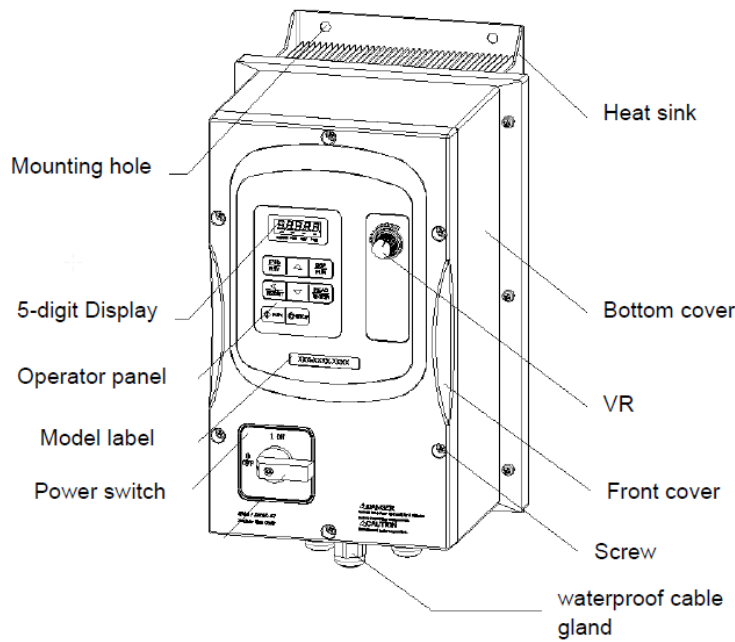

(IP66/NEMA 4X With/Without VR and switches depending on the model)

Inverter De-rating Based on Temperature

Curves below show the applicable output current de-rate due to setting of carrier frequency and the ambient operating temperatures of 40 and 50 °C .

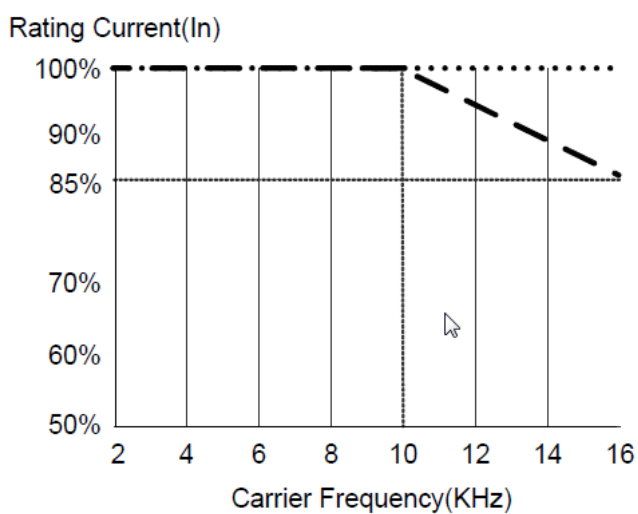

Notes:

..... De-rate curve for ambient temperature of 40 °C

----- De-rate curve for ambient temperature of 50 °C

Product data sheet

General Wiring Diagram(single phase)

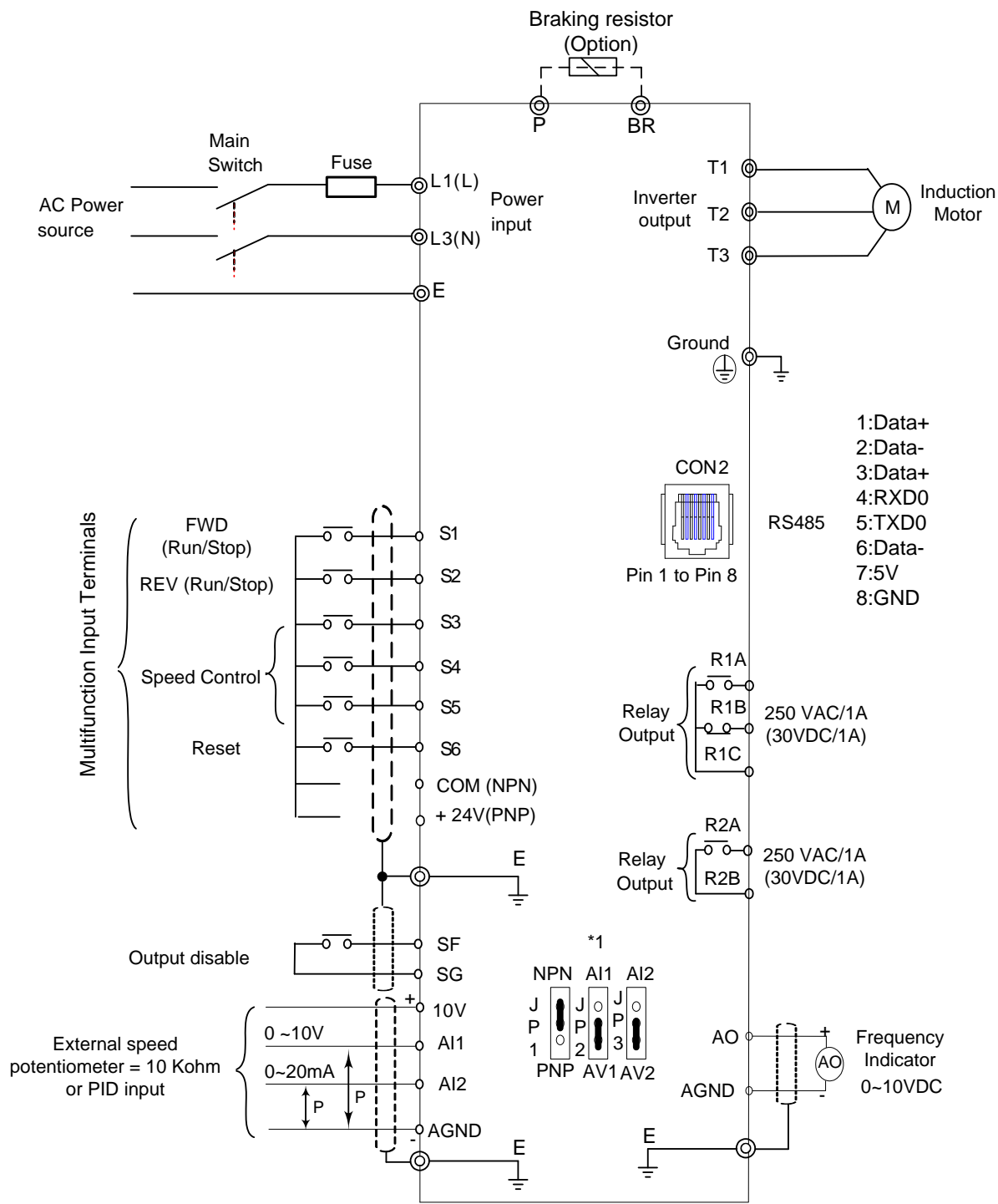

- 1:Data+
- 2:Data-
- 3:Data+
- 4:RXD0
- 5:TXD0
- 6:Data-
- 7:5V
- 8:GND

Indicates shield wire P Indicates twisted-pair shield wire

Shows main circuit Shows control circuit

*1: JP1:NPN/PNP selection, JP2:AI1 0~10V/0~20mA selection, JP3:AI2 0~10V/0~20mA selection

Product data sheet

Dimensions

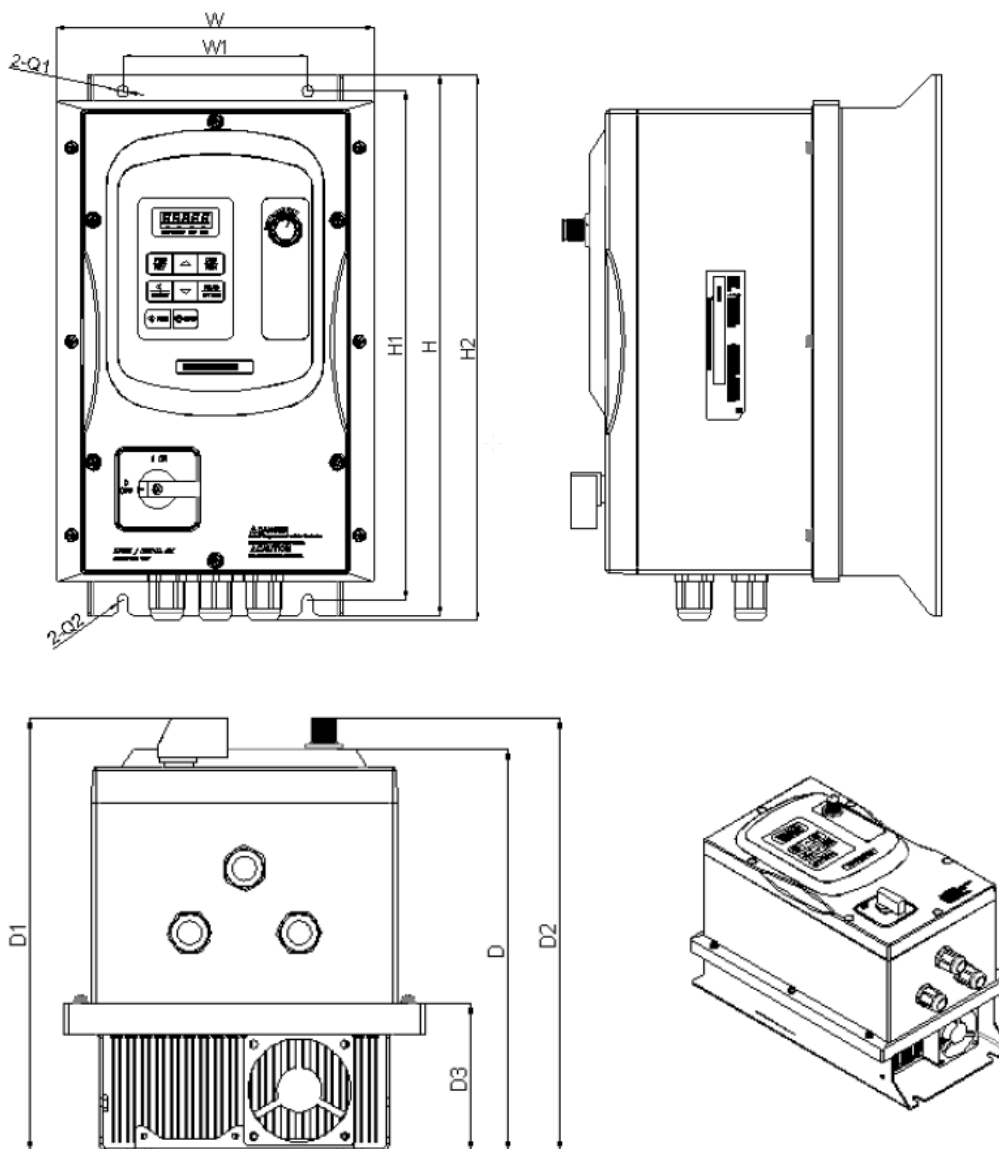

Inverter model	Dimensions in mm (inch)						NW in kg
	W	W1	H	H1	H2	D	
E510-202-H1FN4S	198 (7.80)	115 (4.53)	335 (13.19)	315 (12.40)	337.9 (13.30)	218.4 (8.60)	5.98
	D1	D2	D3	Q1	Q2		
	235.2 (9.26)	235.2 (9.26)	79.8 (3.14)	7 (0.28)	7 (0.28)		

Product data sheet

Installation Spaces

Provide sufficient air circulation space for cooling as shown below. Install the inverter on surfaces that provide good heat dissipation.

Single unit installation

Install the inverter vertically to obtain effective cooling

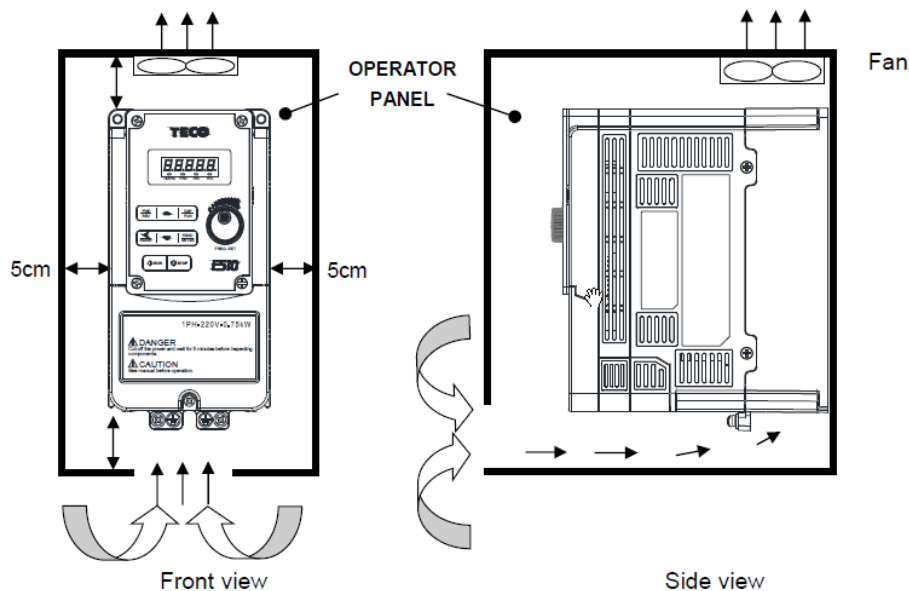

Side by side installation

Provide the necessary physical space and cooling based on the ambient temperature and the heat loss in the panel

