

## Product data sheet

Variable speed drive F510-4060 -C3FN4-IP55, 45KW, 60HP, 380-460V

### Features

- Pump Cascade Control
- Hardware Safe Torque Off Function
- Conformity To Global Standards
- Communication protocols include BACnet, Metasys and Modbus
- Fire Override Mode
- Permanent-Magnet Motor Control Technology
- RTC Function/simple PLC
- Automatic Energy Saving Function

|                              |                                 |  |
|------------------------------|---------------------------------|--|
| Component name               |                                 | F510   |
| Inverter Capacity(HP)        |                                 | 60   |
| Output Rated                 | Rated Output Capacity(KVA)      | 67   |
|                              | Rated Output Current(A)         | 88   |
|                              | Maximum Applicable Motor (HP)   | 60   |
|                              | (KW)                            | 45   |
|                              | Maximum Output Voltage(V)       | Three Phase, 380-480V  |
| Maximum Output Frequency(Hz) |                                 | Based on parameter setting 0.1~400.0Hz   |
| Input Power                  | Rated Voltage, Frequency        | Three Phase, 380V-480V, 50/60Hz  |
|                              | Allowable Voltage Fluctuation   | -15% ~ +10%  |
|                              | Allowable Frequency Fluctuation | ±5%  |
| Control characteristics      | Display                         | LCD keypad(HOA LCD keypad option)  |
|                              | Control Modes                   | V/F, SLV, PMSLV with Space Vector PWM Mode   |
|                              | Output Frequency                | 0.1Hz~400.0Hz  |
|                              | Frequency Accuracy              | Digital references: ±0.01%(-10~ +40 °C),<br>Analog references: ±0.1%(25 °C ± 10 °C), |
|                              | Speed Control Accuracy          | ±0.5%(sensorless Vector Control Mode) *1   |
|                              | Frequency setting Resolution    | Digital references: 0.01Hz, Analog references:0.06Hz/60Hz                            |
|                              | Output Frequency Resolution     | 0.01Hz   |
|                              | Overload Tolerance              | 120%/1min  |
| Frequency Setting Signal     |                                 | DC 0~10V / 0~ 20mA or 4~ 20mA  |

## Product data sheet

|                           |  |  |
|---------------------------|--|--|
| Control characteristics   | Acceleration/Deceleration Time   | 0.0~ 6000.0 second(separately set acceleration and deceleration time)  |
|                           | Voltage/Frequency Characteristics  | Can arbitrarily set V/F curve based on parameters  |
|                           | Braking Torque   | About 20%  |
|                           | Main Control Functions   | Auto tuning, Soft-PWM, Over-voltage protection, Dynamic braking, Speed search, Momentary power loss restart, 2 sets of PID control, Slide difference Compensation, RS-485 communication standard, Simple PLC function, 2 sets of analog outputs, Safety switch   |
|                           | Other Functions  | Records of power on and operation time, 4 fault history records and latest fault record state, Energy-saving function, Phase loss protection, Smart braking, DC braking, Dwell , S curve acceleration and deceleration, Up/Down operation, Modbus, BACnet MS/TP and Metasys N2 communication protocol, Display of multi-engineering unit, Local/ Remote switch, SINK/SOURCE input interface selection, User parameter settings |
| Protection Functions      | Stall Protection   | Current level can be set (in acceleration or constant speed; it can be set separately. In deceleration, it can be set with or without protection)  |
|                           | Over Current(OC) and Output Short-circuit(SC) Protection                     | It stops when the output current exceeds 160% of the inverter rated current  |
|                           | Inverter Overload Protection(OL2)  | Inverter will be stopped when the output higher than 120% rated current for 1min, carrier frequency is 2~4KHZ *2   |
|                           | Motor Overload Protection(OL1)   | Electrical overload protection curve   |
|                           | Over Voltage Protection(OV)  | If the main circuit DC voltage rises over 820V (400V class), the motor stops running.  |
|                           | Under Voltage Protection(UV)   | If the main circuit DC voltage falls below 380V (400V class), the motor stops running  |
|                           | Momentary power loss restart   | Power loss exceeds 15ms. You can set the function of momentary power loss restart up to 2sec   |
|                           | Overheat Protection(OH)  | Thermistor sensor on heatsink  |
|                           | Ground Fault Protection(GF)  | Protection by current detection circuit  |
|                           | Charge Indicator   | When main circuit Dc voltage $\geq 50V$ , the CHARGE LED is on   |
|                           | Output Phase Loss Protection(OPL)  | If the OPL function acts, the motor stops rotation automatically   |
| Environment Specification | Location   | Indoor (protected from corrosive gases and dust)   |
|                           | Ambient Temperature  | -10~+40°C (IP20/NEMA1 and IP55/NEMA12),<br>-10~+50°C (IP00); with de-rating, its maximum operation temperature is 60°C   |
|                           | Storage Temperature  | -20~+70°C  |
|                           | Humidity   | 95%RH or less (no condensation)  |
|                           | Altitude and Vibration   | Altitude of 1000 meters or lower, 1.0G, in compliance with IEC 60068-2-6   |
| Communication Function    | Built-in RS-485 as standard (Modbus protocol with RJ45 / BACnet/ Metasys N2) |  |
| PLC Function              | Built-in   |  |

## Product data sheet

|                                     |   |  |
|-------------------------------------|---|--|
| Electromagnetic Interference(EMI)   | Meet EN61800-3 standard, IP20 400V 75HP or below and IP55 400V 60HP can be built in |  |
| Electromagnetic Susceptibility(EMS) | Meet EN61800-3 standard   |  |
| Certification                       | CE  | Meet EN61800-3 (CE & RE) and EN61800-5-1 (LVD) |
|                                     | UL  | UL508C   |
| Option Card                         | 1 to 8 Pump card, HOA LCD keypad, Profibus card                                     |  |

### Notes:

1. Speed control accuracy will be influenced when the motor and installation condition are different
2. The default setting of carrier frequency is different from models

## External View

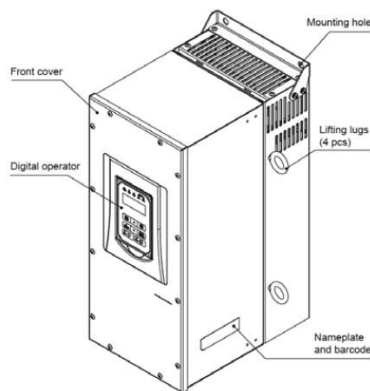

(Wall-mounted type, IEC IP55)

## Inverter De-rating Based on Temperature

| Rated Current Ratio | Temperature |
|---------------------|-------------|
| 100%                | 40°C        |
| 90%                 | 45°C        |
| 80%                 | 50°C        |
| 70%                 | 55°C        |
| 60%                 | 60°C        |

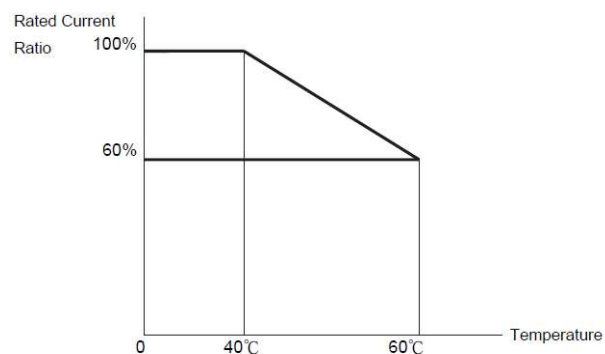

Note: User needs to adjust the inverter rated current depending on ambient temperature to ensure the appropriate industrial application

# Product data sheet

## General Wiring Diagram

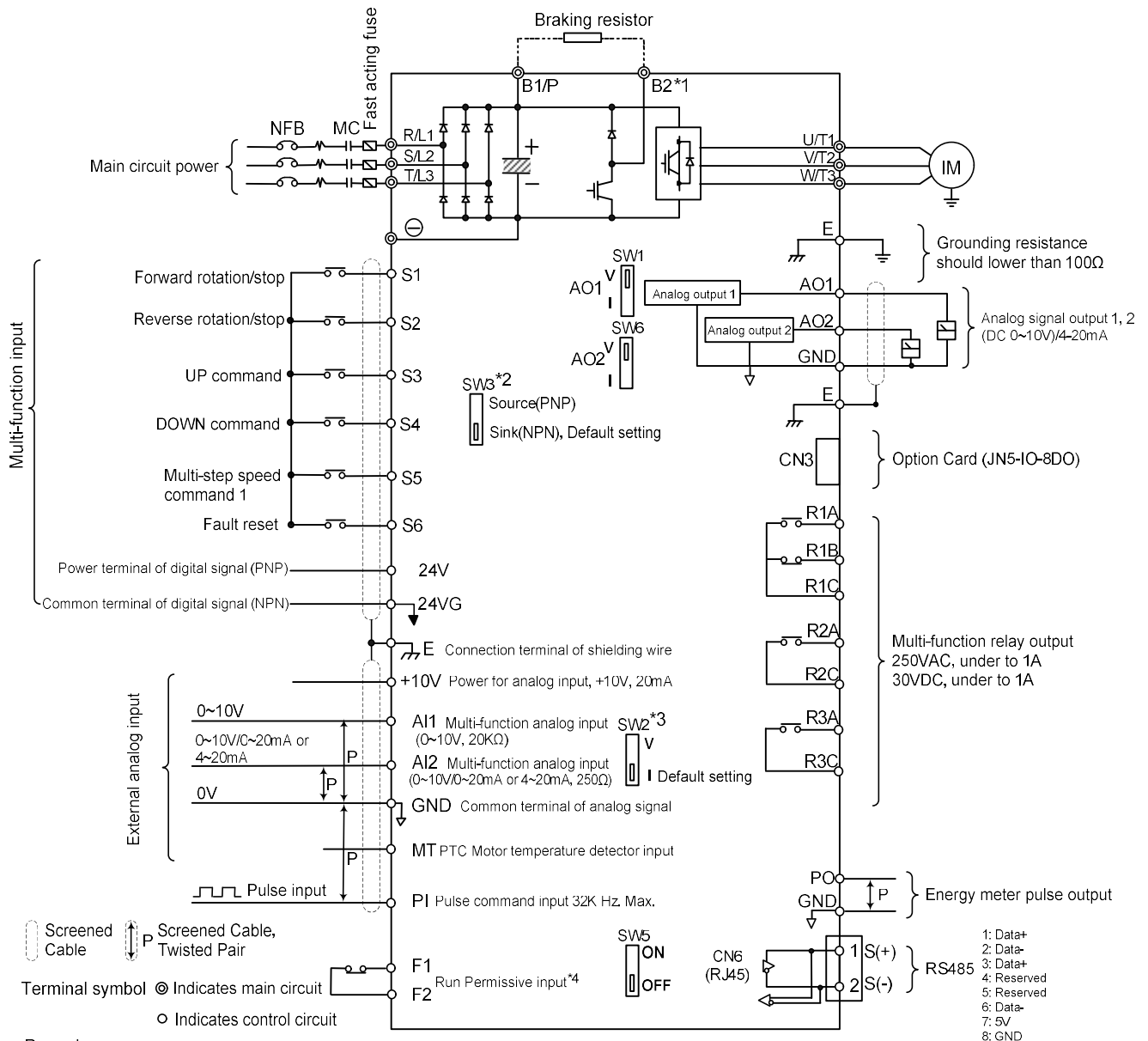

Multi-function input

External analog input

- 1: Data+
- 2: Data-
- 3: Data+
- 4: Reserved
- 5: Reserved
- 6: Data-
- 7: 5V
- 8: GND

# Product data sheet

## Dimensions

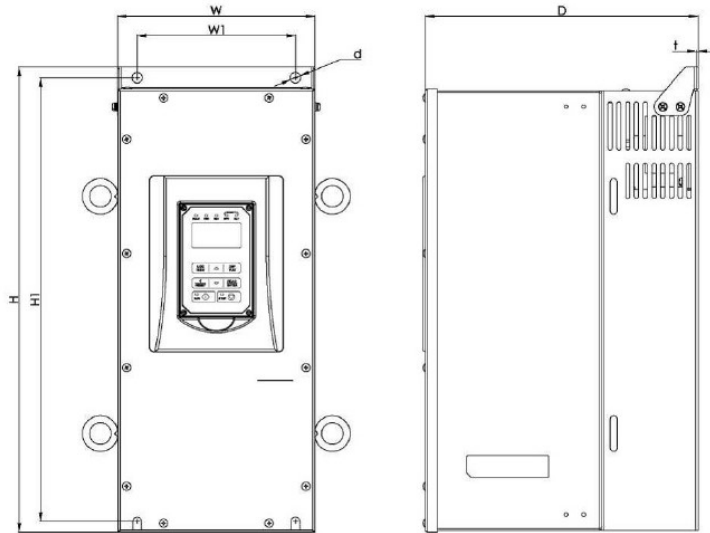

| Inverter model  | Dimensions in mm (inch) |                |                |                |                |               |     | d              | NW in kg(lbs) |
|-----------------|-------------------------|----------------|----------------|----------------|----------------|---------------|-----|----------------|---------------|
|                 | W                       | H              | D              | W1             | H1             | t             |     |                |               |
| F510-4060-C3FN4 | 326<br>(12.83)          | 695<br>(27.36) | 343<br>(13.50) | 276<br>(10.87) | 671<br>(26.42) | 2.3<br>(0.09) | M10 | 55<br>(121.25) |               |

## Installation Spaces

When installing the inverter, ensure that inverter is installed in upright position (vertical direction) and there is adequate space around the unit to allow normal heat dissipation as per the following figure.

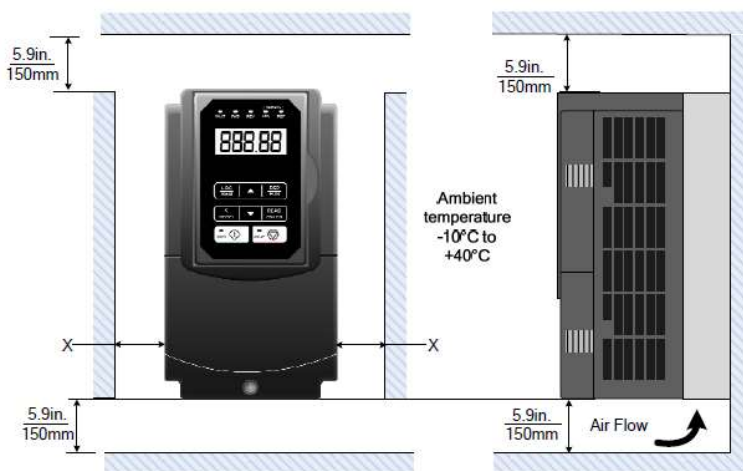

X = 1.18" (30mm) for inverter ratings up to 18.5kW  
 X = 1.96" (50mm) for inverter ratings 22kW or higher

**Important Note:** The inverter heatsink temperature can reach up to 90°C/ 194°F during operation; make sure to use insulation material rated for this temperature.