



TECO V33 AC drive



Instruction manual
English
Software version 4.3X

V33

INSTRUCTION MANUAL - ENGLISH

Software version 4.3X

Document number:

Edition: r3

Date of release: 30-01-2011

© Copyright the manufacturer of V33 2005 - 2011

The manufacturer retains the right to change specifications and illustrations in the text, without prior notification. The contents of this document may not be copied without the explicit permission of the manufacturer.

Safety Instructions

Instruction manual

Read this instruction manual before using the AC drive (Frequency converter).

The following symbols can appear in this manual. Always read these first before continuing:

NOTE: Additional information as an aid to avoid problems.



CAUTION!
Failure to follow these instructions can result in malfunction or damage to the AC drive.



WARNING!
Failure to follow these instructions can result in serious injury to the user in addition to serious damage to the AC drive.



HOT SURFACE!
Failure to follow these instructions can result in injury to the user.

Handling the AC drive

Installation, commissioning, demounting, taking measurements, etc. of or on the AC drive may only be carried out by personnel technically qualified for the task. The installation must be carried out in accordance with local standards.

Opening the AC drive



WARNING!
Always switch off the mains voltage before opening the AC drive and wait at least 7 minutes to allow the buffer capacitors to discharge.

Always take adequate precautions before opening the AC drive. Although the connections for the control signals and the switches are isolated from the main voltage, do not touch the control board when the AC drive is switched on.

Precautions to be taken with a connected motor

If work must be carried out on a connected motor or on the driven machine, the mains voltage must always be disconnected from the AC drive first. Wait at least 7 minutes before starting work.

Earthing

The AC drive must always be earthed via the mains safety earth connection.

Earth leakage current



CAUTION!

This AC drive has an earth leakage current which does exceed 3.5 mA AC. Therefore the minimum size of the protective earth conductor must comply with the local safety regulations for high leakage current equipment which means that according the standard IEC61800-5-1 the protective earth connection must be assured by one of following conditions:

1. Use a protective conductor with a cable cross-section of at least 10 mm² for copper (Cu) or 16 mm² for aluminium (Al).
 2. Use an additional PE wire, with the same cable cross-section as the used original PE and mains supply wiring.
-

Residual current device (RCD) compatibility

This product cause a DC current in the protective conductor. Where a residual current device (RCD) is used for protection in case of direct or indirect contact, only a Type B RCD is allowed on the supply side of this product. Use RCD of 300 mA minimum.

EMC Regulations

In order to comply with the EMC Directive, it is absolutely necessary to follow the installation instructions. All installation descriptions in this manual follow the EMC Directive.

Mains voltage selection

The AC drive may be ordered for use with the mains voltage range listed below.

JNVX48: 230-480 V
JNVX52: 440-525 V
JNVX69: 500-690 V

Voltage tests (Megger)

Do not carry out voltage tests (Megger) on the motor, before all the motor cables have been disconnected from the AC drive.

Condensation

If the AC drive is moved from a cold (storage) room to a room where it will be installed, condensation can occur. This can result in sensitive components becoming damp. Do not connect the mains voltage until all visible dampness has evaporated.

Incorrect connection

The AC drive is not protected against incorrect connection of the mains voltage, and in particular against connection of the mains voltage to the motor outlets U, V and W. The AC drive can be damaged in this way.

Power factor capacitors for improving

$\cos\phi$

Remove all capacitors from the motor and the motor outlet.

Precautions during Autoreset

When the automatic reset is active, the motor will restart automatically provided that the cause of the trip has been removed. If necessary take the appropriate precautions.

Transport

To avoid damage, keep the AC drive in its original packaging during transport. This packaging is specially designed to absorb shocks during transport.

IT Mains supply

The AC drives can be modified for an IT mains supply, (non-earthed neutral), please contact your supplier for details.

Heat warning



HOT SURFACE!

Be aware of specific parts on the AC drive having high temperature.

DC-link residual voltage



WARNING!

After switching off the mains supply, dangerous voltage can still be present in the AC drive. When opening the AC drive for installing and/or commissioning activities

wait at least 7 minutes. In case of malfunction a qualified technician should check the DC-link or wait for one hour before dismantling the AC drive for repair.

Contents

| | | | | |
|---|-----------|-----------|--|-----------|
| Safety Instructions | 1 | 4.6 | Connecting options | 28 |
| Contents | 3 | 5. | Getting Started..... | 29 |
| 1. Introduction..... | 5 | 5.1 | Connect the mains and motor cables | 29 |
| 1.1 Delivery and unpacking | 5 | 5.1.1 | Mains cables | 29 |
| 1.2 Using of the instruction manual | 5 | 5.1.2 | Motor cables..... | 29 |
| 1.3 Type code number..... | 5 | 5.2 | Using the function keys | 29 |
| 1.4 Standards | 6 | 5.3 | Remote control..... | 30 |
| 1.4.1 Product standard for EMC | 6 | 5.3.1 | Connect control cables | 30 |
| 1.5 Dismantling and scrapping..... | 7 | 5.3.2 | Switch on the mains | 30 |
| 1.5.1 Disposal of old electrical and electronic equipment .. | 7 | 5.3.3 | Set the Motor Data..... | 30 |
| 1.6 Glossary | 8 | 5.3.4 | Run the AC drive..... | 30 |
| 1.6.1 Abbreviations and symbols..... | 8 | 5.4 | Local control | 31 |
| 1.6.2 Definitions..... | 8 | 5.4.1 | Switch on the mains | 31 |
| 2. Mounting..... | 9 | 5.4.2 | Select manual control..... | 31 |
| 2.1 Lifting instructions..... | 9 | 5.4.3 | Set the Motor Data..... | 31 |
| 2.2 Stand-alone units | 10 | 5.4.4 | Enter a Reference Value..... | 31 |
| 2.2.1 Cooling | 10 | 5.4.5 | Run the AC drive..... | 31 |
| 2.2.2 Mounting schemes..... | 10 | 6. | Applications..... | 33 |
| 2.3 Cabinet mounting..... | 13 | 6.1 | Application overview | 33 |
| 2.3.1 Cooling | 13 | 6.1.1 | Cranes..... | 33 |
| 2.3.2 Recommended free space in front of cabinet | 13 | 6.1.2 | Crushers..... | 33 |
| 2.3.3 Mounting schemes..... | 14 | 7. | Main Features | 35 |
| 3. Installation | 15 | 7.1 | Parameter sets..... | 35 |
| 3.1 Before installation | 15 | 7.1.1 | One motor and one parameter set | 36 |
| 3.2 Cable connections for model 0003 to 0074 | 15 | 7.1.2 | One motor and two parameter sets..... | 36 |
| 3.2.1 Mains cables | 15 | 7.1.3 | Two motors and two parameter sets | 36 |
| 3.2.2 Motor cables..... | 16 | 7.1.4 | Autoreset at trip | 36 |
| 3.3 Connection of motor and mains cables for model 0090 and up..... | 18 | 7.1.5 | Reference priority..... | 36 |
| 3.3.1 Connection of mains and motor cables on IP20 modules..... | 19 | 7.1.6 | Preset references..... | 37 |
| 3.4 Cable specifications..... | 20 | 7.2 | Remote control functions | 37 |
| 3.5 Stripping lengths | 20 | 7.3 | Performing an Identification Run..... | 40 |
| 3.5.1 Dimension of cables and fuses..... | 21 | 7.4 | Using the Control Panel Memory..... | 40 |
| 3.5.2 Tightening torque for mains and motor cables..... | 21 | 7.5 | Load Monitor and Process Protection [400]..... | 41 |
| 3.6 Thermal protection on the motor | 21 | 7.5.1 | Load Monitor [410]..... | 41 |
| 3.7 Motors in parallel | 21 | 8. | EMC and Machine Directive..... | 43 |
| 4. Control Connections..... | 23 | 8.1 | EMC standards..... | 43 |
| 4.1 Control board..... | 23 | 8.2 | Stop categories and emergency stop | 43 |
| 4.2 Terminal connections | 24 | 9. | Operation via the Control Panel..... | 45 |
| 4.3 Inputs configuration with the switches..... | 24 | 9.1 | General | 45 |
| 4.4 Connection example | 25 | 9.2 | The control panel | 45 |
| 4.5 Connecting the Control Signals..... | 26 | 9.2.1 | The display..... | 45 |
| 4.5.1 Cables | 26 | 9.2.2 | Indications on the display..... | 46 |
| 4.5.2 Types of control signals | 27 | 9.2.3 | LED indicators | 46 |
| 4.5.3 Screening..... | 27 | 9.2.4 | Control keys..... | 47 |
| 4.5.4 Single-ended or double-ended connection? | 27 | 9.2.5 | The Toggle and Loc/Rem Key | 47 |
| 4.5.5 Current signals ((0)4-20 mA)..... | 28 | 9.2.6 | Function keys | 48 |
| 4.5.6 Twisted cables..... | 28 | 9.3 | The menu structure | 48 |
| | | 9.3.1 | The main menu | 49 |
| | | 9.4 | Programming during operation | 49 |
| | | 9.5 | Editing values in a menu | 49 |

| | | | | | |
|------------|--|-----------|--------------------|---|------------|
| 9.6 | Copy current parameter to all sets | 50 | 11.8 | View Trip Log [800] | 160 |
| 9.7 | Programming example..... | 50 | 11.8.1 | Trip Message log [810]..... | 160 |
| 10. | Serial communication | 51 | 11.8.2 | Trip Messages [820] - [890] | 161 |
| 10.1 | Modbus RTU | 51 | 11.8.3 | Reset Trip Log [8A0] | 162 |
| 10.2 | Parameter sets..... | 51 | 11.9 | System Data [900]..... | 162 |
| 10.3 | Motor data | 52 | 11.9.1 | VSD Data [920] | 162 |
| 10.4 | Start and stop commands..... | 52 | 12. | Troubleshooting, Diagnoses and Maintenance 165 | |
| 10.5 | Reference signal | 52 | 12.1 | Trips, warnings and limits..... | 165 |
| 10.5.1 | Process value | 52 | 12.2 | Trip conditions, causes and remedial action | 166 |
| 10.6 | Description of the Elnt formats | 53 | 12.2.1 | Technically qualified personnel..... | 166 |
| 11. | Functional Description..... | 55 | 12.2.2 | Opening the AC drive | 166 |
| 11.1 | Preferred View [100]..... | 55 | 12.2.3 | Precautions to take with a connected motor | 166 |
| 11.1.1 | 1st Line [110]..... | 55 | 12.2.4 | Autoreset Trip | 166 |
| 11.1.2 | 2nd Line [120] | 56 | 12.3 | Maintenance | 170 |
| 11.2 | Main Setup [200]..... | 56 | 13. | Options..... | 171 |
| 11.2.1 | Operation [210]..... | 56 | 13.1 | Options for the control panel..... | 171 |
| 11.2.2 | Remote Signal Level/Edge [21A]..... | 60 | 13.2 | Handheld Control Panel 2.0 | 171 |
| 11.2.3 | Mains supply voltage [21B]..... | 61 | 13.3 | EmoSoftCom..... | 171 |
| 11.2.4 | Motor Data [220] | 61 | 13.4 | Brake chopper | 172 |
| 11.2.5 | Motor Protection [230] | 65 | 13.5 | I/O Board | 173 |
| 11.2.6 | Parameter Set Handling [240]..... | 68 | 13.6 | Encoder..... | 173 |
| 11.2.7 | Trip Autoreset/Trip Conditions [250]..... | 71 | 13.7 | PTC/PT100 | 173 |
| 11.2.8 | Serial Communication [260] | 78 | 13.8 | Crane option board | 173 |
| 11.3 | Process and Application Parameters [300] | 81 | 13.9 | Serial communication and fieldbus | 174 |
| 11.3.1 | Set/View Reference Value [310] | 81 | 13.10 | Standby supply board option..... | 174 |
| 11.3.2 | Process Settings [320] | 82 | 13.11 | Safe Stop option..... | 175 |
| 11.3.3 | Start/Stop settings [330] | 86 | 13.12 | Output chokes | 177 |
| 11.3.4 | Mechanical brake control..... | 90 | 13.13 | Liquid cooling | 177 |
| 11.3.5 | Speed [340]..... | 93 | 14. | Technical Data | 179 |
| 11.3.6 | Torques [350]..... | 96 | 14.1 | Electrical specifications related to model | 179 |
| 11.3.7 | Preset References [360] | 98 | 14.2 | General electrical specifications..... | 183 |
| 11.3.8 | PI Speed Control [370] | 99 | 14.3 | Operation at higher temperatures | 184 |
| 11.3.9 | PID Process Control [380] | 100 | 14.4 | Dimensions and Weights..... | 185 |
| 11.3.10 | Pump/Fan Control [390] | 104 | 14.5 | Environmental conditions..... | 186 |
| 11.3.11 | Crane Option [3A0] | 110 | 14.6 | Fuses, cable cross-sections and glands..... | 187 |
| 11.4 | Load Monitor and Process Protection [400]..... | 113 | 14.6.1 | According IEC ratings..... | 187 |
| 11.4.1 | Load Monitor [410]..... | 113 | 14.6.2 | Fuses and cable dimensions according to NEMA ratings..... | 189 |
| 11.4.2 | Process Protection [420]..... | 118 | 14.7 | Control signals..... | 192 |
| 11.5 | I/Os and Virtual Connections [500]..... | 119 | 15. | Menu List | 193 |
| 11.5.1 | Analogue Inputs [510] | 119 | Index | 201 | |
| 11.5.2 | Digital Inputs [520] | 126 | | | |
| 11.5.3 | Analogue Outputs [530] | 128 | | | |
| 11.5.4 | Digital Outputs [540] | 132 | | | |
| 11.5.5 | Relays [550] | 134 | | | |
| 11.5.6 | Virtual Connections [560]..... | 135 | | | |
| 11.6 | Logical Functions and Timers [600] | 136 | | | |
| 11.6.1 | Comparators [610] | 136 | | | |
| 11.6.2 | Logic Output Y [620]..... | 147 | | | |
| 11.6.3 | Logic Output Z [630]..... | 149 | | | |
| 11.6.4 | Timer1 [640] | 150 | | | |
| 11.6.5 | Timer2 [650] | 152 | | | |
| 11.7 | View Operation/Status [700] | 153 | | | |
| 11.7.1 | Operation [710]..... | 153 | | | |
| 11.7.2 | Status [720] | 156 | | | |
| 11.7.3 | Stored values [730] | 159 | | | |

1. Introduction

The AC drive V33 is intended for controlling the speed and torque of standard three phase asynchronous electrical motors. The AC drive (Frequency converter) is equipped with direct torque control which uses built-in digital signal processor - DSP, giving the AC drive the capability of high dynamic performance even at very low speeds without using feedback signals from the motor. Therefore the inverter is designed for use in high dynamic applications where low speed high torque and high-speed accuracy are demanded. In "simpler" application such as fans or pumps, the V33 direct torque control offers other great advantages such as insensitivity to mains disturbances or load shocks.

NOTE: Read this instruction manual carefully before starting installation, connection or working with the AC drive.

Users

This instruction manual is intended for:

- installation engineers
- maintenance engineers
- operators
- service engineers

Motors

The AC drive is suitable for use with standard 3-phase asynchronous motors. Under certain conditions it is possible to use other types of motors. Contact your supplier for details.

1.1 Delivery and unpacking

Check for any visible signs of damage. Inform your supplier immediately of any damage found. Do not install the AC drive if damage is found.

The AC drives are delivered with a template for positioning the fixing holes on a flat surface. Check that all items are present and that the type number is correct.

1.2 Using of the instruction manual

Within this instruction manual the abbreviation "AC drive" is used to indicate the complete variable speed drive as a single unit.

Check that the software version number on the first page of this manual matches the software version in the AC drive. See chapter 11.9 page 166

With help of the index and the table of contents it is easy to track individual functions and to find out how to use and set them.

The Quick Setup Card can be put in a cabinet door, so that it is always easy to access in case of an emergency.

1.3 Type code number

Fig. 1 gives an example of the type code numbering used on all AC drives. With this code number the exact type of the drive can be determined. This identification will be required for type specific information when mounting and installing. The code number is located on the product label, on the front of the unit.

| | | | | | | | | | | | | | | | | | |
|--|---|---|---|---|---|---|---|---|----|----|----|----|----|----|----|----|----|
| JNVX48-0175-0054 C E - - - A - N N N N A N - | | | | | | | | | | | | | | | | | |
| Position number: | | | | | | | | | | | | | | | | | |
| 1 | 2 | 3 | 4 | 5 | 6 | 7 | 8 | 9 | 10 | 11 | 12 | 13 | 14 | 15 | 16 | 17 | 18 |

Fig. 1 Type code number

| Position for 0003-0074 | Position for 0090-1500 | Configuration | |
|------------------------|------------------------|--|--|
| 1 | 1 | AC drive type | F33 V33 |
| 2 | 2 | Supply voltage | 48=400 V mains 52=525 V mains 69=690 V mains |
| 3 | 3 | Rated current (A) continuous | -003=2.5 A - -1K5=1500 A |
| 4 | 4 | Protection class | 20=IP20 54=IP54 |
| 5 | 5 | Control panel | --Blank panel C=Standard panel |
| 6 | 6 | EMC option | E=Standard EMC (Category C3) F=Extended EMC (Category C2) I=IT-Net |
| 7 | 7 | Brake chopper option | --No chopper B=Chopper built in D=DC+/- interface |
| 8 | 8 | Stand-by power supply option | --No SBS S=SBS included |
| - | 9 | Safe stop option (Only valid for 090-1500) | --No safe stop T=Safe stop incl. |
| 9 | 10 | Brand label | |

| Position for 0003-0074 | Position for 0090-1500 | Configuration | |
|------------------------|------------------------|---|--|
| 10 | - | Painted AC drive (Only valid for 003-074) | A=Standard paint B=White paint RAL9010 |
| 11 | 11 | Coated boards, option | - =Standard boards V=Coated boards |
| 12 | 12 | Option position 1 | N=No option C=Crane I/O E=Encoder P=PTC/PT100 I=Extended I/O S=Safe Stop (only 003-074) |
| 13 | 13 | Option position 2 | |
| 14 | 14 | Option position 3 | |
| 15 | 15 | Option position, communication | N=No option D=DeviceNet P=Profibus S=RS232/485 M=Modbus/TCP |
| 16 | 16 | Software type | A=Standard |
| 17 | - | Motor PTC. (Only valid for 003-074) | N=No option P=PTC |
| 18 | - | Gland kit. (Only valid for 003-074) | - =Glands not included G=Gland kit included |

1.4 Standards

The AC drives described in this instruction manual comply with the standards listed in Table 1. For the declarations of conformity and manufacturer's certificate, contact your supplier for more information.

1.4.1 Product standard for EMC

Product standard EN(IEC)61800-3, second edition of 2004 defines the:

First Environment (Extended EMC) as environment that includes domestic premises. It also includes establishments directly connected without intermediate transformers to a low voltage power supply network that supplies buildings used for domestic purposes.

Category C2: Power Drive System (PDS) of rated voltage <1.000 V, which is neither a plug in device nor a movable device and, when used in the first environment, is intended to be installed and commissioned only by a professional.

Second environment (Standard EMC) includes all other establishments.

Category C3: PDS of rated voltage <1.000 V, intended for use in the second environment and not intended for use in the first environment.

Category C4: PDS or rated voltage equal or above 1.000 V, or rated current equal to or above 400 A, or intended for use in complex systems in the second environment.

The AC drive complies with the product standard EN(IEC) 61800-3:2004 (Any kind of metal screened cable may be used). The standard AC drive is designed to meet the requirements according to category C3.

By using the optional "Extended EMC" filter the AC drive fulfils requirements according to category C2,



WARNING!

In a domestic environment this product may cause radio interference, in which case it may be necessary to take adequate additional measures.



WARNING!

The standard AC drive, complying with category C3, is not intended to be used on a low-voltage public network which supplies domestic premises; radio interference is expected if used in such a network. Contact your supplier if you need additional measures.

Table 1 Standards

| Market | Standard | Description |
|----------|--------------------------|---|
| European | EMC Directive | 2004/108/EEC |
| | Low Voltage Directive | 2006/95/EC |
| | WEEE Directive | 2002/96/EC |
| All | EN 60204-1 | Safety of machinery - Electrical equipment of machines Part 1: General requirements. |
| | EN(IEC)61800-3:2004 | Adjustable speed electrical power drive systems Part 3: EMC requirements and specific test methods. EMC Directive: Declaration of Conformity and CE marking |
| | EN(IEC)61800-5-1 Ed. 2.0 | Adjustable speed electrical power drive systems Part 5-1. Safety requirements - Electrical, thermal and energy. Low Voltage Directive: Declaration of Conformity and CE marking |
| | IEC 60721-3-3 | Classification of environmental conditions. Air quality chemical vapours, unit in operation. Chemical gases 3C2, Solid particles 3S2. Optional with coated boards Unit in operation. Chemical gases Class 3C3, Solid particles 3S2. |
| | UL508C | UL Safety standard for Power Conversion Equipment |
| USA | ≥90 A only UL 840 | UL Safety standard for Power Conversion Equipment power conversion equipment. Insulation coordination including clearances and creepage distances for electrical equipment. |
| Russian | GOST R | For all sizes |

1.5 Dismantling and scrapping

The enclosures of the drives are made from recyclable material as aluminium, iron and plastic. Each drive contains a number of components demanding special treatment, for example electrolytic capacitors. The circuit boards contain small amounts of tin and lead. Any local or national regulations in force for the disposal and recycling of these materials must be complied with.

1.5.1 Disposal of old electrical and electronic equipment

This information is applicable in the European Union and other European countries with separate collection systems.

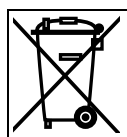

This symbol on the product or on its packaging indicates that this product shall be taken to the applicable collection point for the recycling of electrical and electronic equipment. By ensuring this product is disposed of correctly, you will help prevent potentially negative consequences for the environment and human health, which could otherwise be caused by inappropriate waste handling of this product. The recycling of materials will help to conserve natural resources. For more detailed information about recycling this product, please contact the local distributor of the product.

1.6 Glossary

1.6.1 Abbreviations and symbols

In this manual the following abbreviations are used:

Table 2 Abbreviations

| Abbreviation/ symbol | Description |
|---|--|
| DSP | Digital signals processor |
| AC drive | Frequency converter |
| PEBB | Power Electronic Building Block |
| IGBT | Insulated Gate Bipolar Transistor |
| CP | Control panel, the programming and presentation unit on the AC drive |
| EInt | Communication format |
| UInt | Communication format (Unsigned integer) |
| Int | Communication format (Integer) |
| Long | Communication format |
|  | The function cannot be changed in run mode |

1.6.2 Definitions

In this manual the following definitions for current, torque and frequency are used:

Table 3 Definitions

| Name | Description | Quantity |
|------------|------------------------------------|-----------|
| I_{IN} | Nominal input current of AC drive | A_{RMS} |
| I_{NOM} | Nominal output current of AC drive | A_{RMS} |
| I_{MOT} | Nominal motor current | A_{RMS} |
| P_{NOM} | Nominal power of AC drive | kW |
| P_{MOT} | Motor power | kW |
| T_{NOM} | Nominal torque of motor | Nm |
| T_{MOT} | Motor torque | Nm |
| f_{OUT} | Output frequency of AC drive | Hz |
| f_{MOT} | Nominal frequency of motor | Hz |
| n_{MOT} | Nominal speed of motor | rpm |
| I_{CL} | Maximum output current | A_{RMS} |
| Speed | Actual motor speed | rpm |
| Torque | Actual motor torque | Nm |
| Sync speed | Synchronous speed of the motor | rpm |

2. Mounting

This chapter describes how to mount the AC drive.

Before mounting it is recommended that the installation is planned out first.

- Be sure that the AC drive suits the mounting location.
- The mounting site must support the weight of the AC drive.
- Will the AC drive continuously withstand vibrations and/or shocks?
- Consider using a vibration damper.
- Check ambient conditions, ratings, required cooling air flow, compatibility of the motor, etc.
- Know how the AC drive will be lifted and transported.

2.1 Lifting instructions

Note: To prevent personal risks and any damage to the unit during lifting, it is advised that the lifting methods described below are used.

Recommended for AC drive models
-0090 to -0250

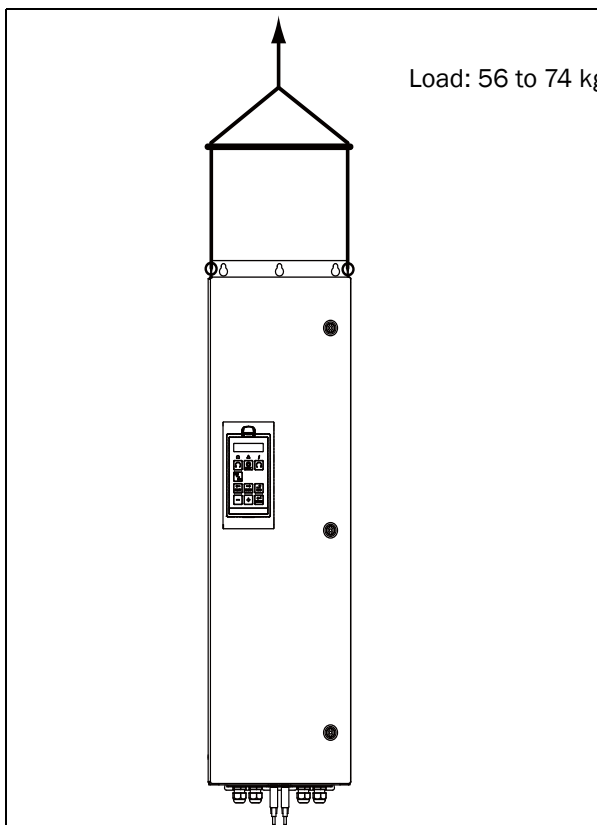

Fig. 2 Lifting AC drive model -0090 to -0250

Recommended for AC drive models
-0300 to -1500

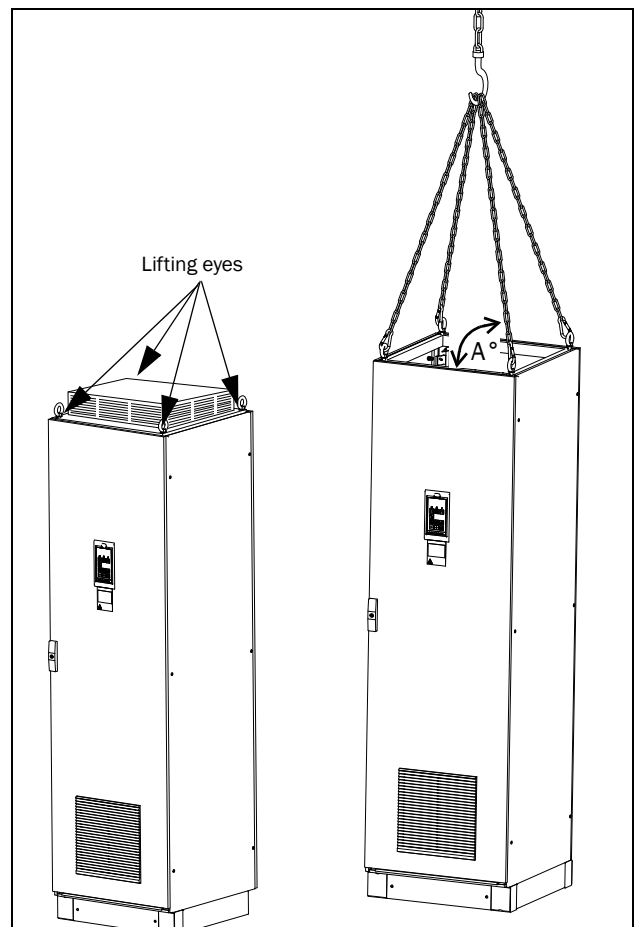

Fig. 3 Remove the roof unit and use the lifting eyes to lift single unit 600mm and 900mm.

Single cabinet drives can be lifted/transported safely using the eyebolts supplied and lifting cables/chains as in illustration Fig. 3 above.

Depending on the cable/chain angle A (in Fig. 3), following loads are permitted:

| Cable/chain angle A | Permitted load |
|---------------------|----------------|
| 45 ° | 4 800 N |
| 60 ° | 6 400 N |
| 90 ° | 13 600N |

Regarding lifting instructions for other cabinet sizes, please contact your supplier.

2.2 Stand-alone units

The AC drive must be mounted in a vertical position against a flat surface. Use the template (delivered together with the AC drive) to mark out the position of the fixing holes.

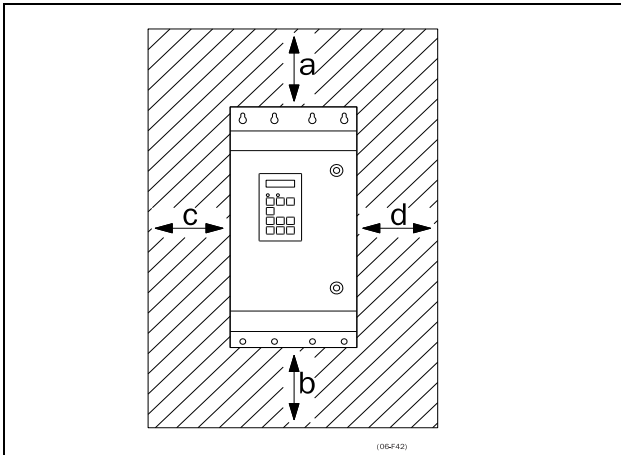

Fig. 4 AC drive mounting model 0003 to 1500

2.2.1 Cooling

Fig. 4 shows the minimum free space required around the AC drive for the models 0003 to 1500 in order to guarantee adequate cooling. Because the fans blow the air from the bottom to the top it is advisable not to position an air inlet immediately above an air outlet.

The following minimum separation between two AC drives, or a AC drive and a non-dissipating wall must be maintained. Valid if free space on opposite side.

Table 4 Mounting and cooling

| | | 0003-0018 | 0026-0074 | 0090-0250 | 0300-1500 cabinet |
|------------------------------|---|-----------|-----------|-----------|-------------------|
| V33-V33, side-by-side (mm) | a | 200 | 200 | 200 | 100 |
| | b | 200 | 200 | 200 | 0 |
| | c | 0 | 0 | 0 | 0 |
| | d | 0 | 0 | 0 | 0 |
| V33-wall, wall-one side (mm) | a | 100 | 100 | 100 | 100 |
| | b | 100 | 100 | 100 | 0 |
| | c | 0 | 0 | 0 | 0 |
| | d | 0 | 0 | 0 | 0 |

NOTE: When a 0300 to 1500 model is placed between two walls, a minimum distance at each side of 200 mm must be maintained.

2.2.2 Mounting schemes

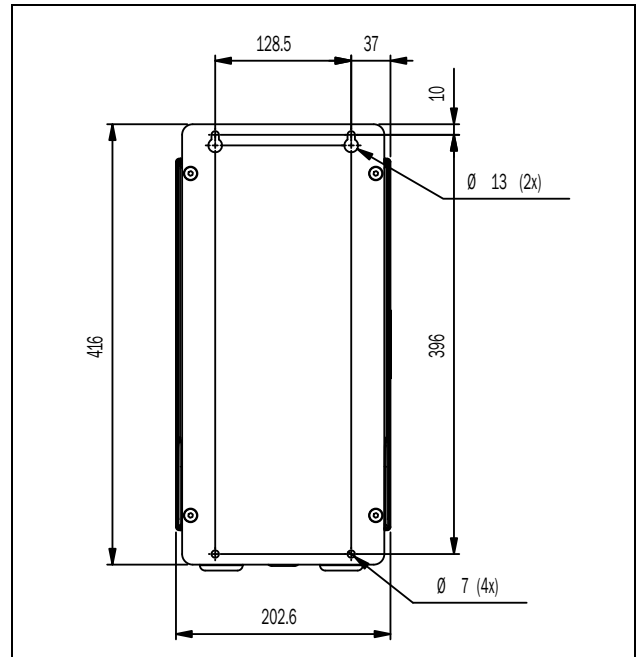

Fig. 5 JNVX48/52: Model 0003 to 0018 (B)

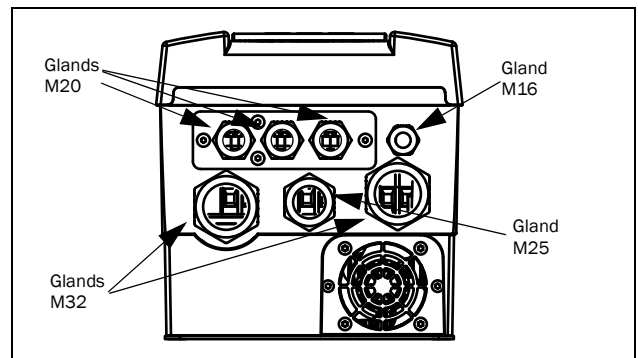

Fig. 6 Cable interface for mains, motor and communication, JNVX48/52: Model 0003 to 0018 (B)

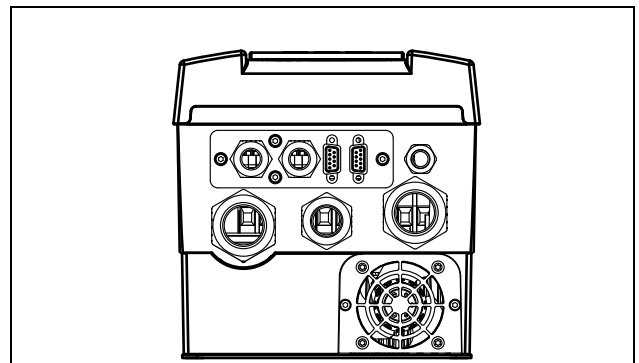

Fig. 7 JNVX48/52: Model 0003 to 0018 (B), with optional gland plate



Fig. 8 JNVX48/52: Model 0026 to 0046 (C)

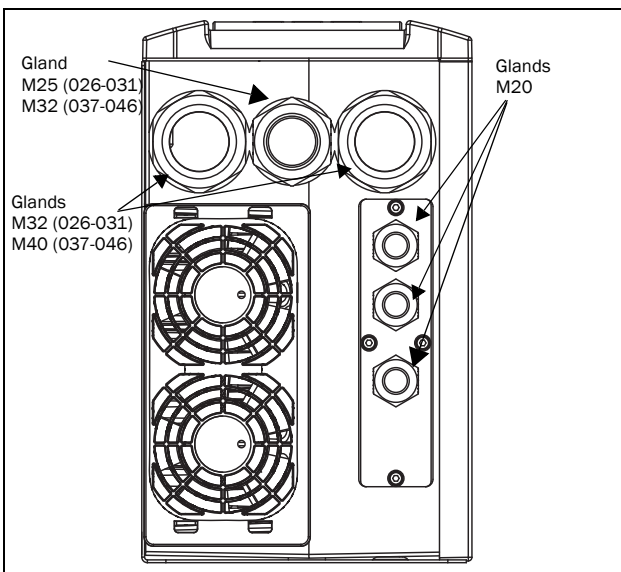

Fig. 9 Cable interface for mains, motor and communication, JNVX48/52: Model 0026 to 0046 (C)

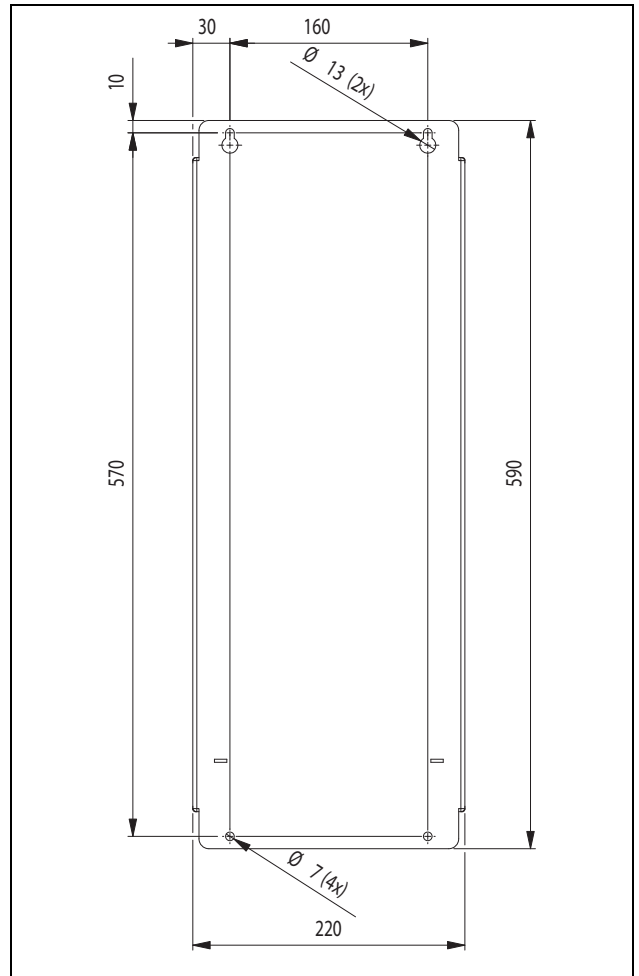

Fig. 10 JNVX48/52: Model 0061 to 0074 (D)

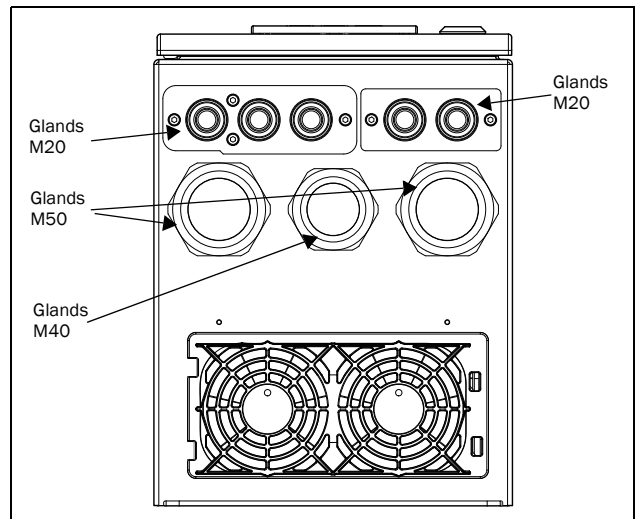

Fig. 11 Cable interface for mains, motor and communication, JNVX48/52: Model 0061 to 0074 (D).

NOTE: Glands for size B, C and D are available as option kit.

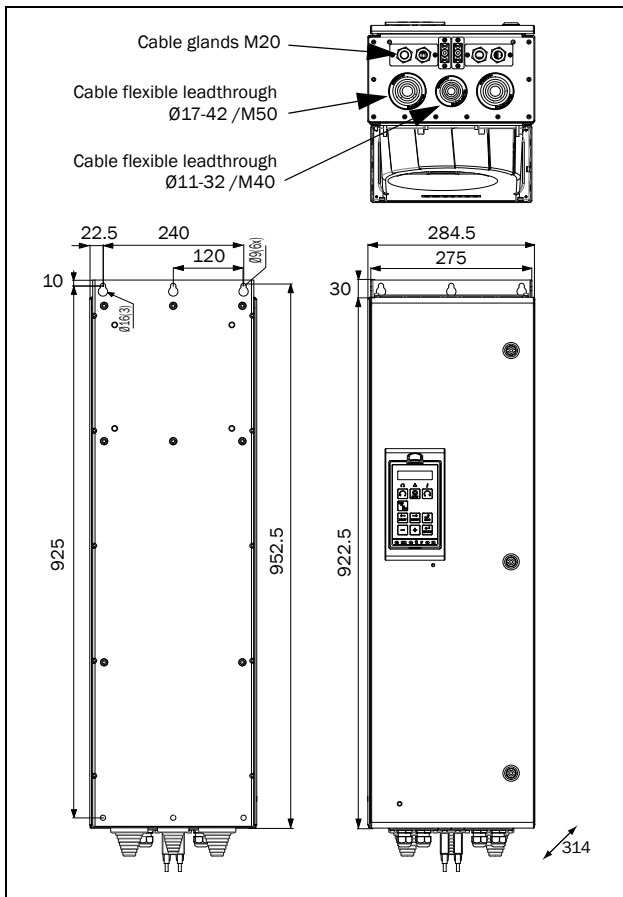

Fig. 12 JNVX48: Model 0090 to 0175 (E) including cable interface for mains, motor and communication

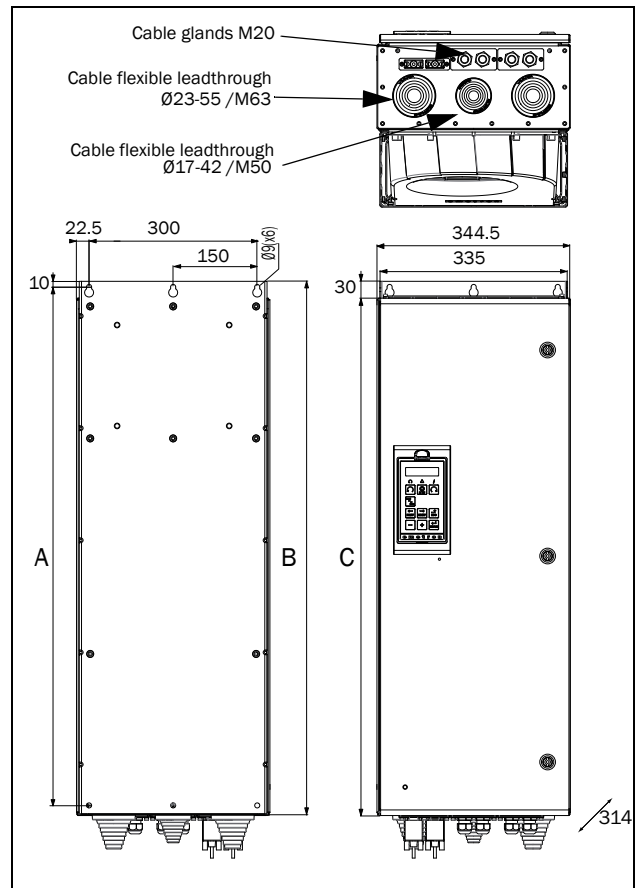

Fig. 13 JNVX48: Model 0210 to 0250 (F)
JNVX69: Model 0090 to 0175 (F69) including cable interface for mains, motor and communication

| Frame | JNVX model | Dimension in mm | | |
|-------|-------------|-----------------|------|------|
| | | A | B | C |
| F | 0210 - 0250 | 925 | 950 | 920 |
| F69 | 0090 - 0175 | 1065 | 1090 | 1060 |

2.3 Cabinet mounting

2.3.1 Cooling

If the variable speed drive is installed in a cabinet, the rate of airflow supplied by the cooling fans must be taken into consideration.

Table 5 Flow rates cooling fans

| Frame | JNVX Model | Flow rate [m ³ /hour] |
|-------|-------------|----------------------------------|
| B | 0003 - 0018 | 75 |
| C | 0026 - 0031 | 120 |
| C | 0037 - 0046 | 170 |
| D | 0061 - 0074 | 170 |
| E | 0090 - 0175 | 510 |
| F | 0210 - 0250 | 800 |
| F69 | 0090 - 0175 | |
| G | 0300 - 0375 | 1020 |
| H | 0430 - 0500 | 1600 |
| H69 | 0210 - 0375 | |
| I | 0600 - 0750 | 2400 |
| I69 | 0430 - 0500 | |
| J | 0860 - 1000 | 3200 |
| J69 | 0600 - 0650 | |
| K | 1200 - 1500 | 4800 |
| K69 | 0750 - 1000 | |

NOTE: For the models 0860 to 1500 the mentioned amount of air flow should be divided equally over the two cabinets.

2.3.2 Recommended free space in front of cabinet

All cabinet mounted AC drives are designed in modules, so called PEBBs. These PEBBs can be folded out to be replaced. To be able to remove a PEBB in the future, we recommend 1.30 meter free space in front of the cabinet, see Fig. 14.

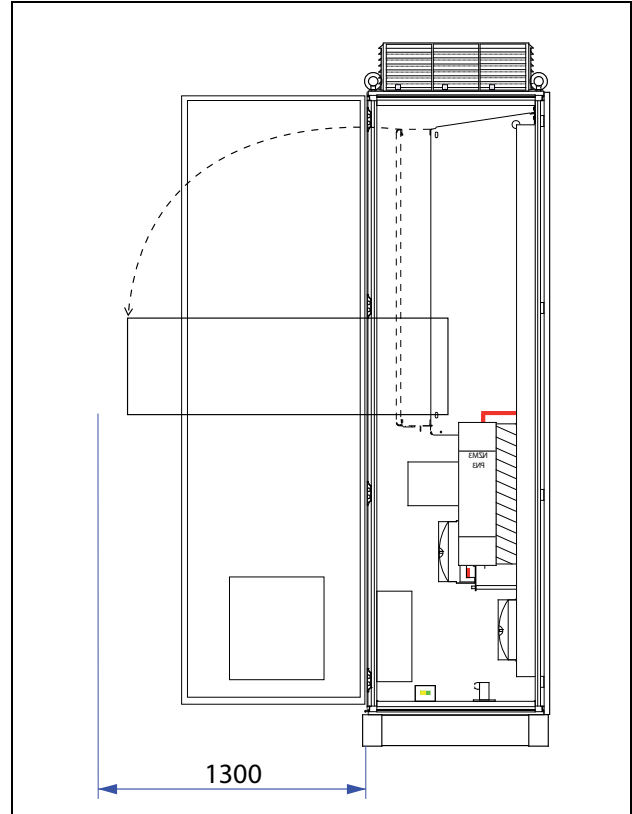

Fig. 14 Recommended free space in front of the cabinet mounted AC drive

2.3.3 Mounting schemes

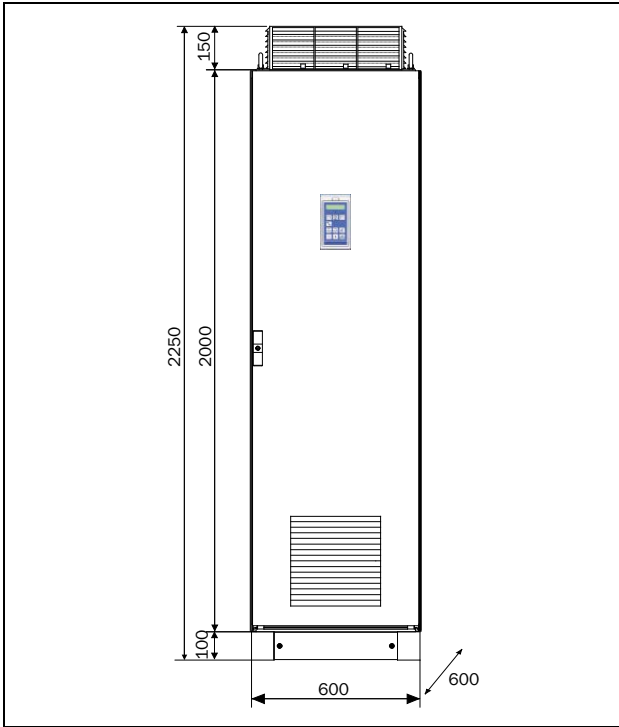

Fig. 15 JNVX48: Model 0300 to 0500 (G and H)
JNVX69: Model 0210 to 0375 (H69)

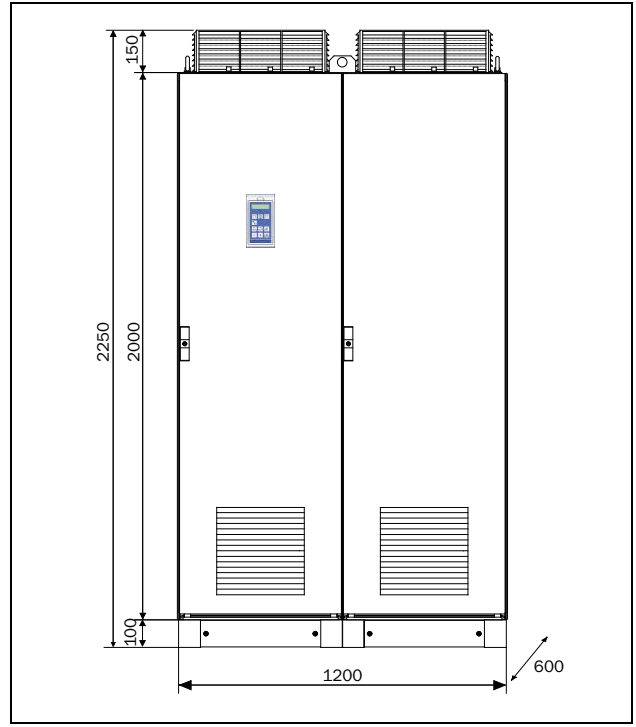

Fig. 17 JNVX48: Model 0860 to 1000 (J)
JNVX69: Model 0600 to 0650 (J69)

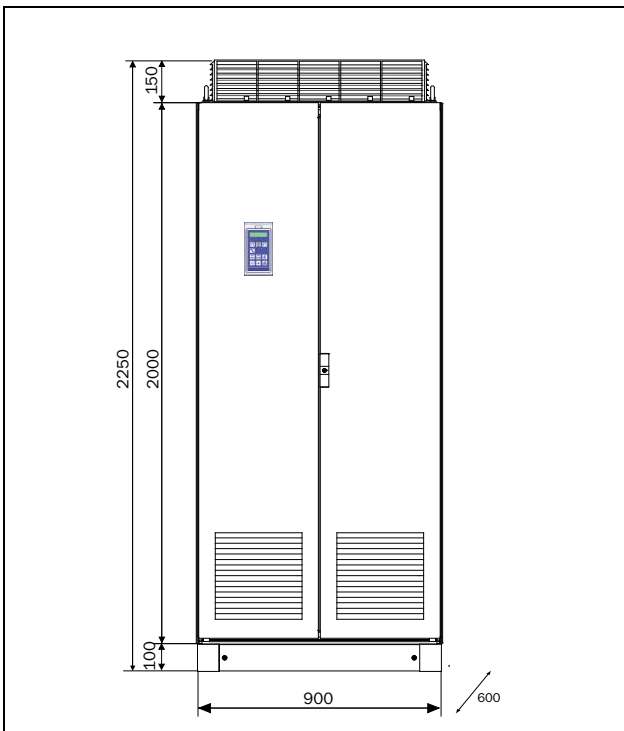

Fig. 16 JNVX48: Model 0600 to 0750 (I)
JNVX69: Model 0430 to 0500 (I69)

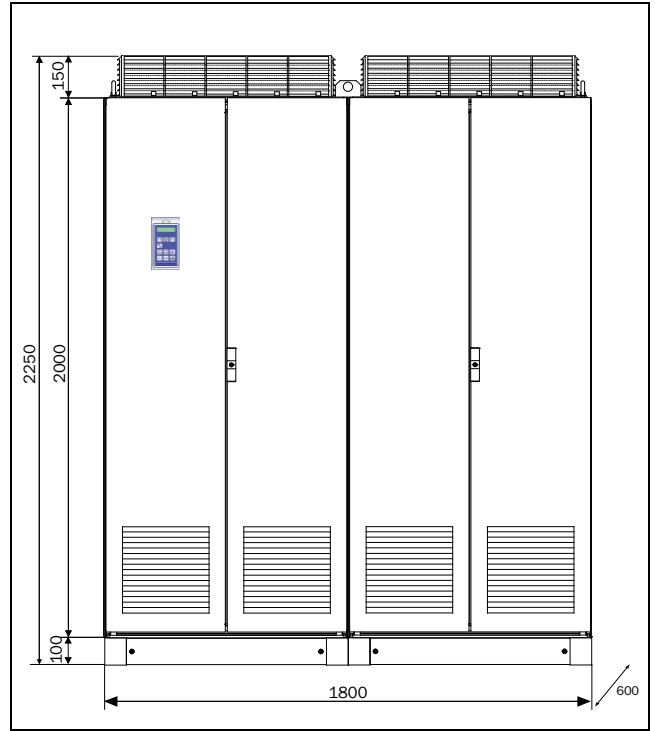

Fig. 18 JNVX48: Model 1200 to 1500 (K)
JNVX69: Model 0750 to 1000 (K69)

3. Installation

The description of installation in this chapter complies with the EMC standards and the Machine Directive.

Select cable type and screening according to the EMC requirements valid for the environment where the AC drive is installed.

3.1 Before installation

Read the following checklist and prepare for your application before installation.

- Local or remote control.
- Long motor cables (>100m), refer to section Long motor cables page 18.
- Motors in parallel, refer to menu [213] page 65.
- Functions used.
- Suitable AC drive size in proportion to the motor/application.

If the AC drive is temporarily stored before being connected, please check the technical data for environmental conditions. If the AC drive is moved from a cold storage room to the room where it is to be installed, condensation can form on it. Allow the AC drive to become fully acclimatised and wait until any visible condensation has evaporated before connecting the mains voltage.

3.2 Cable connections for model 0003 to 0074

3.2.1 Mains cables

Dimension the mains and motor cables according to local regulations. The cable must be able to carry the AC drive load current.

Recommendations for selecting mains cables

- To fulfil EMC purposes it is not necessary to use screened mains cables.
- Use heat-resistant cables, +60°C or higher.
- Dimension the cables and fuses in accordance with local regulations and the nominal current of the motor. See table 49, page 191.
- The litz ground connection see fig. 23, is only necessary if the mounting plate is painted. All the AC drives have an unpainted back side and are therefore suitable for mounting on an unpainted mounting plate.

Connect the mains cables according to fig. 19 or 20. The AC drive has as standard a built-in RFI mains filter that complies with category C3 which suits the Second Environment standard.

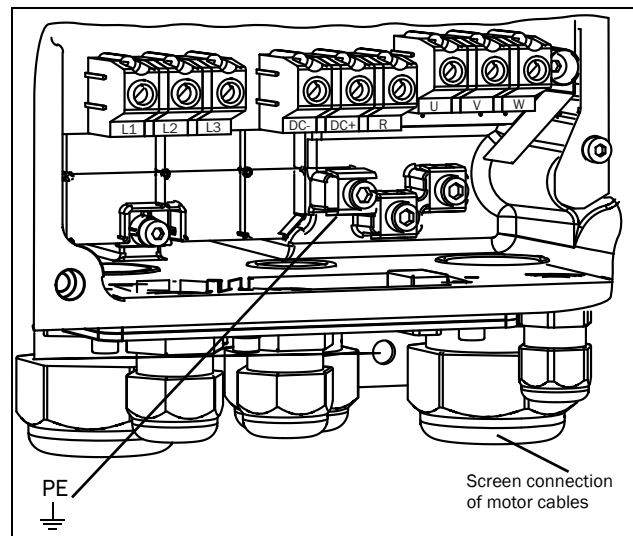

Fig. 19 Mains and motor connections, model 0003-0018

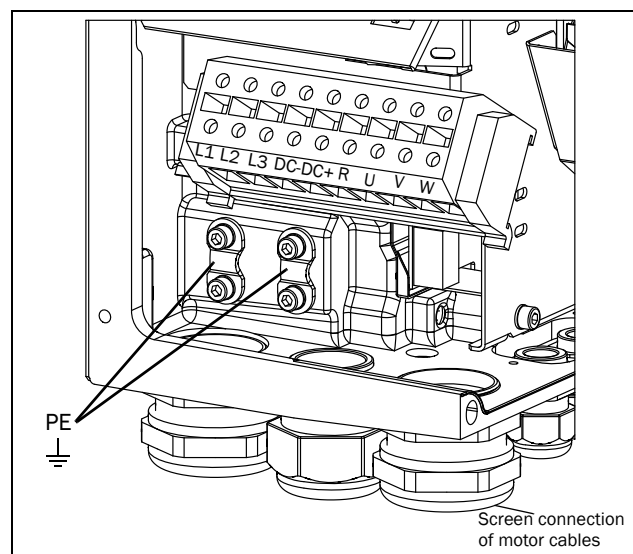

Fig. 20 Mains and motor connections, 0026-0046

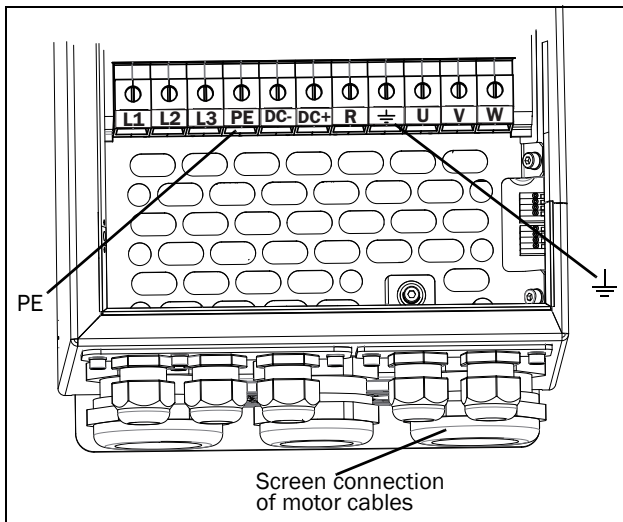

Fig. 21 Mains and motor connection, model 0061 - 0074

Table 6 Mains and motor connections

| | |
|------------------|---|
| L1, L2, L3 PE | Mains supply, 3-phase Safety earth (protected earth) |
| U, V, W | Motor earth Motor output, 3-phase |
| DC-, DC+, R | Brake resistor, DC-link connections (optional) |

NOTE: The Brake and DC-link Terminals are only fitted if the DC+/DC- option or Brake Chopper Option is built-in.



WARNING!
The Brake Resistor must be connected between terminals DC+ and R.



WARNING!
In order to work safely, the mains earth must be connected to PE and the motor earth to .

3.2.2 Motor cables

To comply with the EMC emission standards the AC drive is provided with a RFI mains filter. The motor cables must also be screened and connected on both sides. In this way a so-called "Faraday cage" is created around the AC drive, motor cables and motor. The RFI currents are now fed back to their source (the IGBTs) so the system stays within the emission levels.

Recommendations for selecting motor cables

- Use screened cables according to specification in table 7. Use symmetrical shielded cable; three phase conductors and a concentric or otherwise symmetrically constructed PE conductor, and a shield.
- When the conductivity of the cable PE conductor is <50% of the conductivity of the phase conductor, a separate PE conductor is required.
- Use heat-resistant cables, +60 °C or higher.
- Dimension the cables and fuses in accordance with the nominal output current of the motor. See table 49, page 191.
- Keep the motor cable between AC drive and motor as short as possible.
- The screening must be connected with a large contact surface of preferable 360° and always at both ends, to the motor housing and the AC drive housing. When painted mounting plates are used, do not be afraid to scrape away the paint to obtain as large contact surface as possible at all mounting points for items such as saddles and the bare cable screening. Relying just on the connection made by the screw thread is not sufficient.

NOTE: It is important that the motor housing has the same earth potential as the other parts of the machine.

- The litz ground connection, see fig. 23, is only necessary if the mounting plate is painted. All the AC drives have an unpainted back side and are therefore suitable for mounting on an unpainted mounting plate.

Connect the motor cables according to U - U, V - V and W - W, see Fig. 19, Fig. 20 and Fig. 21 .

NOTE: The terminals DC-, DC+ and R are options.

Switches between the motor and the AC drive

If the motor cables are to be interrupted by maintenance switches, output coils, etc., it is necessary that the screening is continued by using metal housing, metal mounting plates, etc. as shown in the Fig. 23.

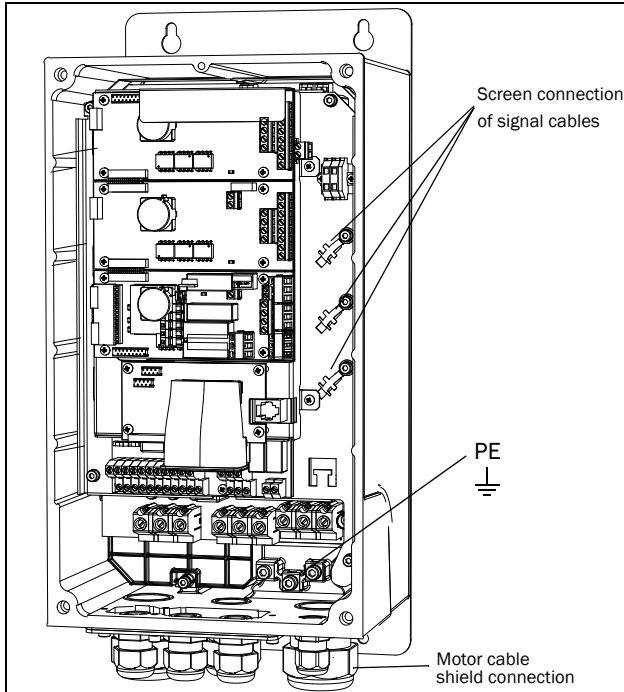

Fig. 22 Screen connection of cables.

Pay special attention to the following points:

- If paint must be removed, steps must be taken to prevent subsequent corrosion. Repaint after making connections!
- The fastening of the whole AC drive housing must be electrically connected with the mounting plate over an area which is as large as possible. For this purpose the removal of paint is necessary. An alternative method is to connect the AC drive housing to the mounting plate with as short a length of litz wire as possible.
- Try to avoid interruptions in the screening wherever possible.
- If the AC drive is mounted in a standard cabinet, the internal wiring must comply with the EMC standard. Fig. 23 shows an example of a AC drive built into a cabinet.

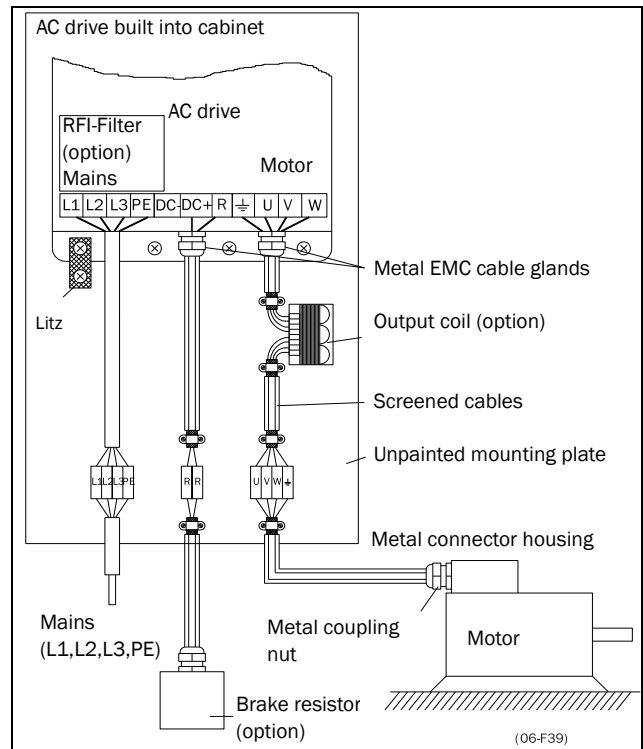

Fig. 23 AC drive in a cabinet on a mounting plate

Fig. 24 shows an example when there is no metal mounting plate used (e.g. if IP54 AC drives are used). It is important to keep the “circuit” closed, by using metal housing and cable glands.

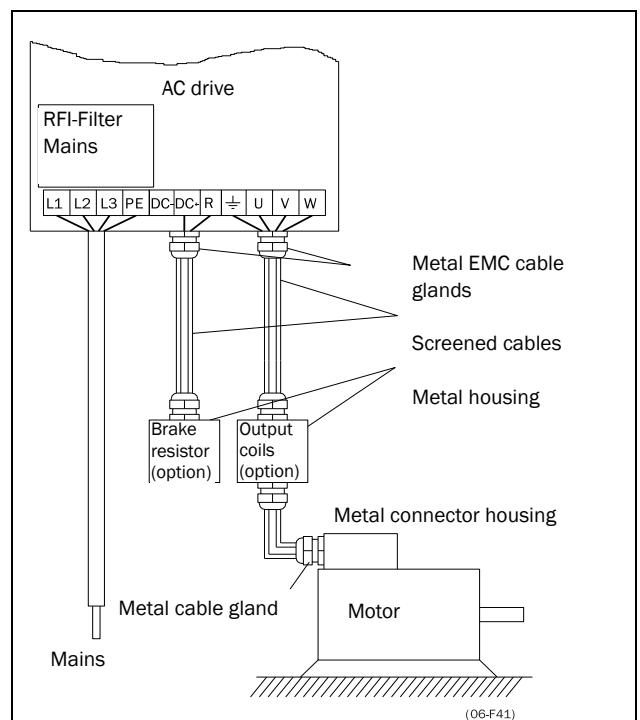

Fig. 24 AC drive as stand alone

Connect motor cables

1. Remove the cable interface plate from the AC drive housing.
2. Put the cables through the glands.
3. Strip the cable according to Table 8.
4. Connect the stripped cables to the respective motor terminal.
5. Put the cable interface plate in place and secure with the fixing screws.
6. Tighten the EMC gland with good electrical contact to the motor and brake chopper cable screens.

Placing of motor cables

Keep the motor cables as far away from other cables as possible, especially from control signals. The minimum distance between motor cables and control cables is 300 mm.

Avoid placing the motor cables in parallel with other cables.

The power cables should cross other cables at an angle of 90°.

Long motor cables

If the connection to the motor is longer than 100 m (40 m for models 0003-0018), it is possible that capacitive current peaks will cause tripping at overcurrent. Using output coils can prevent this. Contact the supplier for appropriate coils.

Switching in motor cables

Switching in the motor connections is not advisable. In the event that it cannot be avoided (e.g. emergency or maintenance switches) only switch if the current is zero. If this is not done, the AC drive can trip as a result of current peaks.

3.3 Connection of motor and mains cables for model 0090 and up

AC drive JNVX48-0090 and up, JNVX69-0090 and up

To simplify the connection of thick motor and mains cables to the AC drive, the cable interface plate can be removed.

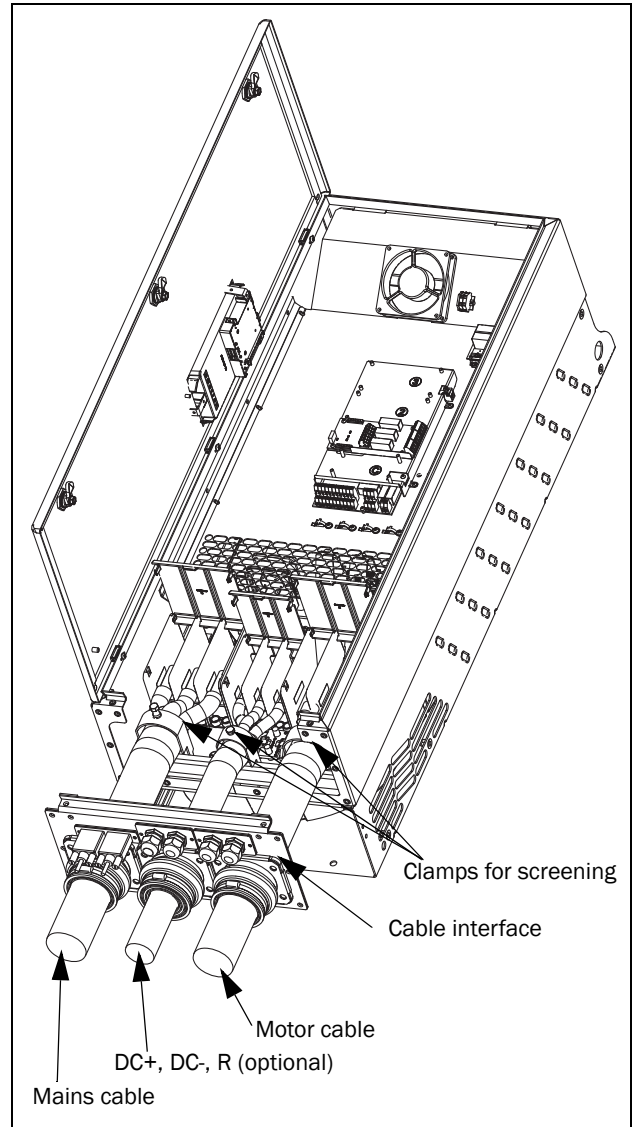

Fig. 25 Connecting motor and mains cables

1. Remove the cable interface plate from the AC drive housing.
2. Put the cables through the glands.
3. Strip the cable according to Table 8.
4. Connect the stripped cables to the respective mains/motor terminal.
5. Fix the clamps on appropriate place and tighten the cable in the clamp with good electrical contact to the cable screen.
6. Put the cable interface plate in place and secure with the fixing screws.

AC drive model 0048-0300 & 0069-0210 and up

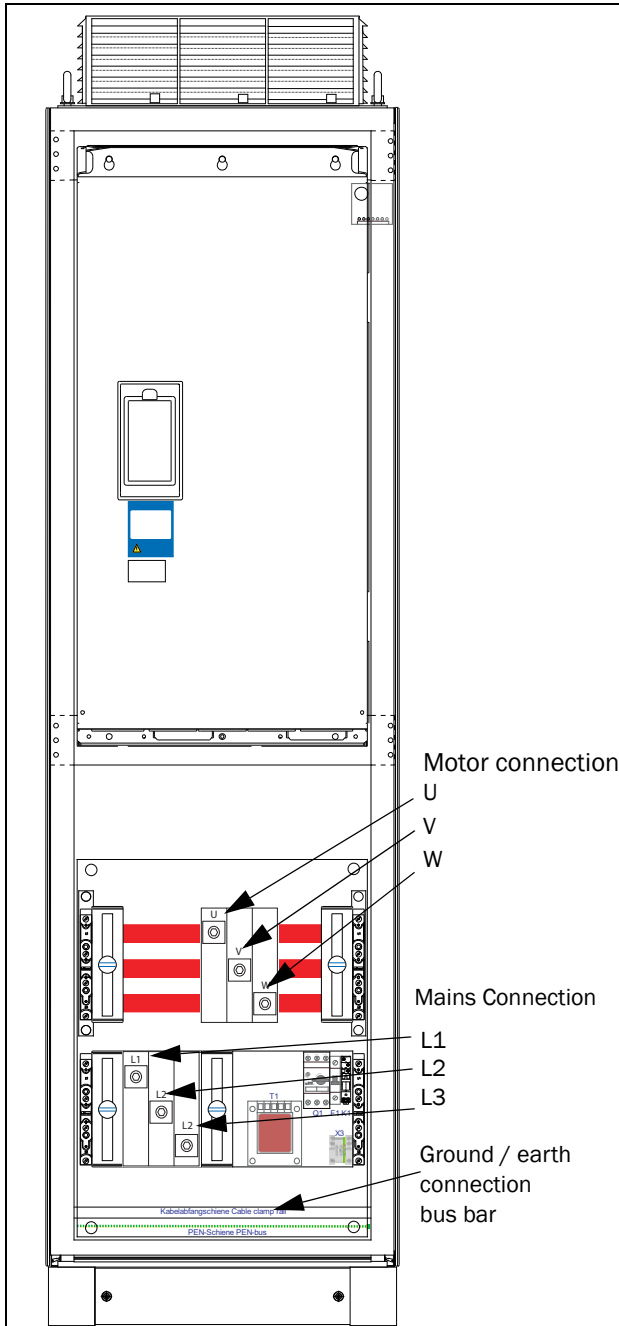

Fig. 26 Connect motor cables and mains cables to the terminals and earth/ground to the bus bar.

AC drive models 48-0300 & 0069-0210 and up are supplied with power clamps for mains and motors, for connection of PE and earth there is a bus bar.

For all type of wires to be connected the stripping length should be 32 mm.

3.3.1 Connection of mains and motor cables on IP20 modules

The IP 20 modules are delivered complete with factory mounted cables for mains and motor. The length of the cables are app. 1100 mm. The cables are marked L1, L2, L3 for mains connection and U, V, W for motor connection.

For detailed information about use of the IP20 modules, please contact your supplier.

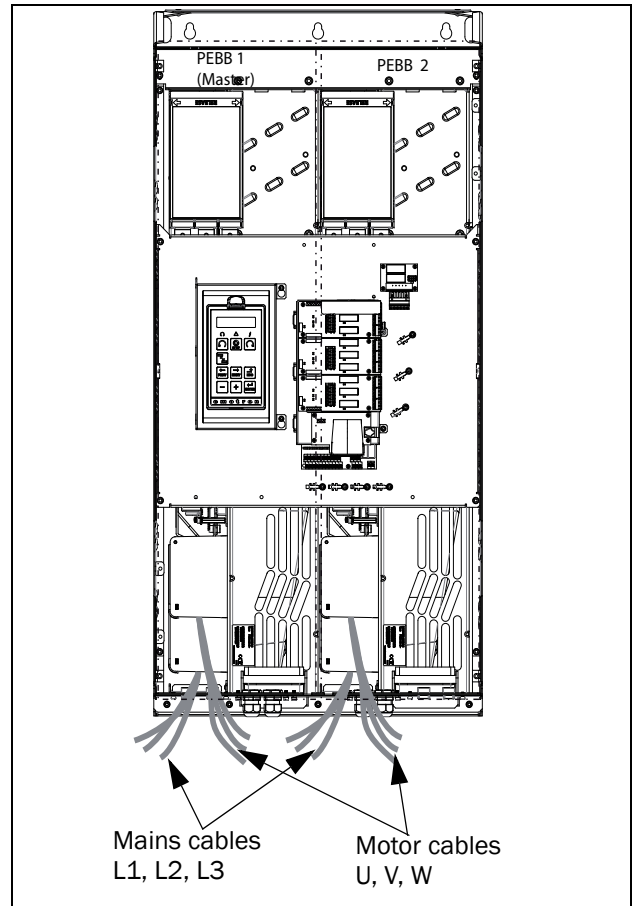

Fig. 27 IP20 module size G, with qty 2 x 3 mains cables and qty 2 x 3 motor cables.

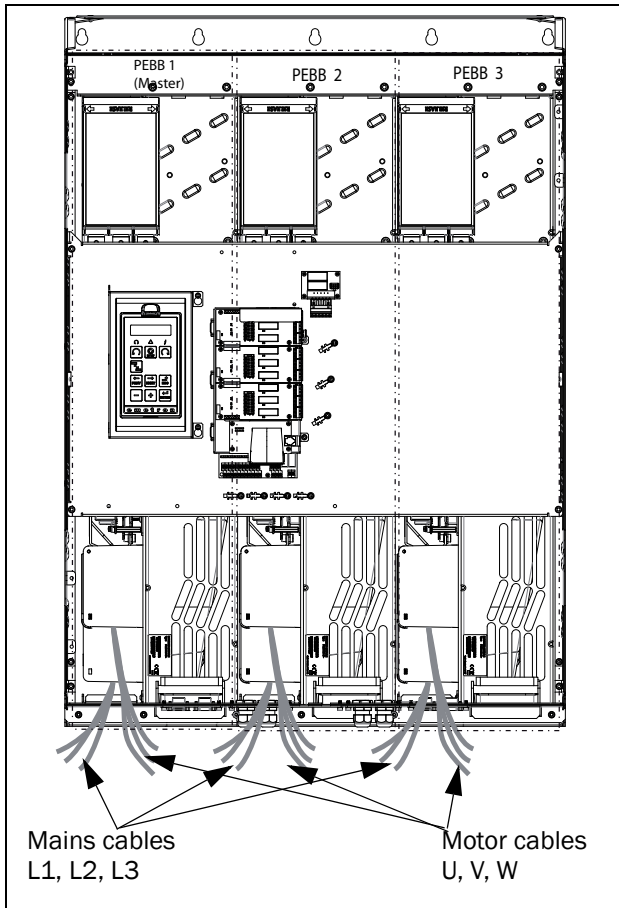

Fig. 28 IP20 module size H/H69 with qty 3 x 3 Mains cables and qty 3 x 3 motor cables.

3.4 Cable specifications

Table 7 Cable specifications

| Cable | Cable specification |
|---------|---|
| Mains | Power cable suitable for fixed installation for the voltage used. |
| Motor | Symmetrical three conductor cable with concentric protection (PE) wire or a four conductor cable with compact low-impedance concentric shield for the voltage used. |
| Control | Control cable with low-impedance shield, screened. |

3.5 Stripping lengths

Fig. 29 indicates the recommended stripping lengths for motor and mains cables.

Table 8 Stripping lengths for mains and motor cables

| Model | Mains cable | | Motor cable | | |
|--------------------------------------|-------------|--------|-------------|--------|--------|
| | a (mm) | b (mm) | a (mm) | b (mm) | c (mm) |
| 0003-0018 | 90 | 10 | 90 | 10 | 20 |
| 0026-0046 | 150 | 14 | 150 | 14 | 20 |
| 0061-0074 | 110 | 17 | 110 | 17 | 34 |
| 0090-0175 | 160 | 16 | 160 | 16 | 41 |
| JNVX48-0210-0250 JNVX69-0090-0175 | 170 | 24 | 170 | 24 | 46 |

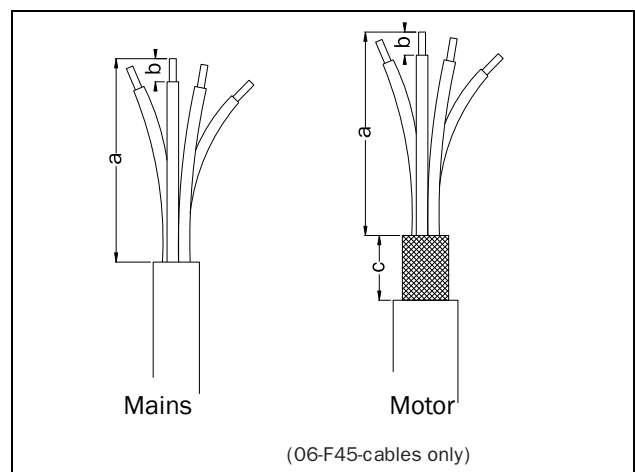

Fig. 29 Stripping lengths for cables

3.5.1 Dimension of cables and fuses

Please refer to the chapter Technical data, section 14.7, page 191.

3.5.2 Tightening torque for mains and motor cables

Table 9 Model JNVX48/52 0003 to 0046

| | Brake chopper | Mains/motor |
|-----------------------|---------------|-------------|
| Tightening torque, Nm | 1.2-1.4 | 1.2-1.4 |

Table 10 Model JNVX48/52 0061 to 0074

| | All cables 60 A | All cables 73 A |
|-----------------------|-----------------|-----------------|
| Tightening torque, Nm | 2.8 | 5.0 |

Table 11 Model JNVX48 0090 to 0109

| | Brake chopper | Mains/motor |
|---------------------------------|---------------|-------------|
| Block, mm ² | 95 | 95 |
| Cable diameter, mm ² | 16-95 | 16-95 |
| Tightening torque, Nm | 14 | 14 |

Table 12 Model JNVX48 0146 to 0175

| | Brake chopper | Mains/motor | |
|---------------------------------|---------------|-------------|---------|
| Block, mm ² | 95 | 150 | |
| Cable diameter, mm ² | 16-95 | 35-95 | 120-150 |
| Tightening torque, Nm | 14 | 14 | 24 |

Table 13 Model JNVX48 0210 to 0250 and JNVX69 0090 to 0175

| | Brake chopper | | Mains/motor | |
|---------------------------------|---------------|---------|-------------|--------|
| Block, mm ² | 150 | | 240 | |
| Cable diameter, mm ² | 35-95 | 120-150 | 35-70 | 95-240 |
| Tightening torque, Nm | 14 | 24 | 14 | 24 |

3.6 Thermal protection on the motor

Standard motors are normally fitted with an internal fan. The cooling capacity of this built-in fan is dependent on the frequency of the motor. At low frequency, the cooling capacity will be insufficient for nominal loads. Please contact the motor supplier for the cooling characteristics of the motor at lower frequency.



WARNING!

Depending on the cooling characteristics of the motor, the application, the speed and the load, it may be necessary to use forced cooling on the motor.

Motor thermistors offer better thermal protection for the motor. Depending on the type of motor thermistor fitted, the optional PTC input may be used. The motor thermistor gives a thermal protection independent of the speed of the motor, thus of the speed of the motor fan. See the functions, Motor I²t type [231] and Motor I²t current [232].

3.7 Motors in parallel

It is possible to have motors in parallel as long as the total current does not exceed the nominal value of the AC drive. The following has to be taken into account when setting the motor data:

| | |
|--------------------------------|--|
| Menu [221] Motor Voltage: | The motors in parallel must have the same motor voltage. |
| Menu [222] Motor Frequency: | The motors in parallel must have the same motor frequency. |
| Menu [223] Motor Power: | Add the motor power values for the motors in parallel. |
| Menu [224] Motor Current: | Add the current for the motors in parallel. |
| Menu [225] Motor Speed: | Set the average speed for the motors in parallel. |
| Menu [227] Motor Cos PHI: | Set the average Cos PHI value for the motors in parallel. |

NOTE: The shafts of the motors in parallel must be physically connected to obtain correct torque and speed control.

4. Control Connections

4.1 Control board

Fig. 30 shows the layout of the control board which is where the parts most important to the user are located. Although the control board is galvanically isolated from the mains, for safety reasons do not make changes while the mains supply is on!



WARNING!
Always switch off the mains voltage and wait at least 7 minutes to allow the DC capacitors to discharge before connecting the control signals or changing position of any switches. If the option External supply is used, switch of the mains to the option. This is done to prevent damage on the control board.

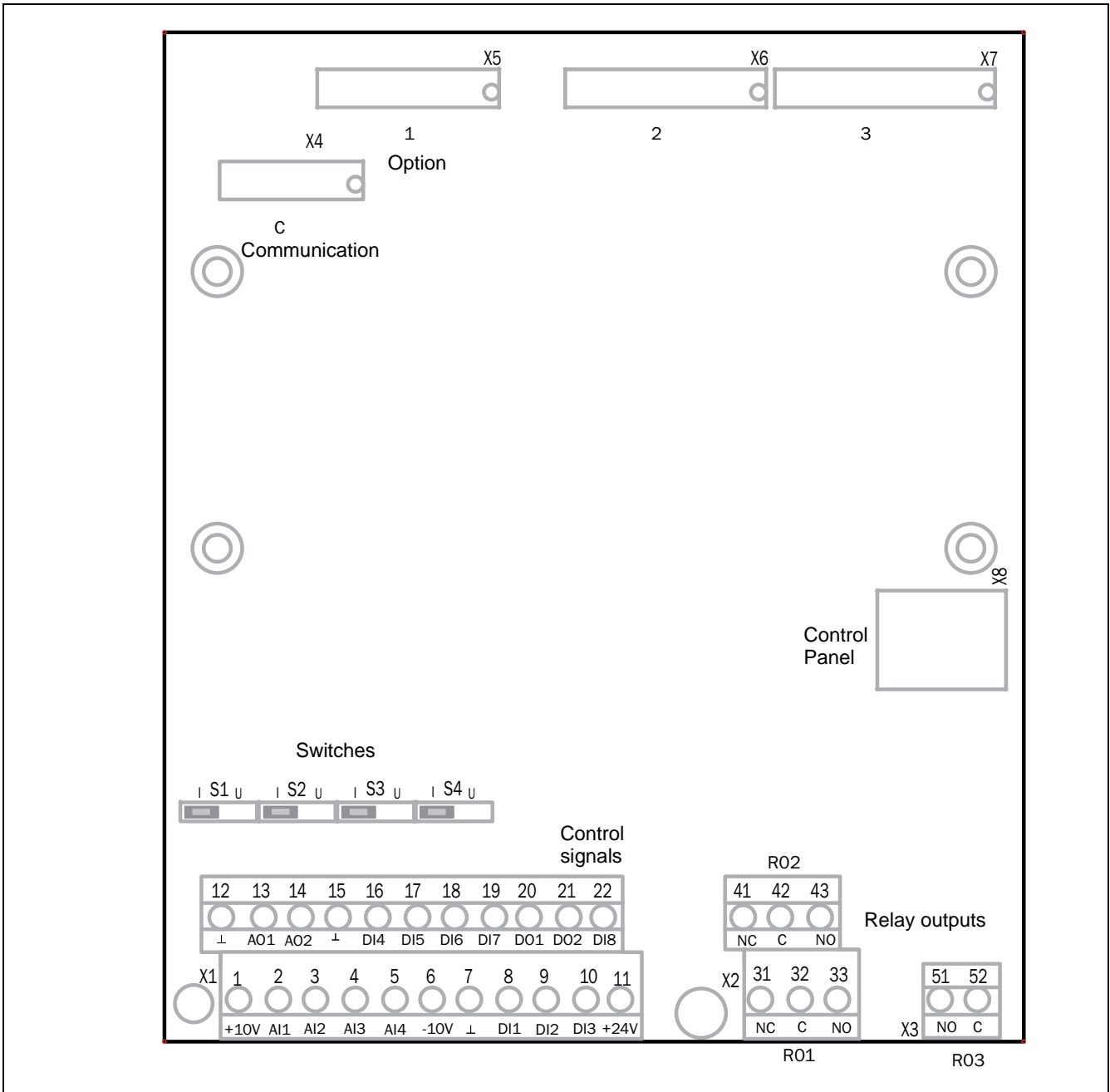

Fig. 30 Control board layout

4.2 Terminal connections

The terminal strip for connecting the control signals is accessible after opening the front panel.

The table describes the default functions for the signals. The inputs and outputs are programmable for other functions as described in chapter 11. page 63. For signal specifications refer to chapter 14. page 183.

NOTE: The maximum total combined current for outputs 11, 20 and 21 is 100mA.

NOTE: It is possible to use external 24V if connection to Common (15).

Table 14 Control signals

| Terminal | Name | Function (Default) |
|-------------------------|----------|------------------------|
| Outputs | | |
| 1 | +10 V | +10 VDC supply voltage |
| 6 | -10 V | -10 VDC supply voltage |
| 7 | Common | Signal ground |
| 11 | +24 V | +24 VDC supply voltage |
| 12 | Common | Signal ground |
| 15 | Common | Signal ground |
| Digital inputs | | |
| 8 | DigIn 1 | RunL (reverse) |
| 9 | DigIn 2 | RunR (forward) |
| 10 | DigIn 3 | Off |
| 16 | DigIn 4 | Off |
| 17 | DigIn 5 | Off |
| 18 | DigIn 6 | Off |
| 19 | DigIn 7 | Off |
| 22 | DigIn 8 | RESET |
| Digital outputs | | |
| 20 | DigOut 1 | Ready |
| 21 | DigOut 2 | Brake |
| Analogue inputs | | |
| 2 | AnIn 1 | Process Ref |
| 3 | AnIn 2 | Off |
| 4 | AnIn 3 | Off |
| 5 | AnIn 4 | Off |
| Analogue outputs | | |
| 13 | AnOut 1 | Min speed to max speed |
| 14 | AnOut 2 | 0 to max torque |
| Relay outputs | | |

Table 14 Control signals









| Terminal | Name | Function (Default) |
|----------|-------|--|
| 31 | N/C 1 | Relay 1 output Trip, active when the AC drive is in a TRIP condition. |
| 32 | COM 1 | |
| 33 | N/O 1 | |
| 41 | N/C 2 | Relay 2 output Run, active when the AC drive is started. |
| 42 | COM 2 | |
| 43 | N/O 2 | |
| 51 | COM 3 | Relay 3 output Off |
| 52 | N/O 3 | |

NOTE: N/C is opened when the relay is active and N/O is closed when the relay is active.

4.3 Inputs configuration with the switches

The switches S1 to S4 are used to set the input configuration for the 4 analogue inputs AnIn1, AnIn2, AnIn3 and AnIn4 as described in table 15. See Fig. 30 for the location of the switches.

Table 15 Switch settings

| Input | Signal type | Switch |
|-------|-------------------|--|
| AnIn1 | Voltage | S1  |
| | Current (default) | S1  |
| AnIn2 | Voltage | S2  |
| | Current (default) | S2  |
| AnIn3 | Voltage | S3  |
| | Current (default) | S3  |
| AnIn4 | Voltage | S4  |
| | Current (default) | S4  |

NOTE: Scaling and offset of AnIn1 - AnIn4 can be configured using the software. See menus [512], [515], [518] and [51B] in section 11.5, page 123.

NOTE: the 2 analogue outputs AnOut 1 and AnOut 2 can be configured using the software. See menu [530] section 11.5.3, page 132

4.4 Connection example

Fig. 31 gives an overall view of a AC drive connection example.

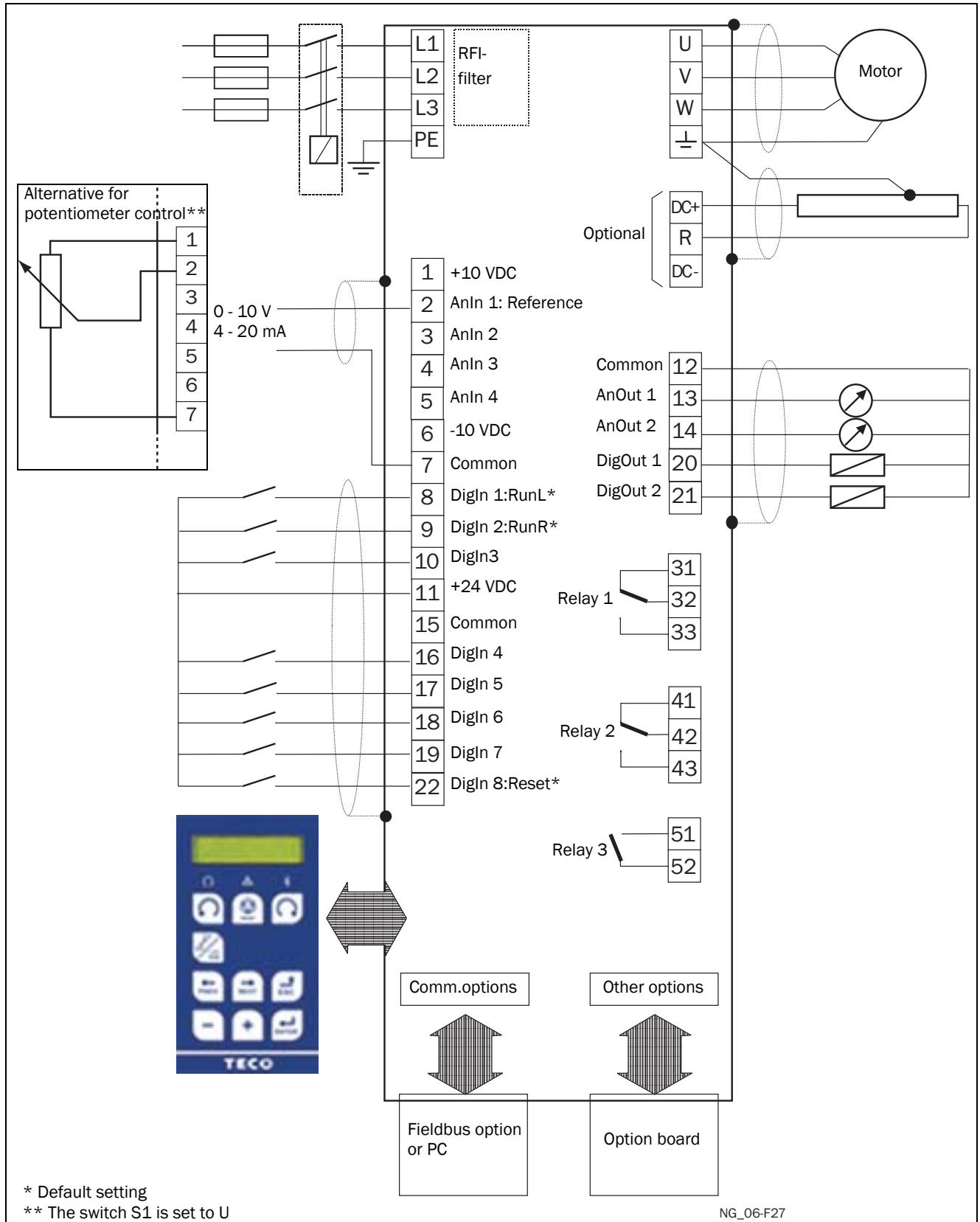

Fig. 31 Connection example

4.5 Connecting the Control Signals

4.5.1 Cables

The standard control signal connections are suitable for stranded flexible wire up to 1.5 mm² and for solid wire up to 2.5 mm².

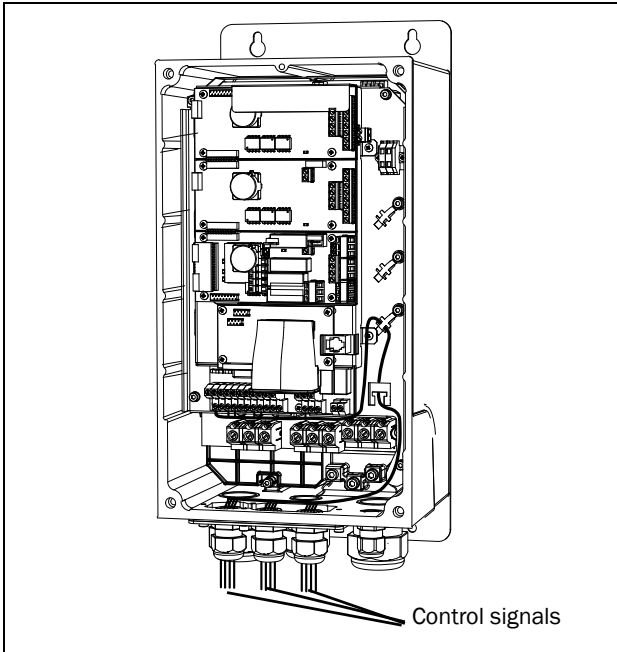

Fig. 32 Connecting the control signals, 0003 to 0018

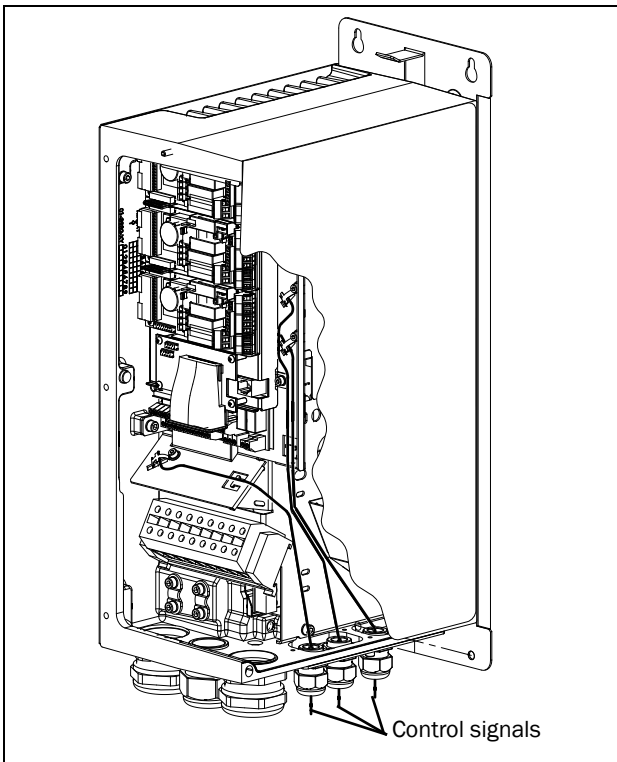

Fig. 33 Connecting the control signals, 0026 to 0046

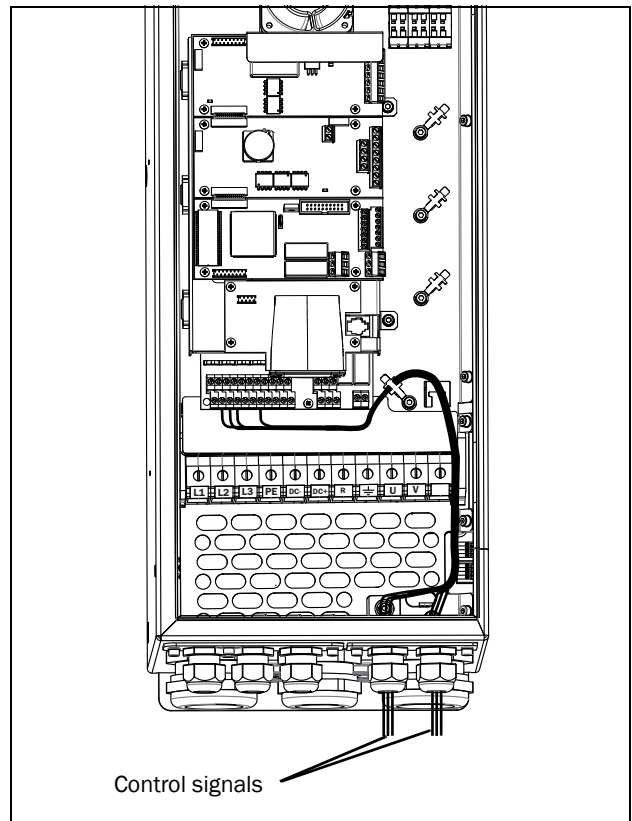

Fig. 34 Connecting the control signals, 0061 to 0074

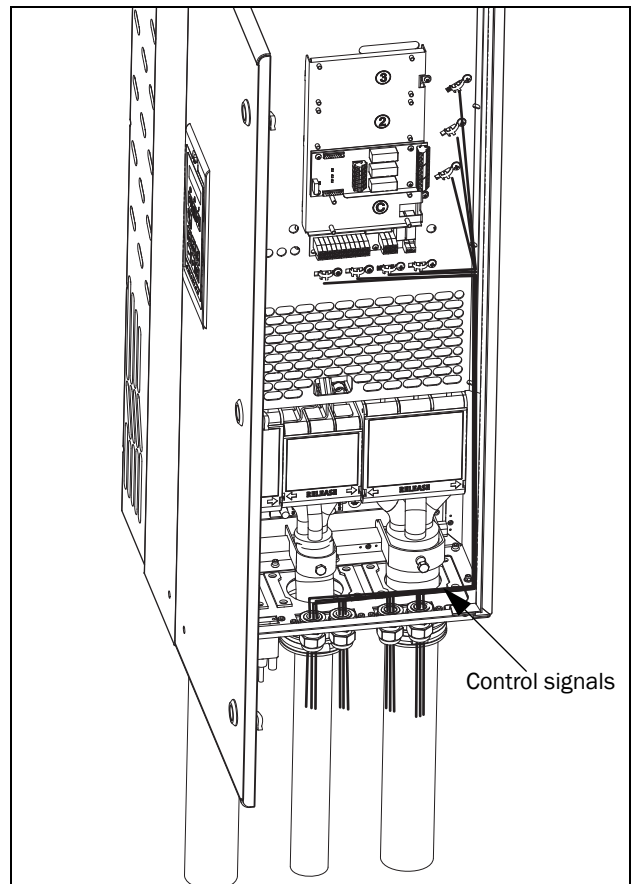

Fig. 35 Connecting the control signals, 0090 to 0250

NOTE: The screening of control signal cables is necessary to comply with the immunity levels given in the EMC Directive (it reduces the noise level).

NOTE: Control cables must be separated from motor and mains cables.

4.5.2 Types of control signals

Always make a distinction between the different types of signals. Because the different types of signals can adversely affect each other, use a separate cable for each type. This is often more practical because, for example, the cable from a pressure sensor may be connected directly to the AC drive.

We can distinguish between the following types of control signals:

Analogue inputs

Voltage or current signals, (0-10 V, 0/4-20 mA) normally used as control signals for speed, torque and PID feedback signals.

Analogue outputs

Voltage or current signals, (0-10 V, 0/4-20 mA) which change slowly or only occasionally in value. In general, these are control or measurement signals.

Digital

Voltage or current signals (0-10 V, 0-24 V, 0/4-20 mA) which can have only two values (high or low) and only occasionally change in value.

Data

Usually voltage signals (0-5 V, 0-10 V) which change rapidly and at a high frequency, generally data signals such as RS232, RS485, Profibus, etc.

Relay

Relay contacts (0-250 VAC) can switch highly inductive loads (auxiliary relay, lamp, valve, brake, etc.).

| Signal type | Maximum wire size | Tightening torque | Cable type |
|-------------|---|-------------------|--------------|
| Analogue | Rigid cable: 0.14-2.5 mm ² | 0.5 Nm | Screened |
| Digital | Flexible cable: 0.14-1.5 mm ² | | Screened |
| Data | Cable with ferrule: 0.25-1.5 mm ² | | Screened |
| Relay | | | Not screened |

Example:

The relay output from a AC drive which controls an auxiliary relay can, at the moment of switching, form a source of interference (emission) for a measurement signal from, for example, a pressure sensor. Therefore

it is advised to separate wiring and screening to reduce disturbances.

4.5.3 Screening

For all signal cables the best results are obtained if the screening is connected to both ends: the AC drive side and the at the source (e.g. PLC, or computer). See Fig. 36.

It is strongly recommended that the signal cables be allowed to cross mains and motor cables at a 90° angle. Do not let the signal cable go in parallel with the mains and motor cable.

4.5.4 Single-ended or double-ended connection?

In principle, the same measures applied to motor cables must be applied to all control signal cables, in accordance with the EMC-Directives.

For all signal cables as mentioned in section 4.5.2 the best results are obtained if the screening is connected to both ends. See Fig. 36.

NOTE: Each installation must be examined carefully before applying the proper EMC measurements.

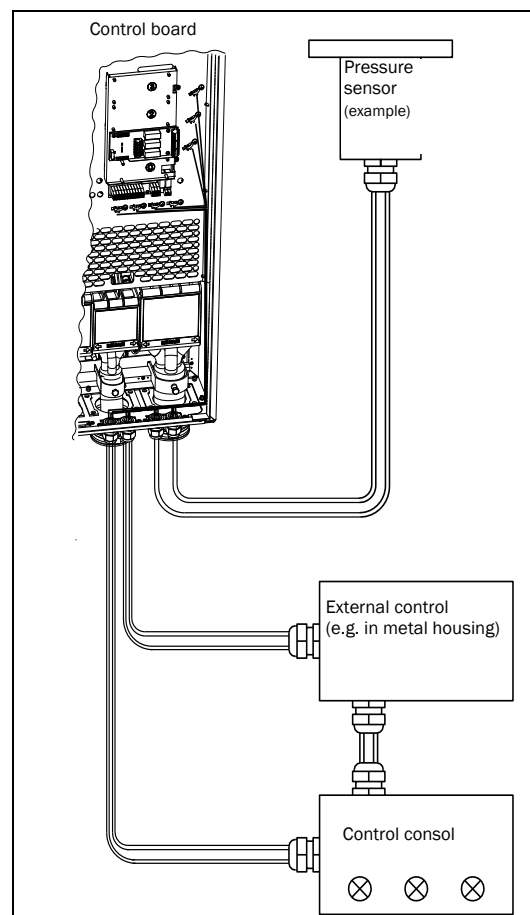

Fig. 36 Electro Magnetic (EM) screening of control signal cables.

4.5.5 Current signals ((0)4-20 mA)

A current signal like (0)4-20 mA is less sensitive to disturbances than a 0-10 V signal, because it is connected to an input which has a lower impedance (250 Ω) than a voltage signal (20 k Ω). It is therefore strongly advised to use current control signals if the cables are longer than a few metres.

4.5.6 Twisted cables

Analogue and digital signals are less sensitive to interference if the cables carrying them are “twisted”. This is certainly to be recommended if screening cannot be used. By twisting the wires the exposed areas are minimised. This means that in the current circuit for any possible High Frequency (HF) interference fields, no voltage can be induced. For a PLC it is therefore important that the return wire remains in proximity to the signal wire. It is important that the pair of wires is fully twisted over 360°.

4.6 Connecting options

The option cards are connected by the optional connectors X4 or X5 on the control board see Fig. 30, page 23 and mounted above the control board. The inputs and outputs of the option cards are connected in the same way as other control signals.

5. Getting Started

This chapter is a step by step guide that will show you the quickest way to get the motor shaft turning. We will show you two examples, remote control and local control.

We assume that the AC drive is mounted on a wall or in a cabinet as in the chapter 2. page 9.

First there is general information of how to connect mains, motor and control cables. The next section describes how to use the function keys on the control panel. The subsequent examples covering remote control and local control describe how to program/set the motor data and run the AC drive and motor.

5.1 Connect the mains and motor cables

Dimension the mains and motor cables according to local regulations. The cable must be able to carry the AC drive load current.

5.1.1 Mains cables

1. Connect the mains cables as in Fig. 37. The AC drive has, as standard, a built-in RFI mains filter that complies with category C3 which suits the Second Environment standard.

5.1.2 Motor cables

2. Connect the motor cables as in Fig. 37. To comply with the EMC Directive you have to use screened cables and the motor cable screen has to be connected on both sides: to the housing of the motor and the housing of the AC drive.

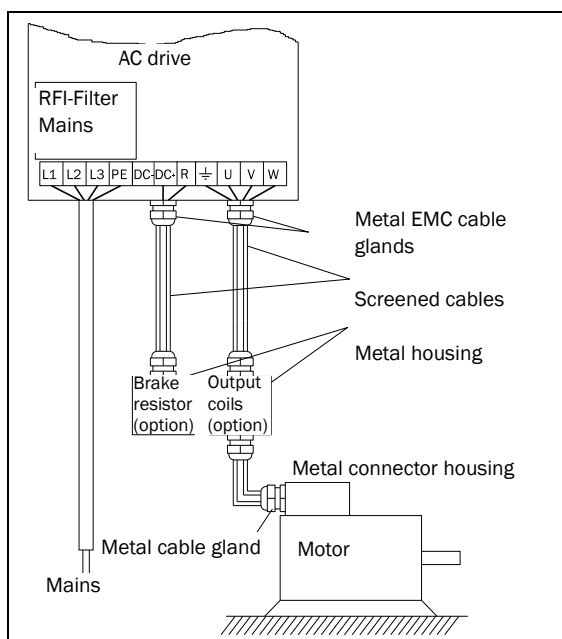

Fig. 37 Connection of mains and motor cables

Table 16 Mains and motor connection

| | |
|--------------------|--|
| L1,L2,L3 PE | Mains supply, 3 -phase Safety earth |
| \perp U, V, W | Motor earth Motor output, 3-phase |



WARNING!

In order to work safely the mains earth must be connected to PE and the motor earth to



5.2 Using the function keys

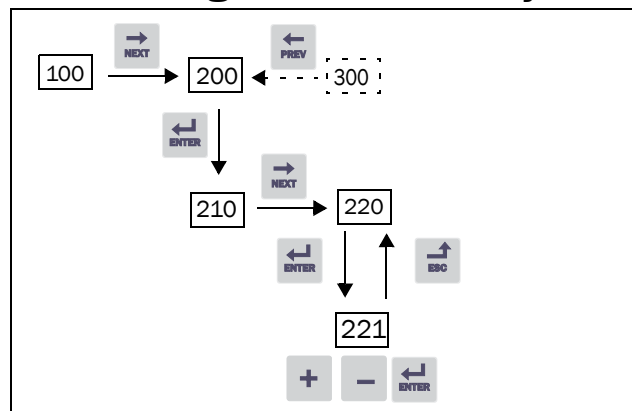

Fig. 38 Example of menu navigation when entering motor voltage



step to lower menu level or confirm changed setting



step to higher menu level or ignore changed setting



step to next menu on the same level



step to previous menu on the same level



increase value or change selection



decrease value or change selection

5.3 Remote control

In this example external signals are used to control the AC drive/motor.

A standard 4-pole motor for 400 V, an external start button and a reference value will also be used.

5.3.1 Connect control cables

Here you will make up the minimum wiring for starting. In this example the motor/AC drive will run with right rotation.

To comply with the EMC standard, use screened control cables with plaited flexible wire up to 1.5 mm² or solid wire up to 2.5 mm².

3. Connect a reference value between terminals 7 (Common) and 2 (AnIn 1) as in Fig. 39.
4. Connect an external start button between terminal 11 (+24 VDC) and 9 (DigIn2, RUNR) as in Fig. 39.

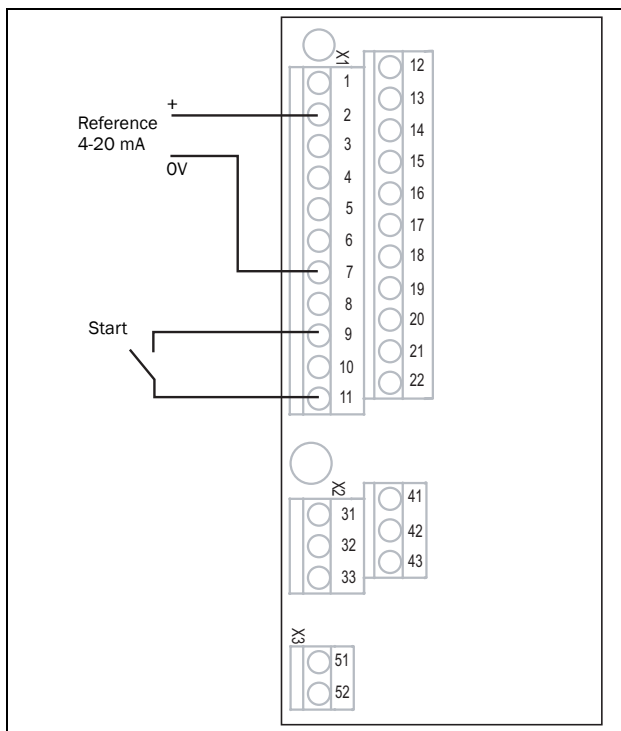

Fig. 39 Wiring

5.3.2 Switch on the mains

Close the door to the AC drive. Once the mains is switched on, the internal fan in the AC drive will run for 5 seconds.

5.3.3 Set the Motor Data

Enter correct motor data for the connected motor. The motor data is used in the calculation of complete operational data in the AC drive.

Change settings using the keys on the control panel. For

further information about the control panel and menu structure, see the chapter 9. page 53.

Menu [100], Preferred View is displayed when started.

1. Press to display menu [200], Main Setup.
2. Press and then to display menu [220], Motor Data.
3. Press to display menu [221] and set motor voltage.
4. Change the value using the and keys. Confirm with .
5. Set motor frequency [222].
6. Set motor power [223].
7. Set motor current [224].
8. Set motor speed [225].
9. Set power factor (cos j) [227].
10. Select supply voltage level used [21B]
11. [229] Motor ID run: Choose Short, confirm with and give start command .

The AC drive will now measure some motor parameters. The motor makes some beeping sounds but the shaft does not rotate. When the ID run is finished after about one minute ("Test Run OK!" is displayed), press to continue.

12. Use AnIn1 as input for the reference value. The default range is 4-20 mA. If you need a 0-10 V reference value, change switch (S1) on control board and set [512] AnIn 1 Set-up to 0-10V.
13. Switch off power supply.
14. Connect digital and analogue inputs/outputs as in Fig. 39.
15. Ready!
16. Switch on power supply.

5.3.4 Run the AC drive

Now the installation is finished, and you can press the external start button to start the motor.

When the motor is running the main connections are OK.

5.4 Local control

Manual control via the control panel can be used to carry out a test run.











Use a 400 V motor and the control panel.

5.4.1 Switch on the mains

Close the door to the AC drive. Once the mains is switched on, the AC drive is started and the internal fan will run for 5 seconds.







5.4.2 Select manual control

Menu [100], Preferred View is displayed when started.

1. Press  to display menu [200], Main Setup.
2. Press  to display menu [210], Operation.
3. Press  to display menu [211], Language.
4. Press  to display menu [214], Reference Control.
5. Select **Keyboard** using the key  and press  to confirm.
6. Press  to get to menu [215], Run/Stop Control.
7. Select **Keyboard** using the key  and press  to confirm.
8. Press  to get to previous menu level and then  to display menu [220], Motor Data.





5.4.3 Set the Motor Data

Enter correct motor data for the connected motor.

9. Press  to display menu [221].
10. Change the value using the  and  keys. Confirm with .
11. Press  to display menu [222].
12. Repeat step 9 and 10 until all motor data is entered.
13. Press  twice and then  to display menu [100], Preferred View.

5.4.4 Enter a Reference Value

Enter a reference value.

14. Press  until menu [300], Process is displayed.
15. Press  to display menu [310], Set/View reference value.
16. Use the  and  keys to enter, for example, 300 rpm. We select a low value to check the rotation direction without damaging the application.

5.4.5 Run the AC drive

Press the  key on the control panel to run the motor forward.

If the motor is running the main connections are OK.

6. Applications

This chapter contains tables giving an overview of many different applications/duties in which it is suitable to use the AC drives. Further on you will find application examples of the most common applications and solutions.

6.1 Application overview

6.1.1 Cranes

| Challenge | V33 solution | Menu |
|---|---|--------------------|
| Starting with heavy load is difficult and risky. Can lead to jerks causing swinging load. | Direct torque control, fast motor pre-magnetization and precise brake control gives instant yet soft start with heavy load. | 331-338, 339, 351 |
| Jerky movements can cause load to be dropped, jeopardizing safety of people and goods. | Deviation control immediately detects load change. Signals to parallel safety system to activate mechanical brakes. | 3AB, 3AC |
| Crane is driven slowly when returning empty or with light load. Valuable time is lost. | Speed can be increased by field weakening. | 343, 3AA, 3AD, 713 |
| Braking with heavy load is difficult and risky. Can lead to jerks causing swinging load. | Direct torque control and vector brake gradually reduce speed to zero before mechanical brake is activated. | 213, 33E, 33F, 33G |
| Operator starts braking long before end position to avoid jerks. Valuable time is lost. | System automatically stops crane at end position. Operator can safely drive at full speed. | 3A2-3AA |

6.1.2 Crushers

| Challenge | V33 solution | Menu |
|--|---|--------------------|
| High start currents require larger fuses and cables, or for mobile crushers larger diesel generators. | Direct torque control reduces start current. Same fuses as those for the motor, or smaller generator. | 331-338, 351 |
| Difficult to start with heavy load. | Possible to boost torque at start to overcome initial torque peak. | 351-353 |
| Material that could cause damage gets into the crusher. | Load Curve Protection quickly detects deviation. Warning is sent or safety stop activated. | 411-41C9 |
| Process inefficiency due to e.g. broken feeder or worn jaw. Wasted energy, mechanical stress, and risk of process failure. | Load Curve Protection quickly detects deviation from normal load. Warning is sent or safety stop activated. | 411-41B, 41C1-41C9 |

7. Main Features

This chapter contains descriptions of the main features of the AC drive.

7.1 Parameter sets

Parameter sets are used if an application requires different settings for different modes. For example, a machine can be used for producing different products and thus requires two or more maximum speeds and acceleration/deceleration times. With the four parameter sets different control options can be configured with respect to quickly changing the behaviour of the AC drive. It is possible to adapt the AC drive online to altered machine behaviour. This is based on the fact that at any desired moment any one of the four parameter sets can be activated during Run or Stop, via the digital inputs or the control panel and menu [241].

Each parameter set can be selected externally via a digital input. Parameter sets can be changed during operation and stored in the control panel.

NOTE: The only data not included in the parameter set is Motor data 1-4, (entered separately), language, communication settings, selected set, local remote, and keyboard locked.

Define parameter sets

When using parameter sets you first decide how to select different parameter sets. The parameter sets can be selected via the control panel, via digital inputs or via serial communication. All digital inputs and virtual inputs can be configured to select parameter set. The function of the digital inputs is defined in the menu [520].

Fig. 40 shows the way the parameter sets are activated via any digital input configured to Set Ctrl 1 or Set Ctrl 2.

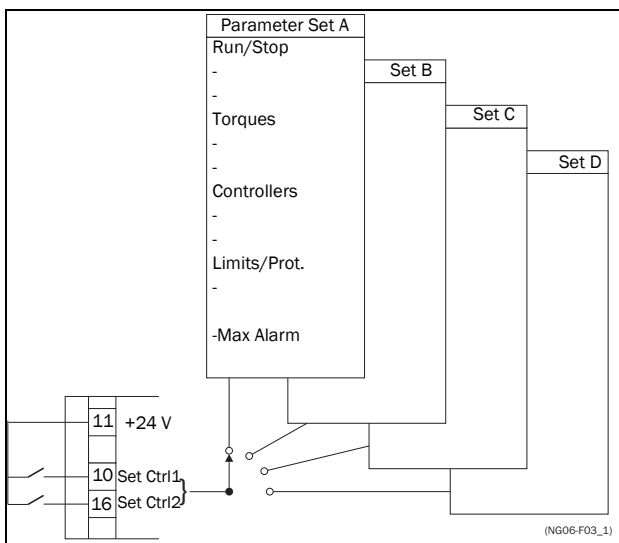

Fig. 40 Selecting the parameter sets

Select and copy parameter set

The parameter set selection is done in menu [241], Select Set. First select the main set in menu [241], normally A. Adjust all settings for the application. Usually most parameters are common and therefore it saves a lot of work by copying set A>B in menu [242]. When parameter set A is copied to set B you only change the parameters in the set that need to be changed. Repeat for C and D if used.

With menu [242], Copy Set, it is easy to copy the complete contents of a single parameter set to another parameter set. If, for example, the parameter sets are selected via digital inputs, DigIn 3 is set to Set Ctrl 1 in menu [523] and DigIn 4 is set to Set Ctrl 2 in menu [524], they are activated as in Table 17.

Activate the parameter changes via digital input by setting menu [241], Select Set to DigIn.

Table 17 Parameter set

| Parameter set | Set Ctrl 1 | Set Ctrl 2 |
|---------------|------------|------------|
| A | 0 | 0 |
| B | 1 | 0 |
| C | 0 | 1 |
| D | 1 | 1 |

NOTE: The selection via the digital inputs is immediately activated. The new parameter settings will be activated on-line, also during Run.

NOTE: The default parameter set is parameter set A.

Examples

Different parameter sets can be used to easily change the setup of a AC drive to adapt quickly to different application requirements. For example when

- a process needs optimized settings in different stages of the process, to
 - increase the process quality
 - increase control accuracy
 - lower maintenance costs
 - increase operator safety

With these settings a large number of options are available. Some ideas are given here:

Multi frequency selection

Within a single parameter set the 7 preset references can be selected via the digital inputs. In combination with the parameter sets, 28 preset references can be selected using all 4 digital inputs: DigIn1, 2 and 3 for selecting preset reference within one parameter set

and DigIn 4 and DigIn 5 for selecting the parameter sets.

Bottling machine with 3 different products

Use 3 parameter sets for 3 different Jog reference speeds when the machine needs to be set up. The 4th parameter set can be used for “normal” remote control when the machine is running at full production.

Product changing on winding machines

If a machine has to change between 2 or 3 different products e.g. winding machine with different gauges of thread, it is important that acceleration, deceleration times, Max Speed and Max Torque are adapted. For each thread size a different parameter set can be used.

Manual - automatic control

If in an application something is filled up manually and then the level is automatically controlled using PID regulation, this is solved using one parameter set for the manual control and one for the automatic control.

7.1.1 One motor and one parameter set

This is the most common application for pumps and fans.

Once default motor M1 and parameter set A have been selected:

1. Enter the settings for motor data.
2. Enter the settings for other parameters e.g. inputs and outputs

7.1.2 One motor and two parameter sets

This application is useful if you for example have a machine running at two different speeds for different products.

Once default motor M1 is selected:

1. Select parameter set A in menu [241].
2. Enter motor data in menu [220].
3. Enter the settings for other parameters e.g. inputs and outputs.
4. If there are only minor differences between the settings in the parameter sets, you can copy parameter set A to parameter set B, menu [242].
5. Enter the settings for parameters e.g. inputs and outputs.

Note: Do not change motor data in parameter set B.

7.1.3 Two motors and two parameter sets

This is useful if you have a machine with two motors that can not run at the same time, such as a cable winding machine that lifts up the reel with one motor and then turns the wheel with the other motor.

One motor must stop before changing to an other motor.

1. Select parameter set A in menu [241].
2. Select motor M1 in menu [212].
3. Enter motor data and settings for other parameters e.g. inputs and outputs.
4. Select parameter set B in menu [241].
5. Select M2 in menu [212].
6. Enter motor data and settings for other parameters e.g. inputs and outputs.

7.1.4 Autoreset at trip

For several non-critical application-related failure conditions, it is possible to automatically generate a reset command to overcome the fault condition. The selection can be made in menu [250]. In this menu the maximum number of automatically generated restarts allowed can be set, see menu [251], after this the AC drive will stay in fault condition because external assistance is required.

Example

The motor is protected by an internal protection for thermal overload. When this protection is activated, the AC drive should wait until the motor is cooled down enough before resuming normal operation. When this problem occurs three times in a short period of time, external assistance is required.

The following settings should be applied:

- Insert maximum number of restarts; set menu [251] to 3.
- Activate Motor I²t to be automatically reset; set menu [25A] to 300 s.
- Set relay 1, menu [551] to AutoRst Trip; a signal will be available when the maximum number of restarts is reached and the AC drive stays in fault condition.
- The reset input must be constantly activated.

7.1.5 Reference priority

The active speed reference signal can be programmed from several sources and functions. The table below

shows the priority of the different functions with regards to the speed reference.

Table 18 Reference priority

| Jog Mode | Preset Reference | Motor Pot | Ref. Signal |
|----------|------------------|-----------|--------------------|
| On/Off | On/Off | On/Off | Option cards |
| On | On/Off | On/Off | Jog Ref |
| Off | On | On/Off | Preset Ref |
| Off | Off | On | Motor pot commands |

7.1.6 Preset references

The AC drive is able to select fixed speeds via the control of digital inputs. This can be used for situations where the required motor speed needs to be adapted to fixed values, according to certain process conditions. Up to 7 preset references can be set for each parameter set, which can be selected via all digital inputs that are set to Preset Ctrl1, Preset Ctrl2 or Preset Ctrl3. The amount digital inputs used that are set to Preset Ctrl determines the number of Preset References available; using 1 input gives 2 speeds, using 2 inputs gives 4 speeds and using 3 inputs gives 8 speeds.

Example

The use of four fixed speeds, at 50 / 100 / 300 / 800 rpm, requires the following settings:

- Set DigIn 5 as first selection input; set [525] to Preset Ctrl1.
- Set DigIn 6 as second selection input; set [526] to Preset Ctrl2.
- Set menu [341], Min Speed to 50 rpm.
- Set menu [362], Preset Ref 1 to 100 rpm.
- Set menu [363], Preset Ref 2 to 300 rpm.
- Set menu [364], Preset Ref 3 to 800 rpm.

With these settings, the AC drive switched on and a RUN command given, the speed will be:

- 50 rpm, when both DigIn 5 and DigIn 6 are low.
- 100 rpm, when DigIn 5 is high and DigIn 6 is low.
- 300 rpm, when DigIn 5 is low and DigIn 6 is high.
- 800 rpm, when both DigIn 5 and DigIn 6 are high.

7.2 Remote control functions

Operation of the Run/Stop/Enable/Reset functions

As default, all the run/stop/reset related commands are programmed for remote operation via the inputs on the terminal strip (terminals 1-22) on the control board. With the function Run/Stp Ctrl [215] and Reset Control [216], this can be selected for keyboard or serial communication control.

NOTE: The examples in this paragraph do not cover all possibilities. Only the most relevant combinations are given. The starting point is always the default setting (factory) of the AC drive.

Default settings of the Run/Stop/Enable/Reset functions

The default settings are shown in Fig. 41. In this example the AC drive is started and stopped with DigIn 2 and a reset after trip can be given with DigIn 8.

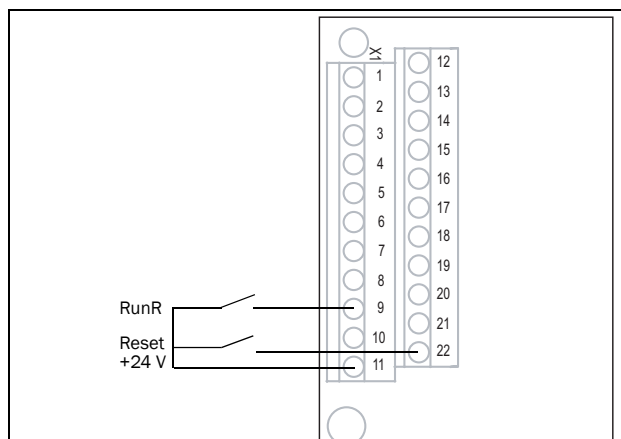

Fig. 41 Default setting Run/Reset commands

The inputs are default set for level-control. The rotation is determined by the setting of the digital inputs.

Enable and Stop functions

Both functions can be used separately or simultaneously. The choice of which function is to be used depends on the application and the control mode of the inputs (Level/Edge [21A]).

NOTE: In Edge mode, at least one digital input must be programmed to “stop”, because the Run commands are otherwise only able to start the AC drive.

Enable

Input must be active (HI) to allow any Run signal. If the input is made LOW, the output of the AC drive is immediately disabled and the motor will coast.



CAUTION!
If the Enable function is not programmed to a digital input, it is considered to be active internally.

Stop

If the input is low then the AC drive will stop according to the selected stop mode set in menu [33B] Stop Mode. Fig. 42 shows the function of the Enable and the Stop input and the Stop Mode=Decel [33B].

To run the input must be high.

NOTE: Stop Mode=Coast [33B] will give the same behaviour as the Enable input.

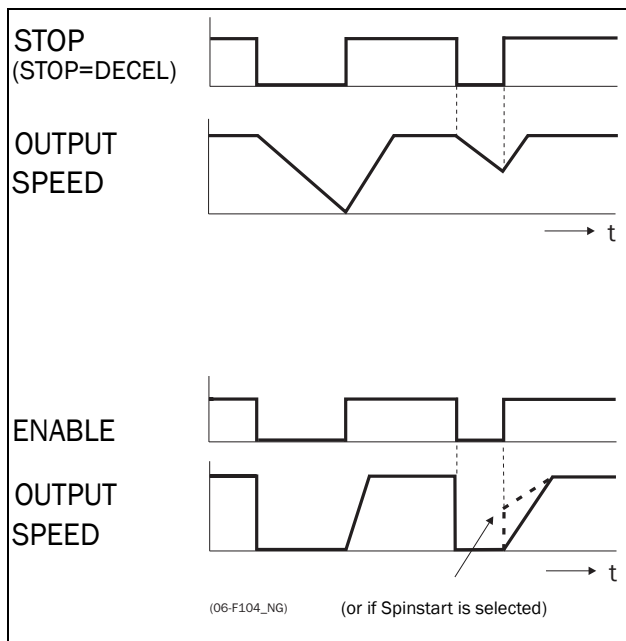

Fig. 42 Functionality of the Stop and Enable input

Reset and Autoreset operation

If the AC drive is in Stop Mode due to a trip condition, the AC drive can be remotely reset by a pulse (“low” to “high” transition) on the Reset input, default on DigIn 8. Depending on the selected control method, a restart takes place as follows:

Level-control

If the Run inputs remain in their position the AC drive will start immediately after the Reset command is given.

Edge-control

After the Reset command is given a new Run command must be applied to start the AC drive again.

Autoreset is enabled if the Reset input is continuously active. The Autoreset functions are programmed in menu Autoreset [250].

NOTE: If the control commands are programmed for Keyboard control or Com, Autoreset is not possible.

Run Inputs Level-controlled.

The inputs are set as default for level-control. This means that an input is activated by making the input continuously “High”. This method is commonly used if, for example, PLCs are used to operate the AC drive.



CAUTION!
Level-controlled inputs **DO NOT** comply with the Machine Directive, if the inputs are directly used to start and stop the machine.

The examples given in this and the following paragraphs follow the input selection shown in Fig. 43.

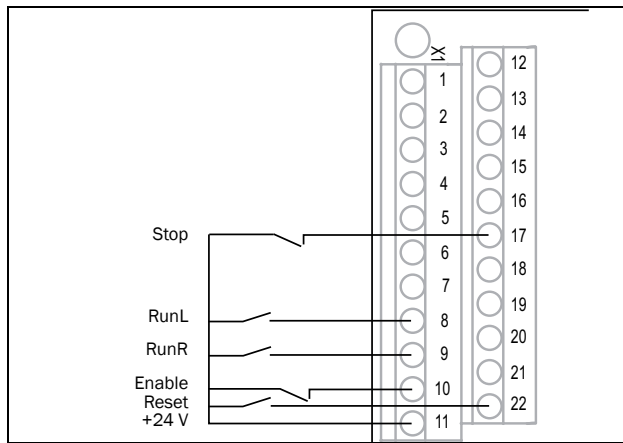

Fig. 43 Example of wiring for Run/Stop/Enable/Reset inputs

The Enable input must be continuously active in order to accept any run-right or run-left command. If both RunR and RunL inputs are active, then the AC drive stops according to the selected Stop Mode. Fig. 44 gives an example of a possible sequence.

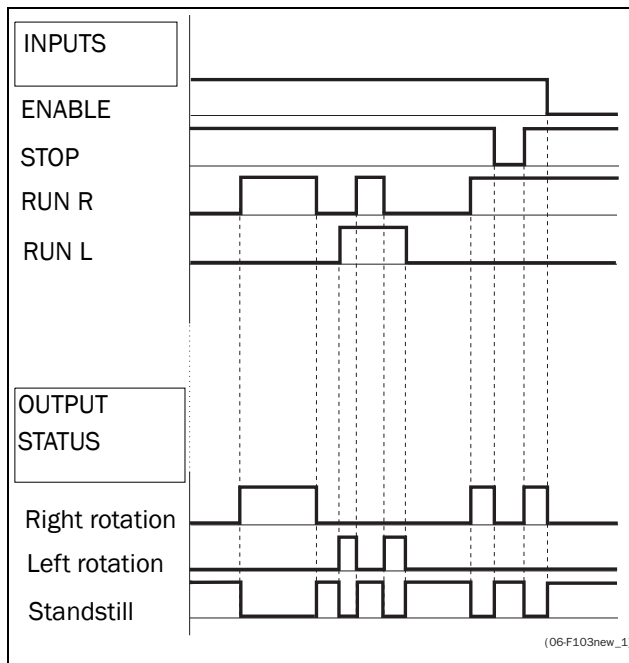

Fig. 44 Input and output status for level-control

Run Inputs Edge-controlled

Menu [21A] Start signal Level/Edge must be set to Edge to activate edge control. This means that an input is activated by a “low” to “high” transition or vice versa.

NOTE: Edge-controlled inputs comply with the Machine Directive (see chapter EMC and Machine Directive), if the inputs are directly used for starting and stopping the machine.

See Fig. 43. The Enable and Stop input must be active continuously in order to accept any run-right or run-left command. The last edge (RunR or RunL) is valid. Fig. 45 gives an example of a possible sequence.

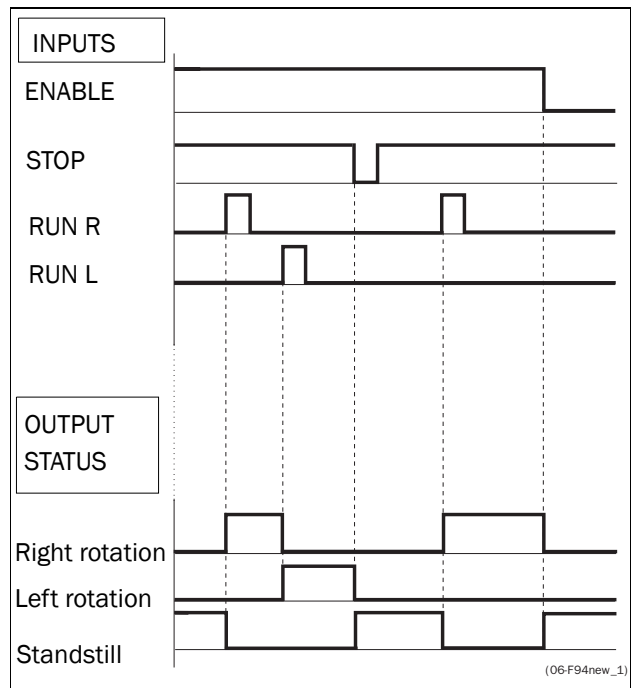

Fig. 45 Input and output status for edge-control

7.3 Performing an Identification Run

To get the optimum performance out of your AC drive/motor combination, the AC drive must measure the electrical parameters (resistance of stator winding, etc.) of the connected motor. See menu [229], Motor ID-Run.

It is recommended that the extended ID run be used before the motor is installed in the application.

If this is not possible, the short ID run should be used.



WARNING!

During the extended ID RUN, the motor shaft will rotate. Take safety measures to avoid unforeseen dangerous situations.

7.4 Using the Control Panel Memory

Data can be copied from the AC drive to the memory in the control panel and vice versa. To copy all data (including parameter set A-D and motor data) from the AC drive to the control panel, select Copy to CP[244], Copy to CP.

To copy data from the control panel to the AC drive, enter the menu [245], Load from CP and select what you want to copy.

The memory in the control panel is useful in applications with VSDs without a control panel and in applications where several AC drives have the same setup. It can also be used for temporary storage of settings. Use a control panel to upload the settings from one AC drive and then move the control panel to another AC drive and download the settings.

NOTE: Load from and copy to the AC drive is only possible when the AC drive is in stop mode.

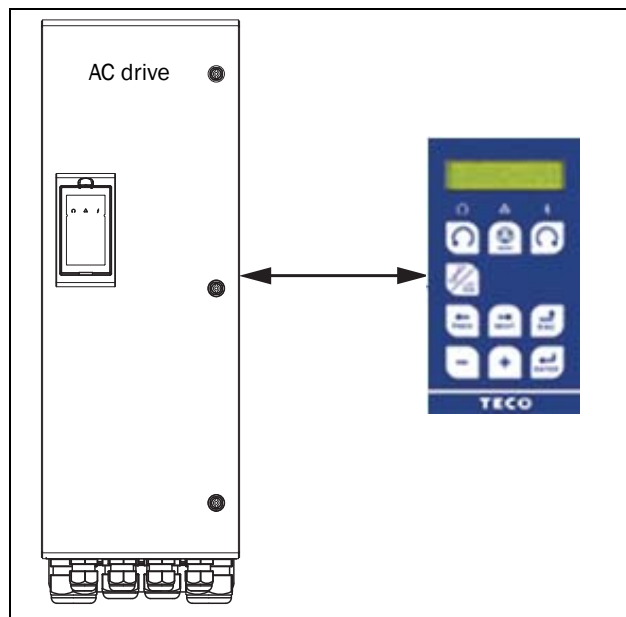

Fig. 46 Copy and load parameters between AC drive and control panel

7.5 Load Monitor and Process Protection [400]

7.5.1 Load Monitor [410]

The monitor functions enable the AC drive to be used as a load monitor. Load monitors are used to protect machines and processes against mechanical overload and underload, such as a conveyer belt or screw conveyer jamming, belt failure on a fan or a pump dry running. The load is measured in the AC drive by the calculated motor shaft torque. There is an overload alarm (Max Alarm and Max Pre-Alarm) and an underload alarm (Min Alarm and Min Pre-Alarm).

The Basic Monitor type uses fixed levels for overload and underload (pre-)alarms over the whole speed range. This function can be used in constant load applications where the torque is not dependent on the speed, e.g. conveyor belt, displacement pump, screw pump, etc.

For applications with a torque that is dependent on the speed, the Load Curve monitor type is preferred. By measuring the actual load curve of the process, characteristically over the range of minimum speed to maximum speed, an accurate protection at any speed can be established.

The max and min alarm can be set for a trip condition. The pre-alarms act as a warning condition. All the alarms can be monitored on the digital or relay outputs.

The autoset function automatically sets the 4 alarm levels whilst running: maximum alarm, maximum pre-alarm, minimum alarm and minimum pre-alarm.

Fig. 47 gives an example of the monitor functions for constant torque applications

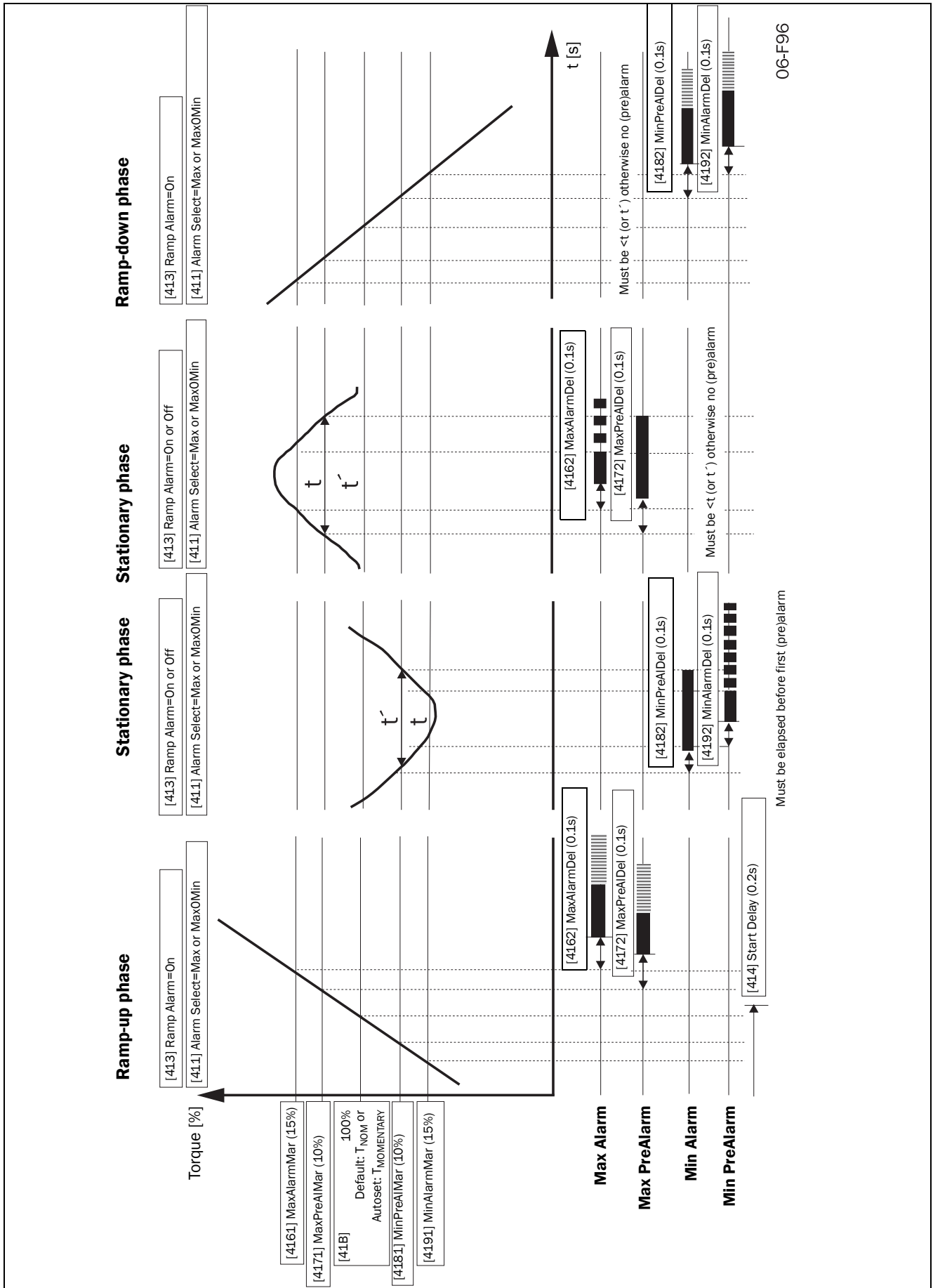

Fig. 47

8. EMC and Machine Directive

8.1 EMC standards

The AC drive complies with the following standards:

EN(IEC)61800-3:2004 Adjustable speed electronic power drive systems, part 3, EMC product standards:

Standard: category C3, for systems of rated supply voltage < 1000 VAC, intended for use in the second environment.

Optional: Category C2, for systems of rated supply voltage < 1.000 V, which is neither a plug in device nor a movable device and, when used in the first environment, is intended to be installed and commissioned only by experienced person with the necessary skills in installing and/or commissioning AC drives including their EMC aspects.

8.2 Stop categories and emergency stop

The following information is important if emergency stop circuits are used or needed in the installation where a AC drive is used. EN 60204-1 defines 3 stop categories:

Category 0: Uncontrolled STOP:

Stopping by switching off the supply voltage. A mechanical stop must be activated. This STOP may not be implemented with the help of a AC drive or its input/output signals.

Category 1: Controlled STOP:

Stopping until the motor has come to rest, after which the mains supply is switched off. This STOP may not be implemented with the help of a AC drive or its input/output signals.

Category 2: Controlled STOP:

Stopping while the supply voltage is still present. This STOP can be implemented with each of the AC drives STOP command.



WARNING!

EN 60204-1 specifies that every machine must be provided with a category 0 stop. If the application prevents this from being implemented, this must be explicitly stated. Furthermore, every machine must be provided with an Emergency Stop function. This emergency stop must ensure that the voltage at the machine contacts, which could be dangerous, is removed as quickly as possible, without resulting in any other danger. In such an Emergency Stop situation, a category 0 or 1 stop may be used. The choice will be decided on the basis of the possible risks to the machine.

NOTE: With option Safe Stop, a "Safe Torque Off (STO)" stop according EN-IEC 62061:2005 SIL 2 & EN-ISO 13849-1:2006, can be achieved. See chapter 13.10 page 179

9. Operation via the Control Panel

This chapter describes how to use the control panel. The AC drive can be delivered with a control panel or a blank panel.

9.1 General

The control panel displays the status of the AC drive and is used to set all the parameters. It is also possible to control the motor directly from the control panel. The control panel can be built-in or located externally via serial communication. The AC drive can be ordered without the control panel. Instead of the control panel there will be a blank panel.

NOTE: The AC drive can run without the control panel being connected. However the settings must be such that all control signals are set for external use.

9.2 The control panel

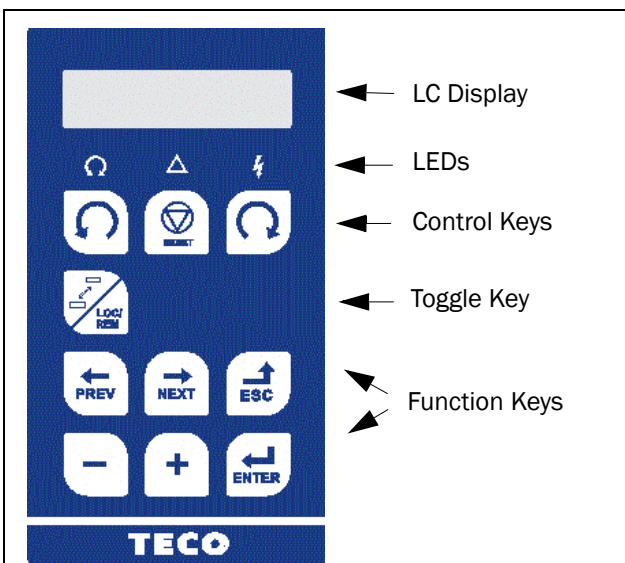

Fig. 48 Control panel

9.2.1 The display

The display is back lit and consists of 2 rows, each with space for 16 characters. The display is divided into six areas.

The different areas in the display are described below:

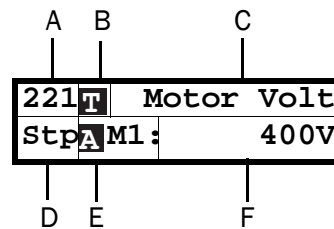

Fig. 49 The display

- Area A: Shows the actual menu number (3 or 4 digits).
- Area B: Shows if the menu is in the toggle loop or the AC drive is set for Local operation.
- Area C: Shows the heading of the active menu.
- Area D: Shows the status of the AC drive (3 digits). The following status indications are possible:
 - Acc** : Acceleration
 - Dec** : Deceleration
 - I²t** : Active I²t protection
 - Run** : Motor runs
 - Trp** : Tripped
 - Stp** : Motor is stopped
 - VL** : Operating at Voltage limit
 - SL** : Operating at Speed limit
 - CL** : Operating at Current limit
 - TL** : Operating at Torque limit
 - OT** : Operating at Temperature Limit
 - LV** : Operating at Low Voltage
 - Sby** : Operating from Standby power supply
 - SST** : Operating Safe Stop, is flashing when activated
 - LCL** : Operating with low cooling liquid level
- Area E: Shows active parameter set and if it is a motor parameter.
- Area F: Shows the setting or selection in the active menu. This area is empty at the 1st level and 2nd level menu. This area also shows warnings and alarm messages. In some situations this area could indicate +++ or --- please see further information in chapter 9.2.2 page 46



Fig. 50 Example 1st level menu

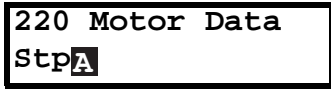

Fig. 51 Example 2nd level menu

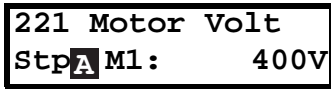

Fig. 52 Example 3rd level menu

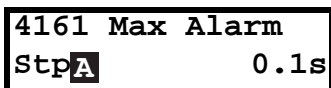

Fig. 53 Example 4th level menu

9.2.2 Indications on the display

The display can indicate +++ or --- if a parameter is out of range. In the AC drive there are parameters which are dependent on other parameters. For example, if the speed reference is 500 and the maximum speed value is set to a value below 500, this will be indicated with +++ on the display. If the minimum speed value is set over 500, --- is displayed.

9.2.3 LED indicators

The symbols on the control panel have the following functions:

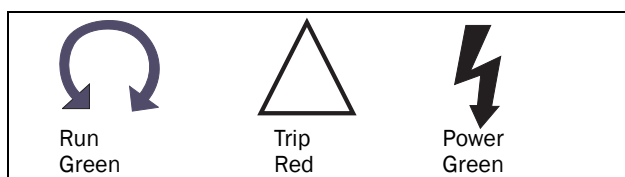

Fig. 54 LED indications

Table 19 LED indication

| Symbol | Function | | |
|----------------------|------------------|---------------|-----------|
| | ON | FLASHING | OFF |
| POWER (green) | Power on | ----- | Power off |
| TRIP (red) | AC drive tripped | Warning/Limit | No trip |

Table 19 LED indication

| RUN (green) | Motor shaft rotates | Motor speed increase/decrease | Motor stopped |
|--------------------|---------------------|-------------------------------|---------------|
| | | | |



NOTE: If the control panel is built in, the back light of the display has the same function as the Power LED in Table 19 (Blank panel LEDs).

9.2.4 Control keys

The control keys are used to give the Run, Stop or Reset commands directly. As default these keys are disabled, set for remote control. Activate the control keys by selecting Keyboard in the menu Ref Control [214] and Reset Ctrl [216].

If the Enable function is programmed on one of the digital inputs, this input must be active to allow Run/Stop commands from the control panel.

Table 20 Control keys

| | | |
|---|-------------|---|
|  | RUN L: | gives a start with left rotation |
|  | STOP/RESET: | stops the motor or resets the AC drive after a trip |
|  | RUN R: | gives a start with right rotation |

NOTE: It is not possible to simultaneously activate the Run/Stop commands from the keyboard and remotely from the terminal strip (terminals 1-22).

9.2.5 The Toggle and Loc/Rem Key

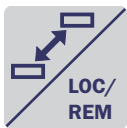

This key has two functions: Toggle and switching between Loc/Rem function.

Press one second to use the toggle function

Press and hold the toggle key for more than five seconds to switch between Local and Remote function, depending on the settings in [2171] and [2172].

When editing values, the toggle key can be used to change the sign of the value, see section 9.5, page 49.

Toggle function

Using the toggle function makes it possible to easily step through selected menus in a loop. The toggle loop can contain a maximum of ten menus. As default the toggle loop contains the menus needed for Quick Setup. You can use the toggle loop to create a quick-menu for the parameters that are most importance to your specific application.

NOTE: Do not keep the Toggle key pressed for more than five seconds without pressing either the +, - or Esc key, as this may activate the Loc/Rem function of this key instead. See menu [217].

Add a menu to the toggle loop

1. Go to the menu you want to add to the loop.
2. Press the Toggle key and keep it pressed while pressing the + key.

Delete a menu from the toggle loop

1. Go to the menu you want to delete using the toggle key.
2. Press the Toggle key and keep it pressed while pressing the - key.

Delete all menus from the toggle loop

1. Press the Toggle key and keep it pressed while pressing the Esc key.
2. Confirm with Enter. The menu Preferred view [100] is displayed.

Default toggle loop

Fig. 55 shows the default toggle loop. This loop contains the necessary menus that need to be set before starting. Press Toggle to enter menu [211] then use the Next key to enter the sub menus [212] to [21A] and enter the parameters. When you press the Toggle key again, menu [221] is displayed.

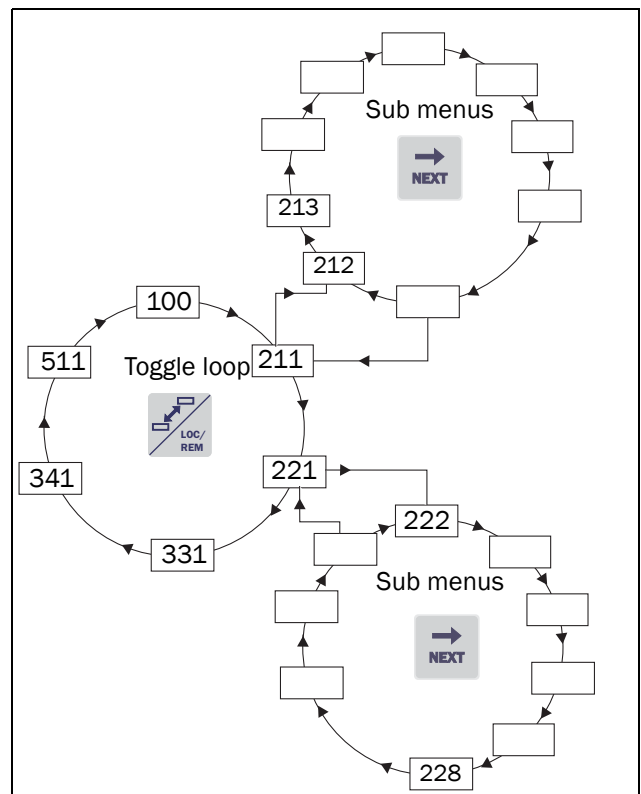



Fig. 55 Default toggle loop

Indication of menus in toggle loop

Menus included in the toggle loop are indicated with a  in area B in the display.

Loc/Rem function

The Loc/Rem function of this key is disabled as default. Enable the function in menu [2171] and/or [2172].

With the function Loc/Rem you can change between local and remote control of the AC drive from the control panel. The function Loc/Rem can also be changed via the DigIn, see menu Digital inputs [520]

Change control mode

1. Press the Loc/Rem key for five seconds, until Local? or Remote? is displayed.
2. Confirm with Enter.
3. Cancel with Esc.

Local mode

Local mode is used for temporary operation. When switched to LOCAL operation, the AC drive is controlled via the defined Local operation mode, i.e. [2171] and [2172]. The actual status of the AC drive will not change, e.g. Run/Stop conditions and the actual speed will remain exactly the same. When the AC drive is set to Local operation, the display will show **L** in area B in the display.

The AC drive will be started and stopped using the keys on the control panel. The reference signal can be controlled using the + and - keys on the keyboard, when in the menu [310] according to the selection in Keyboard Reference menu [369].

Remote mode

When the AC drive is switched to REMOTE operation, the AC drive will be controlled according to selected control methods in the menu's Reference Control [214], Run/Stop Control [215] and Reset Control [216]. The actual operation status of the AC drive will reflect the status and settings of the programmed control selections, e.g. Start/Stop status and settings of the programmed control selections, acceleration or deceleration speed according to the selected reference value in the menu Acceleration Time [331] / Deceleration Time [332].

To monitor the actual Local or Remote status of the AC drive control, a "Loc/Rem" function is available on the Digital Outputs or Relays. When the AC drive is set to Local, the signal on the DigOut or Relay will be active high, in Remote the signal will be inactive low. See menu Digital Outputs [540] and Relays [550].

9.2.6 Function keys

The function keys operate the menus and are also used for programming and read-outs of all the menu settings.

Table 21 Function keys







| | | |
|---|---------------|--|
|  | ENTER key: | <ul style="list-style-type: none"> - step to a lower menu level - confirm a changed setting |
|  | ESCAPE key: | <ul style="list-style-type: none"> - step to a higher menu level - ignore a changed setting, without confirming |
|  | PREVIOUS key: | <ul style="list-style-type: none"> - step to a previous menu within the same level - go to more significant digit in edit mode |
|  | NEXT key: | <ul style="list-style-type: none"> - step to a next menu within the same level - go to less significant digit in edit mode |
|  | - key: | <ul style="list-style-type: none"> - decrease a value - change a selection |
|  | + key: | <ul style="list-style-type: none"> - increase a value - change a selection |

Fig. 56 Menu structure

9.3 The menu structure

The menu structure consists of 4 levels:

| | |
|------------------------|--|
| Main Menu 1st level | The first character in the menu number. |
| 2nd level | The second character in the menu number. |
| 3rd level | The third character in the menu number. |
| 4th level | The fourth character in the menu number. |

This structure is consequently independent of the number of menus per level.

For instance, a menu can have one selectable menu (Set/View Reference Value [310]), or it can have 17 selectable menus (menu Speeds [340]).

NOTE: If there are more than 10 menus within one level, the numbering continues in alphabetic order.

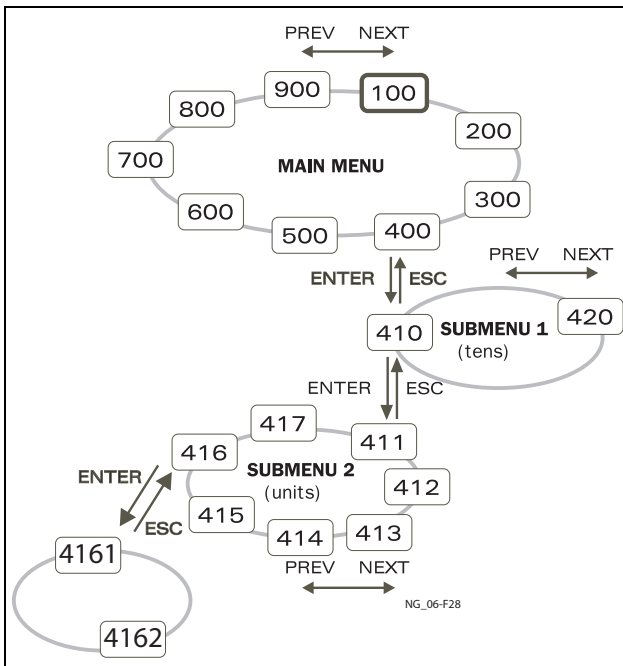

Fig. 57 Menu structure

9.3.1 The main menu

This section gives you a short description of the functions in the Main Menu.

100 Preferred View

Displayed at power-up. It displays the actual process value as default. Programmable for many other read-outs.

200 Main Setup

Main settings to get the AC drive operable. The motor data settings are the most important. Also option utility and settings.

300 Process and Application Parameters

Settings more relevant to the application such as Reference Speed, torque limitations, PID control settings, etc.

400 Shaft Power Monitor and Process Protection

The monitor function enables the AC drive to be used as a load monitor to protect machines and processes against mechanical overload and underload.

500 Inputs/Outputs and Virtual Connections

All settings for inputs and outputs are entered here.

600 Logical Functions and Timers

All settings for conditional signals are entered here.

700 View Operation and Status

Viewing all the operational data like frequency, load, power, current, etc.

800 View Trip Log

Viewing the last 10 trips in the trip memory.

900 Service Information and AC drive Data

Electronic type label for viewing the software version and AC drive type.

9.4 Programming during operation

Most of the parameters can be changed during operation without stopping the AC drive. Parameters that can not be changed are marked with a lock symbol in the display.

NOTE: If you try to change a function during operation that only can be changed when the motor is stopped, the message "Stop First" is displayed.

9.5 Editing values in a menu

Most values in the second row in a menu can be changed in two different ways. Enumerated values like the baud rate can only be changed with alternative 1.

| | |
|------|----------|
| 2621 | Baudrate |
| Stp | 38400 |

Alternative 1

When you press the + or - keys to change a value, the cursor is flashing to the left in the display and the value is increased or decreased when you press the appropriate key. If you keep the + or - keys pressed, the value will increase or decrease continuously. When you keep the key pressed the change speed will increase. The Toggle key is used to change the sign of the entered value. The sign of the value will also change when zero is passed. Press Enter to confirm the value.

| | |
|-----|----------|
| 331 | Acc Time |
| Stp | 2.00s |

▲ Flashing

Alternative 2

Press the + or - key to enter edit mode. Then press the Prev or Next key to move the cursor to the right most position of the value that should be changed. The cursor will make the selected character flashes. Move the cursor using the Prev or Next keys. When you press the + or - keys, the character at the cursor position will increase or decrease. This alternative is suitable when you want to make large changes, i.e. from 2 s to 400 s. To change the sign of the value, press the toggle key. This makes it possible to enter negative values.

Example: When you press Next the 4 will flash.

```

331      Acc Time
StpA      4.00s
    
```

Flashing ↑

Press Enter to save the setting and Esc to leave the edit mode.

9.6 Copy current parameter to all sets

When a parameter is displayed, press the Enter key for 5 seconds. Now the text To all sets? is displayed. Press Enter to copy the setting for current parameter to all sets.

9.7 Programming example

This example shows how to program a change of the Acc. Time set from 2.0 s to 4.0 s.

The flashing cursor indicates that a change has taken place but is not saved yet. If at this moment, the power fails, the change will not be saved.

Use the ESC, Prev, Next or the Toggle keys to proceed and to go to other menus.

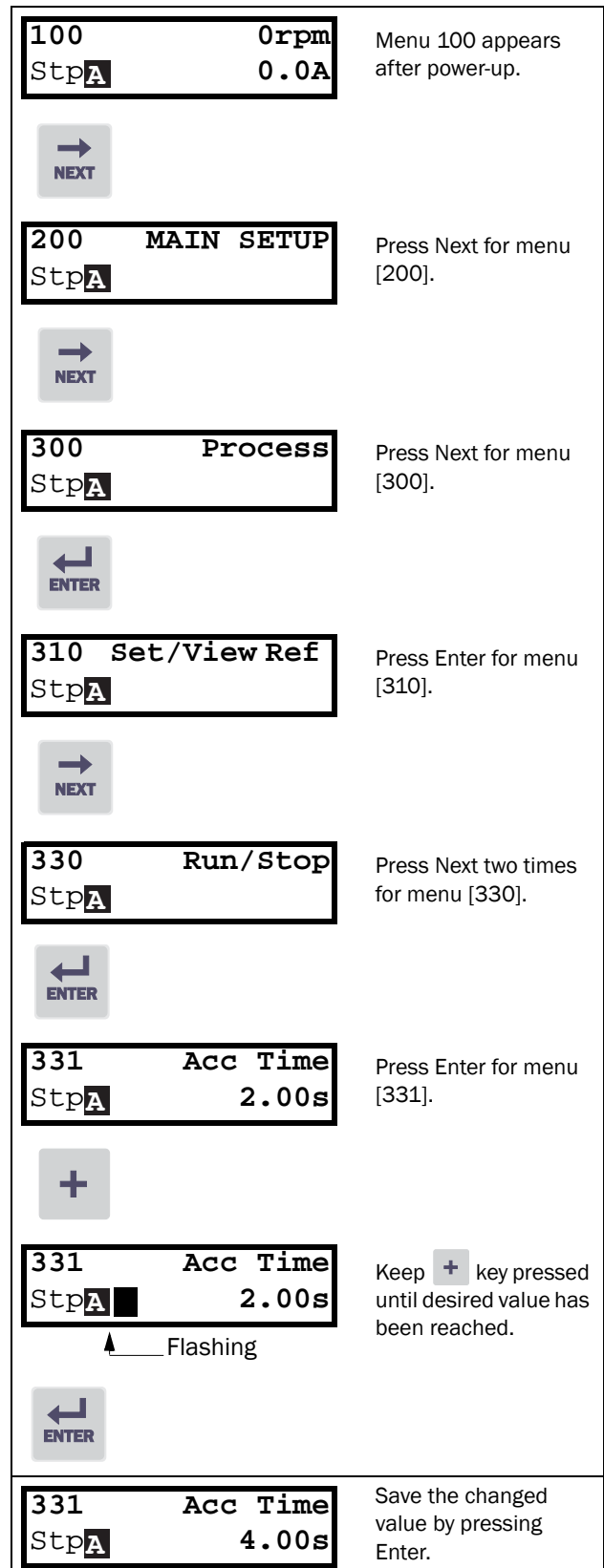

Fig. 58 Programming example

10. Serial communication

The AC drive provides possibility for different types of serial communication.

- Modbus RTU via RS232/485
- Fieldbuses as Profibus DP and DeviceNet
- Industrial Ethernet as Modbus/TCP

10.1 Modbus RTU

The AC drive has an asynchronous serial communication interface behind the control panel. It is also possible to use the isolated RS232/485 option board (if installed).

The protocol used for data exchange is based on the Modbus RTU protocol, originally developed by Modicon. The physical connection is RS232. The AC drive acts as a slave with address 1 in a master-slave configuration. The communication is half-duplex. It has a standard non return zero (NRZ) format.

The baud rate is fixed to 9600 (Control panel RS232 port).

The character frame format (always 11 bits) has:

- one start bit
- eight data bits
- two stop bits
- no parity

It is possible to temporarily connect a personal computer with for example the software EmoSoftCom (programming and monitoring software) to the RS232 connector on the control panel. This can be useful when copying parameters between AC drives etc. For permanent connection of a personal computer you have to use one of the communication option boards.

NOTE: This RS232 port is not isolated.



WARNING!

Correct and safe use of a RS232 connection depends on the ground pins of both ports being the same potential. Problems can

occur when connecting two ports of e.g. machinery and computers where both ground pins are not the same potential. This may cause hazardous ground loops that can destroy the RS232 ports.

The control panel RS232 connection is not galvanically isolated.

The RS232/485 option board is galvanically isolated.

Note that the control panel RS232 connection can safely be used in combination with commercial available isolated USB to RS232 converters.

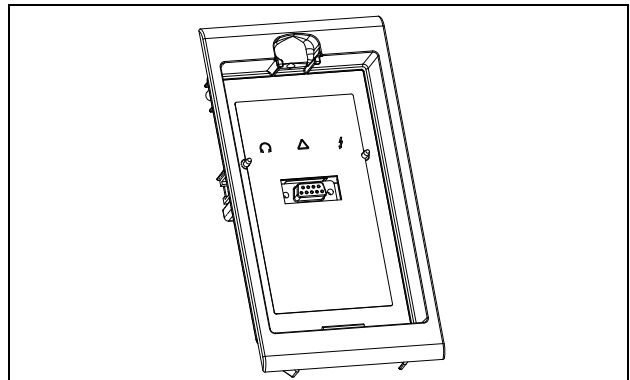

Fig. 59 RS232 connector behind the control panel

10.2 Parameter sets

Communication information for the different parameter sets.

The different parameter sets in the AC drive have the following DeviceNet instance numbers and Profibus slot/index numbers:

| Parameter set | Modbus/DeviceNet Instance number | Profibus Slot/Index |
|---------------|----------------------------------|---------------------|
| A | 43001-43556 | 168/160 to 170/205 |
| B | 44001-44529 | 172/140 to 174/185 |
| C | 45001-45529 | 176/120 to 178/165 |
| D | 46001-46529 | 180/100 to 182/145 |

Parameter set A contains parameters 43001 to 43556. The parameter sets B, C and D contains the same type of information. For example parameter 43123 in parameter set A contain the same type of information as 44123 in parameter set B.

A DeviceNet instance number can easily be converted into a Profibus slot/index number according to description in section section 11.8.2, page 165.

10.3 Motor data

Communication information for the different motors.

| Motor | Modbus/DeviceNet Instance number | Profibus Slot/Index |
|-------|----------------------------------|---------------------|
| M1 | 43041-43048 | 168/200 to 168/207 |
| M2 | 44041-44048 | 172/180 to 174/187 |
| M3 | 45041-45048 | 176/160 to 176/167 |
| M4 | 46041-46048 | 180/140 to 180/147 |

M1 contains parameters 43041 to 43048. The M2, M3, and M4 contains the same type of information. For example parameter 43043 in motor M1 contain the same type of information as 44043 in M2.

A DeviceNet instance number can easily be converted into a Profibus slot/index number according to description in section section 11.8.2, page 165.

10.4 Start and stop commands

Set start and stop commands via serial communication.

| Modbus/DeviceNet Instance number | Function |
|----------------------------------|---|
| 42901 | Reset |
| 42902 | Run, active together with either RunR or RunL to perform start. |
| 42903 | RunR |
| 42904 | RunL |

Note! Bipolar reference mode is activated if both RunR and RunL is active.

10.5 Reference signal

When menu Reference Control [214] is set to "Com" the following parameter data should be used:

| | |
|------------------|-------------------|
| Default | 0 |
| Range | -32768 to 32767 |
| Corresponding to | -100% to 100% ref |

Communication information

| | |
|-----------------------------------|--------|
| Modbus /DeviceNet Instance number | 42905 |
| Profibus slot /Index | 168/64 |
| Fieldbus format | Int |
| Modbus format | Int |

10.5.1 Process value

It is also possible to send the Process value feedback signal over a bus (e.g. from a process or temperature sensor) for use with PID Process controller [380].

Set menu Process Source [321] to F(Bus). Use following parameter data for the process value:

| | |
|------------------|-------------------|
| Default | 0 |
| Range | -32768 to 32767 |
| Corresponding to | -100% to 100% ref |

Communication information

| | |
|-----------------------------------|--------|
| Modbus /DeviceNet Instance number | 42906 |
| Profibus slot /Index | 168/65 |
| Fieldbus format | Int |
| Modbus format | Int |

Example:

(See the Fieldbus manual for detailed information)

We would like to control the AC drive over a bus system using the first two bytes of the Basic Control Message by setting menu [2661] FB Signal 1 to 49972. Further, we also want to transmit a 16 bit signed reference and a 16 bit process value. This is done by setting menu [2662] FB Signal 2 to 42905 and menu [2663] FB Signal 3 to 42906.

NOTE! It is possible to view the transmitted process value in control panel menu Operation [710]. The presented value is depending on settings in menus Process Min [324] and Process Max [325].

10.6 Description of the Elnt formats

A parameter with EInt format can be represented in two different formats (F). Either as a 15 bit unsigned integer format (F= 0) or a Floating point format (F=1). The most significant bit (B15) indicates the format used. See detailed description below.

All parameters written to a register may be rounded to the number of significant digits used in the internal system.

The matrix below describes the contents of the 16-bit word for the two different Elnt formats:

| B15 | B14 | B13 | B12 | B11 | B10 | B9 | B8 | B7 | B6 | B5 | B4 | B3 | B2 | B1 | B0 |
|-----|-----|-----|-----|-----|-----|----|----|----|----|----|----|----|----|----|----|
| F=1 | e3 | e2 | e1 | e0 | m10 | m9 | m8 | m7 | m6 | m5 | m4 | m3 | m2 | m1 | m0 |
| F=0 | B14 | B13 | B12 | B11 | B10 | B9 | B8 | B7 | B6 | B5 | B4 | B3 | B2 | B1 | B0 |

If the format bit (B15) is 0, then all bits may be treated as a standard unsigned integer (UInt)

If the format bit is 1, then is the number interpreted as this:

Value = M * 10^E, where M=m10..m0 represents a two- complement signed mantissa and E= e3..e0 represents a two- complement signed exponent.

NOTE: Parameters with EInt format may return values both as 15 bit unsigned int (F=0) or in Floating point (F=1).

Example, resolution

If you write the value 1004 to a register and this register has 3 significant digits, it will be stored as 1000.

In the Floating point format (F=1), one 16-bit word is used to represent large (or very small numbers) with 3 significant digits.

If data is read or written as a fixed point (i.e. no decimals) number between 0-32767, the 15 bit Unsigned integer format (F=0) may be used.

Detailed description of Floating point format

e3-e0 4-bit signed exponent. Gives a value range:

-8..+7 (binary 1000 .. 0111)

m10-m0 11-bit signed mantissa.Gives a value range:

-1024..+1023 (binary 10000000000..01111111111)

A signed number should be represented as a two complement binary number, like below:

Value Binary

-8 1000

-7 1001

..

-2 1110

-1 1111

0 0000

1 0001

2 0010

..

6 0110

7 0111

The value represented by the Floating point format is m·10^e.

To convert a value from the Floating point format to a floating point value, use the formula above.

To convert a floating point value to the Floating point format, see the C-code example below.

Example, Floating point format

The number 1.23 would be represented by this in Floating point format,

```
F EEEE MMMMMMMMMMMM
1 1110 00001111011
F=1 -> floating point format used
E=-2
M=123
```

The value is then 123x10⁻² = 1.23

Example 15bit unsigned int format

The value 72.0 can be represented as the fixed point number 72. It is within the range 0-32767, which means that the 15-bit fixed point format may be used.

The value will then be represented as:

| B15 | B14 | B13 | B12 | B11 | B10 | B9 | B8 | B7 | B6 | B5 | B4 | B3 | B2 | B1 | B0 |
|-----|-----|-----|-----|-----|-----|----|----|----|----|----|----|----|----|----|----|
| 0 | 0 | 0 | 0 | 0 | 0 | 0 | 0 | 0 | 1 | 0 | 0 | 1 | 0 | 0 | 0 |

Where bit 15 indicates that we are using the fixed point format (F=0).

Programming example:

```
typedef struct
{
    int m:11; // mantissa, -1024..1023
    int e: 4; // exponent -8..7
    unsigned int f: 1; // format, 1->special emoint format
}    eint16;
//-----
unsigned short int float_to_eint16(float value)
{
    eint16 etmp;
    int dec=0;

    while (floor(value) != value && dec<16)
    {
        dec++; value*=10;
    }
    if (value>=0 && value<=32767 && dec==0)
        *(short int *)&etmp=(short int)value;
    else if (value>=-1000 && value<0 && dec==0)
    {
        etmp.e=0;
        etmp.f=1;
        etmp.m=(short int)value;
    }
    else
    {
        etmp.m=0;
        etmp.f=1;
        etmp.e=-dec;
        if (value>=0)
            etmp.m=1; // Set sign
        else
            etmp.m=-1; // Set sign
        value=fabs(value);
        while (value>1000)
        {
            etmp.e++; // increase exponent
            value=value/10;
        }
        value+=0.5; // round
        etmp.m=etmp.m*value; // make signed
    }
    return (*(unsigned short int *)&etmp);
}
//-----
float eint16_to_float(unsigned short int value)
{
    float f;
    eint16 evalue;

    evalue=*(eint16 *)&value;
    if (evalue.f)
    {
        if (evalue.e>=0)
            f=(int)evalue.m*pow10(evalue.e);
        else
            f=(int)evalue.m/pow10(abs(evalue.e));
    }
    else
        f=value;

    return f;
}
//-----
```

11. Functional Description

This chapter describes the menus and parameters in the software. You will find a short description of each function and information about default values, ranges, etc. There are also tables containing communication information. You will find the Modbus, DeviceNet and Fieldbus address for each parameter as well as the enumeration for the data.

NOTE: Functions marked with the sign  cannot be changed during Run Mode.

Description of table layout

| Menu no. Menu name | | |
|-----------------------|----------------------------|-------------|
| Status Selected value | | |
| Default: | | |
| Selection or range | Integer value of selection | Description |

Resolution of settings

The resolution for all range settings described in this chapter is 3 significant digits. Exceptions are speed values which are presented with 4 significant digits. Table 22 shows the resolutions for 3 significant digits.

Table 22

| 3 Digit | Resolution |
|-------------|------------|
| 0.01-9.99 | 0.01 |
| 10.0-99.9 | 0.1 |
| 100-999 | 1 |
| 1000-9990 | 10 |
| 10000-99900 | 100 |

11.1 Preferred View [100]

This menu is displayed at every power-up. During operation, the menu [100] will automatically be displayed when the keyboard is not operated for 5 minutes. The automatic return function will be switched off when the Toggle and Stop key is pressed simultaneously. As default it displays the actual speed and torque.

| | |
|-------------|--------------|
| 100 | 0rpm |
| StpA | 0.0Nm |

Menu [100], Preferred View displays the settings made in menu [110], 1st line, and [120], 2nd line. See Fig. 60.

| | |
|-------------|------------|
| 100 | (1st Line) |
| StpA | (2nd Line) |

Fig. 60 Display functions

11.1.1 1st Line [110]

Sets the content of the upper row in the menu [100] Preferred View.”

| 110 1st Line | | |
|-------------------|----|----------------------|
| StpA Process Val | | |
| Default: | | Process Val |
| Dependent on menu | | |
| Process Val | 0 | Process value |
| Speed | 1 | Speed |
| Torque | 2 | Torque |
| Process Ref | 3 | Process reference |
| Shaft Power | 4 | Shaft power |
| EI Power | 5 | Electrical power |
| Current | 6 | Current |
| Output volt | 7 | Output voltage |
| Frequency | 8 | Frequency |
| DC Voltage | 9 | DC voltage |
| Heatsink Tmp | 10 | Heatsink temperature |
| Motor Temp * | 11 | Motor temperature |
| AC drive Status | 12 | AC drive status |
| Run Time | 13 | Run Time |
| Energy | 14 | Energy |
| Mains Time | 15 | Mains time |

* The “Motor temp” is only visible if you have the option PTC/PT100 card installed and a PT100 input is selected in menu[236].

Communication information

| | |
|----------------------------------|---------|
| Modbus Instance no/DeviceNet no: | 43001 |
| Profibus slot/index | 168/160 |
| Fieldbus format | UInt |
| Modbus format | UInt |

11.1.2 2nd Line [120]

Sets the content of the lower row in the menu [100] Preferred View. Same selection as in menu [110].

| | |
|---|--------|
| 120 2nd Line Stop A Torque | |
| Default: | Torque |

11.2 Main Setup [200]

The Main Setup menu contains the most important settings to get the AC drive operational and set up for the application. It includes different sub menus concerning the control of the unit, motor data and protection, utilities and automatic resetting of faults. This menu will instantaneously be adapted to build in options and show the required settings.

11.2.1 Operation [210]

Selections concerning the used motor, AC drive mode, control signals and serial communication are described in this submenu and is used to set the AC drive up for the application.

Language [211]

Select the language used on the LC Display. Once the language is set, this selection will not be affected by the Load Default command.

| | | |
|--|---------|------------------|
| 211 Language Stop A English | | |
| Default: | English | |
| English | 0 | English selected |
| Svenska | 1 | Swedish selected |
| Nederlands | 2 | Dutch selected |
| Deutsch | 3 | German selected |
| Français | 4 | French selected |
| Español | 5 | Spanish selected |
| Русский | 6 | Russian selected |
| Italiano | 7 | Italian selected |
| Česky | 8 | Czech selected |
| Turkish | 9 | Turkish selected |

Communication information

| | |
|----------------------------------|---------|
| Modbus Instance no/DeviceNet no: | 43011 |
| Profibus slot/index | 168/170 |
| Fieldbus format | UInt |
| Modbus format | UInt |

Select Motor [212]

This menu is used if you have more than one motor in your application. Select the motor to define. It is possible to define up to four different motors, M1 to M4, in the AC drive.

| 212 Select Motor | | StpA | M1 |
|------------------|----|--|----|
| Default: | M1 | | |
| M1 | 0 | Motor Data is connected to selected motor. | |
| M2 | 1 | | |
| M3 | 2 | | |
| M4 | 3 | | |

Communication information

| | |
|----------------------------------|---------|
| Modbus Instance no/DeviceNet no: | 43012 |
| Profibus slot/index | 168/171 |
| Fieldbus format | UInt |
| Modbus format | UInt |

Drive Mode [213]

This menu is used to set the control mode for the motor. Settings for the reference signals and read-outs is made in menu Process source, [321].

- Speed Mode offers an accurate control of the motor speed independently of the load. The Speed mode also increases the accuracy of the different analogue output signals that are related to the motor speed. Speed mode can also be used if several motors of same type and size are connected in parallel. Requires all motors to be mechanically connected to the load.
- Torque Mode can be selected for applications where the motor shaft torque needs to be controlled independently of the speed.
- V/Hz Mode (output speed [712] in rpm) is used when several motors in parallel of different type or size are connected or if parallel motors are not mechanically connected to the load.

| 213 Drive Mode | | StpA | Speed |
|----------------|-------|--|-------|
| Default: | Speed | | |
| Speed | 0 | The AC drive is speed controlled. Reference given= speed reference with ramp. Speed and torque limits can be set. Using "direct torque control" as motor control method. | |

| 213 Drive Mode | | StpA | Speed |
|----------------|---|--|-------|
| Torque | 1 | The AC drive is torque controlled. Reference given=torque reference without ramp. Speed and torque limit can be set. Using "direct torque control" as motor control method. NOTE: No ramps active in the AC drive. Care must be taken. | |
| V/Hz | 2 | All control loops are related to frequency control. NOTE: All the functions and menu read-outs with regard to speed and rpm (e.g. Max Speed = 1500 rpm, Min Speed=0 rpm, etc.) remain speed and rpm, although they represent the output frequency. | |

Communication information

| | |
|----------------------------------|---------|
| Modbus Instance no/DeviceNet no: | 43013 |
| Profibus slot/index | 168/172 |
| Fieldbus format | UInt |
| Modbus format | UInt |

Reference control [214]

To control the speed of the motor, the AC drive needs a reference signal. This reference signal can be controlled by a remote source from the installation, the keyboard of the AC drive, or by serial or fieldbus communication. Select the required reference control for the application in this menu.

| 214 Ref Control | | |
|------------------|--------|---|
| Stp ^A | | Remote |
| Default: | Remote | |
| Remote | 0 | The reference signal comes from the analogue inputs of the terminal strip (terminals 1-22). |
| Keyboard | 1 | Reference is set with the + and - keys on the Control Panel. Can only be done in menu Set/View reference [310]. |
| Com | 2 | The reference is set via the serial communication (RS 485, Fieldbus.) See section section 10.5 for further information. |
| Option | 3 | The reference is set via an option. Only available if the option can control the reference value. |

NOTE: If the reference is switched from Remote to Keyboard, the last remote reference value will be the default value for the control panel.

Communication information

| | |
|----------------------------------|---------|
| Modbus Instance no/DeviceNet no: | 43014 |
| Profibus slot/index | 168/173 |
| Fieldbus format | UInt |
| Modbus format | UInt |

Run/Stop Control [215]

This function is used to select the source for run and stop commands. Start/stop via analogue signals can be achieved by combining a few functions. This is described in the Chapter 7.2 page 37.

| 215 Run/Stp Ctrl | | |
|------------------|--------|---|
| Stp ^A | | Remote |
| Default: | Remote | |
| Remote | 0 | The start/stop signal comes from the digital inputs of the terminal strip (terminals 1-22). For settings, see menu group [330] and [520]. |
| Keyboard | 1 | Start and stop is set on the Control Panel. |
| Com | 2 | The start/stop is set via the serial communication (RS 485, Fieldbus.) See Fieldbus or RS232/485 option manual for details. |
| Option | 3 | The start/stop is set via an option. |

Communication information

| | |
|----------------------------------|---------|
| Modbus Instance no/DeviceNet no: | 43015 |
| Profibus slot/index | 168/174 |
| Fieldbus format | UInt |
| Modbus format | UInt |

Reset Control [216]

When the AC drive is stopped due to a failure, a reset command is required to make it possible to restart the AC drive. Use this function to select the source of the reset signal.

| <div style="border: 2px solid black; padding: 2px; display: inline-block;"> 216 Reset Ctrl Stp^A Remote </div> | | |
|---|---|---|
| Default: | | Remote |
| Remote | 0 | The command comes from the inputs of the terminal strip (terminals 1-22). |
| Keyboard | 1 | The command comes from the command keys of the Control Panel. |
| Com | 2 | The command comes from the serial communication (RS 485, Fieldbus). |
| Remote + Keyb | 3 | The command comes from the inputs of the terminal strip (terminals 1-22) or the keyboard. |
| Com + Keyb | 4 | The command comes from the serial communication (RS485, Fieldbus) or the keyboard. |
| Rem+Keyb +Com | 5 | The command comes from the inputs of the terminal strip (terminals 1-22), the keyboard or the serial communication (RS485, Fieldbus). |
| Option | 6 | The command comes from an option. Only available if the option can control the reset command. |

Communication information

| | |
|----------------------------------|---------|
| Modbus Instance no/DeviceNet no: | 43016 |
| Profibus slot/index | 168/175 |
| Fieldbus format | UInt |
| Modbus format | UInt |

Local/Remote key function [217]

The Toggle key on the keyboard, see section 9.2.5, page 54, has two functions and is activated in this menu. As default the key is just set to operate as a Toggle key that moves you easily through the menus in the toggle loop. The second function of the key allows you to easily swap between Local and normal operation (set up via [214] and [215]) of the AC drive. Local mode can also be activated via a digital input. If both [2171] and [2172] is set to Standard, the function is disabled.

| <div style="border: 2px solid black; padding: 2px; display: inline-block;"> 2171 LocRefCtrl Stp^A Standard </div> | | |
|--|---|---|
| Default: | | Standard |
| Standard | 0 | Local reference control set via [214] |
| Remote | 1 | Local reference control via remote |
| Keyboard | 2 | Local reference control via keyboard |
| Com | 3 | Local reference control via communication |

Communication information

| | |
|----------------------------------|---------|
| Modbus Instance no/DeviceNet no: | 43009 |
| Profibus slot/index | 168/168 |
| Fieldbus format | UInt |
| Modbus format | UInt |

| <div style="border: 2px solid black; padding: 2px; display: inline-block;"> 2172 LocRunCtrl Stp^A Standard </div> | | |
|--|---|--|
| Default: | | Standard |
| Standard | 0 | Local Run/Stop control set via [215] |
| Remote | 1 | Local Run/Stop control via remote |
| Keyboard | 2 | Local Run/Stop control via keyboard |
| Com | 3 | Local Run/Stop control via communication |

Communication information

| | |
|----------------------------------|---------|
| Modbus Instance no/DeviceNet no: | 43010 |
| Profibus slot/index | 168/169 |
| Fieldbus format | UInt |
| Modbus format | UInt |

Lock Code [218]

To prevent the keyboard being used or to change the setup of the AC drive and/or process control, the keyboard can be locked with a password. This menu, Lock Code [218], is used to lock and unlock the keyboard. Enter the password "291" to lock/unlock the keyboard operation. If the keyboard is not locked (default) the selection "Lock Code?" will appear. If the keyboard is already locked, the selection "Unlock Code?" will appear.

When the keyboard is locked, parameters can be viewed but not changed. The reference value can be changed and the AC drive can be started, stopped and reversed if these functions are set to be controlled from the keyboard.

| | |
|----------------------|--------|
| 218 Lock Code | |
| Stp A 0 | |
| Default: | 0 |
| Range: | 0-9999 |

Rotation [219]

Overall limitation of motor rotation direction

This function limits the overall rotation, either to left or right or both directions. This limit is prior to all other selections, e.g.: if the rotation is limited to right, a Run-Left command will be ignored. To define left and right rotation we assume that the motor is connected U-U, V-V and W-W.

Speed Direction and Rotation

The speed direction can be controlled by:

- RunR/RunL commands on the control panel.
- RunR/RunL commands on the terminal strip (terminals 1-22).
- Via the serial interface options.
- The parameter sets.

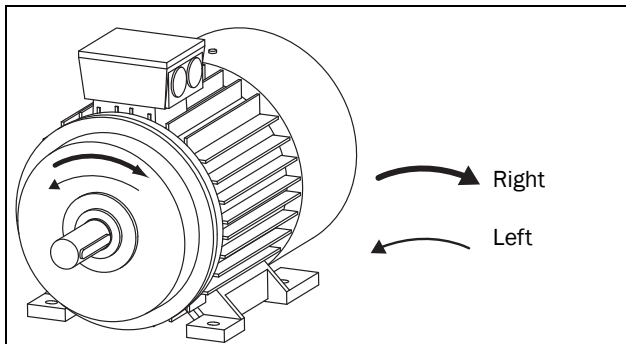

Fig. 61 Rotation

In this menu you set the general rotation for the motor.

| | | |
|---------------------|-------|--|
| 219 Rotation | | |
| Stp A R+L | | |
| Default: | R + L | |
| R | 1 | Speed direction is limited to right rotation. The input and key RunL are disabled. |
| L | 2 | Speed direction is limited to left rotation. The input and key RunR are disabled. |
| R+L | 3 | Both speed directions allowed. |

Communication information

| | |
|----------------------------------|---------|
| Modbus Instance no/DeviceNet no: | 43019 |
| Profibus slot/index | 168/178 |
| Fieldbus format | UInt |
| Modbus format | UInt |

11.2.2 Remote Signal Level/Edge [21A]

In this menu you select the way to control the inputs for RunR, RunL and Reset that are operated via the digital inputs on the terminal strip. The inputs are default set for level-control, and will be active as long as the input is made and kept high. When edge-control is selected, the input will be activated by the low to high transition of the input. See Chapter 7.2 page 37 for more information.

| | | |
|-----------------------|-------|--|
| 21A Level/Edge | | |
| Stp A Level | | |
| Default: | Level | |
| Level | 0 | The inputs are activated or deactivated by a continuous high or low signal. Is commonly used if, for example, a PLC is used to operate the AC drive. |
| Edge | 1 | The inputs are activated by a transition; for Run and Reset from "low" to "high" and for Stop from "high" to "low". |

Communication information

| | |
|----------------------------------|---------|
| Modbus Instance no/DeviceNet no: | 43020 |
| Profibus slot/index | 168/179 |
| Fieldbus format | UInt |
| Modbus format | UInt |



CAUTION!

Level controlled inputs DO NOT comply with the Machine Directive if the inputs are directly used to start and stop the machine.

NOTE: Edge controlled inputs can comply with the Machine Directive (see the Chapter 8. page 51) if the inputs are directly used to start and stop the machine.

11.2.3 Mains supply voltage [21B]



WARNING!
This menu must be set according to the AC drive product label and the supply voltage used. Wrong setting might damage the AC drive or brake resistor.

In this menu the nominal mains supply voltage connected to the AC drive can be selected. The setting will be valid for all parameter sets. The default setting, Not defined, is never selectable and is only visible until a new value is selected.

Once the supply voltage is set, this selection will not be affected by the Load Default command [243].

Brake chopper activation level is adjusted using the setting of [21B].

NOTE: The setting is affected by the Load from CP command [245] and if loading parameter file via EmoSoftCom.

| 21B Supply Volts | | |
|------------------------------|---|---|
| Stp ^A Not defined | | |
| Default: | | Not defined |
| Not Defined | 0 | Inverter default value used. Only valid if this parameter is never set. |
| 220-240 V | 1 | Only valid for JNVX48 |
| 380-415 V | 3 | Only valid for JNVX48/52 |
| 440-480 V | 4 | Only valid for JNVX48/52 |
| 500-525 V | 5 | Only valid for JNVX52/69 |
| 550-600 V | 6 | Only valid for JNVX69 |
| 660-690 V | 7 | Only valid for JNVX69 |

Communication information

| | |
|----------------------------------|--------|
| Modbus Instance no/DeviceNet no: | 43381 |
| Profibus slot/index | 170/30 |
| Fieldbus format | UInt |
| Modbus format | UInt |

11.2.4 Motor Data [220]

In this menu you enter the motor data to adapt the AC drive to the connected motor. This will increase the control accuracy as well as different read-outs and analogue output signals.

Motor M1 is selected as default and motor data entered will be valid for motor M1. If you have more than one motor you need to select the correct motor in menu [212] before entering motor data.

NOTE 1: The parameters for motor data cannot be changed during run mode.

NOTE 2: The default settings are for a standard 4-pole motor according to the nominal power of the AC drive.

NOTE 3: Parameter set cannot be changed during run if the sets is set for different motors.

NOTE 4: Motor Data in the different sets M1 to M4 can be revert to default setting in menu [243], Default>Set.



WARNING!
Enter the correct motor data to prevent dangerous situations and assure correct control.

Motor Voltage [221]

Set the nominal motor voltage.

| 221 Motor Volts | |
|---------------------------|---|
| Stp ^A M1: 400V | |
| Default: | 400 V for JNVX 48 500 V for JNVX 52 690 V for JNVX 69 |
| Range: | 100-700 V |
| Resolution | 1 V |

NOTE: The Motor Volts value will always be stored as a 3 digit value with a resolution of 1 V.

Communication information

| | |
|----------------------------------|------------------|
| Modbus Instance no/DeviceNet no: | 43041 |
| Profibus slot/index | 168/200 |
| Fieldbus format | Long, 1=0.1 V |
| Modbus format | EInt |

Motor Frequency [222]

Set the nominal motor frequency.

| | |
|--|-----------|
|  <div style="border: 2px solid black; padding: 2px; display: inline-block;"> 222 Motor Freq Stp A M1: 50Hz </div> | |
| Default: | 50 Hz |
| Range: | 24-300 Hz |
| Resolution | 1 Hz |

Communication information

| | |
|----------------------------------|--------------|
| Modbus Instance no/DeviceNet no: | 43042 |
| Profibus slot/index | 168/201 |
| Fieldbus format | Long, 1=1 Hz |
| Modbus format | EInt |

Motor Power [223]

Set the nominal motor power. If parallel motors, set the value as sum of motors power.

| | |
|--|----------------------|
|  <div style="border: 2px solid black; padding: 2px; display: inline-block;"> 223 Motor Power Stp A M1: (P_{NOM}) kW </div> | |
| Default: | $P_{NOM}VSD$ |
| Range: | 1W-120% x P_{NOM} |
| Resolution | 3 significant digits |

NOTE: The Motor Power value will always be stored as a 3 digit value in W up to 999 W and in kW for all higher powers.

Communication information

| | |
|----------------------------------|----------------|
| Modbus Instance no/DeviceNet no: | 43043 |
| Profibus slot/index | 168/202 |
| Fieldbus format | Long, 1=1 W |
| Modbus format | EInt |

P_{NOM} is the nominal AC drive power.

Motor Current [224]

Set the nominal motor current. If parallel motors, set the value as sum of motors current.

| | |
|---|--------------------------------|
|  <div style="border: 2px solid black; padding: 2px; display: inline-block;"> 224 Motor Curr Stp A M1: (I_{MOT}) A </div> | |
| Default: | I_{MOT} (see Note 2 page 61) |
| Range: | 25 - 150% x I_{NOM} |

Communication information

| | |
|----------------------------------|------------------|
| Modbus Instance no/DeviceNet no: | 43044 |
| Profibus slot/index | 168/203 |
| Fieldbus format | Long, 1=0.1 A |
| Modbus format | EInt |

NOTE: The default settings are for a standard 4-pole motor according to the nominal power of the AC drive.



WARNING!

Do not connect motors with less than 25% of the nominal power of the AC drive. This may disrupt the control of the motor.

Motor Speed [225]

Set the nominal asynchronous motor speed.

| | |
|---|--------------------------------|
|  <div style="border: 2px solid black; padding: 2px; display: inline-block;"> 225 Motor Speed Stp A M1: (n_{MOT}) rpm </div> | |
| Default: | n_{MOT} (see Note 2 page 61) |
| Range: | 50 - 18000 rpm |
| Resolution | 1 rpm, 4 sign digits |



WARNING!

Do NOT enter a synchronous (no-load) motor speed.

NOTE: Maximum speed [343] is not automatically changed when the motor speed is changed.

NOTE: Entering a wrong, too low value can cause a dangerous situation for the driven application due to high speeds.

Communication information

| | |
|----------------------------------|-----------------|
| Modbus Instance no/DeviceNet no: | 43045 |
| Profibus slot/index | 168/204 |
| Fieldbus format | UInt 1=1 rpm |

| | |
|---------------|------|
| Modbus format | UInt |
|---------------|------|

Motor Poles [226]

When the nominal speed of the motor is ≤ 500 rpm, the additional menu for entering the number of poles, [226], appears automatically. In this menu the actual pole number can be set which will increase the control accuracy of the AC drive.

| | |
|--|-------|
|  226 Motor Poles StpA M1: 4 | |
| Default: | 4 |
| Range: | 2-144 |

Communication information

| | |
|----------------------------------|----------------|
| Modbus Instance no/DeviceNet no: | 43046 |
| Profibus slot/index | 168/205 |
| Fieldbus format | Long, 1=1 pole |
| Modbus format | EInt |

Motor Cos φ [227]

Set the nominal Motor cosphi (power factor).

| | |
|---|---|
|  227 Motor Cosφ StpA M1: Cos φ _{NOM} | |
| Default: | Cos φ _{NOM} (see Note 2 page 61) |
| Range: | 0.50 - 1.00 |

Communication information

| | |
|----------------------------------|--------------|
| Modbus Instance no/DeviceNet no: | 43047 |
| Profibus slot/index | 168/206 |
| Fieldbus format | Long, 1=0.01 |
| Modbus format | EInt |

Motor ventilation [228]

Parameter for setting the type of motor ventilation. Affects the characteristics of the I^2t motor protection by lowering the actual overload current at lower speeds.

| | |
|--|---|
|  228 Motor Vent StpA M1: Self | |
| Default: | Self |
| None | 0 Limited I^2t overload curve. |
| Self | 1 Normal I^2t overload curve. Means that the motor stands lower current at low speed. |
| Forced | 2 Expanded I^2t overload curve. Means that the motor stands almost the whole current also at lower speed. |

Communication information

| | |
|----------------------------------|---------|
| Modbus Instance no/DeviceNet no: | 43048 |
| Profibus slot/index | 168/207 |
| Fieldbus format | UInt |
| Modbus format | UInt |

When the motor has no cooling fan, None is selected and the current level is limited to 55% of rated motor current.

With a motor with a shaft mounted fan, Self is selected and the current for overload is limited to 87% from 20% of synchronous speed. At lower speed, the overload current allowed will be smaller.

When the motor has an external cooling fan, Forced is selected and the overload current allowed starts at 90% from rated motor current at zero speed, up to nominal motor current at 70% of synchronous speed.

Fig. 62 shows the characteristics with respect for Nominal Current and Speed in relation to the motor ventilation type selected.

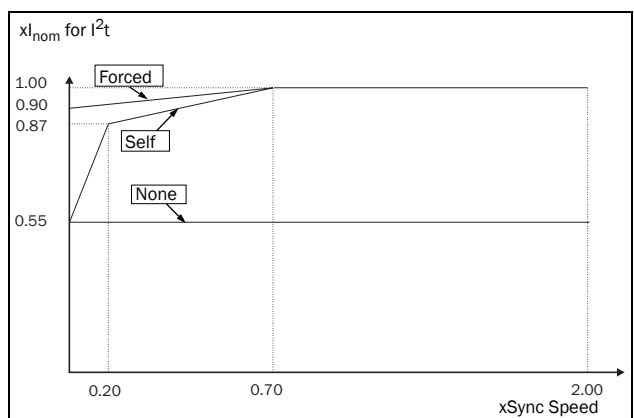

Fig. 62 I^2t curves

Motor Identification Run [229]

This function is used when the AC drive is put into operation for the first time. To achieve an optimal control performance, fine tuning of the motor parameters using a motor ID run is needed. During the test run the display shows “Test Run” flashing.

To activate the Motor ID run, select either “Short” or “Extended” and press Enter. Then press RunL or RunR on the control panel to start the ID run. If menu [219] Rotation is set to L the RunR key is inactive and vice versa. The ID run can be aborted by giving a Stop command via the control panel or Enable input. The parameter will automatically return to OFF when the test is completed. The message “Test Run OK!” is displayed. Before the AC drive can be operated normally again, press the STOP/RESET key on the control panel.

During the Short ID run the motor shaft does not rotate. The AC drive measures the rotor and stator resistance.

During the Extended ID run the motor is powered on and rotates. The AC drive measures the rotor and stator resistance as well as the induction and the inertia for the motor.

| | |
|--|---|
|  229 Motor ID-Run Stp _A M1: Off | |
| Default: | Off, see Note |
| Off | 0 Not active |
| Short | 1 Parameters are measured with injected DC current. No rotation of the shaft will occur. |
| Extended | 2 Additional measurements, not possible to perform with DC current, are done directly after a short ID run. The shaft will rotate and must be disconnected from the load. |

Communication information

| | |
|----------------------------------|---------|
| Modbus Instance no/DeviceNet no: | 43049 |
| Profibus slot/index | 168/208 |
| Fieldbus format | UInt |
| Modbus format | UInt |



WARNING!
During the extended ID RUN, the motor will rotate. Take safety measures to avoid unforeseen dangerous situations.

NOTE: To run the AC drive it is not mandatory for the ID RUN to be executed, but without it the performance will not be optimal.

NOTE: If the ID Run is aborted or not completed the message “Interrupted!” will be displayed. The previous data do not need to be changed in this case. Check that the motor data are correct.

Encoder Feedback [22B]

Only visible if the Encoder option board is installed. This parameter enables or disables the encoder feedback from the motor to the AC drive.

| | |
|---|-----------------------------|
|  22B Encoder Stp _A M1: Off | |
| Default: | Off |
| Off | 0 Encoder feedback disabled |
| On | 1 Encoder feedback enabled |

Communication information

| | |
|----------------------------------|---------|
| Modbus Instance no/DeviceNet no: | 43051 |
| Profibus slot/index | 168/210 |
| Fieldbus format | UInt |
| Modbus format | UInt |

Encoder Pulses [22C]

Only visible if the Encoder option board is installed. This parameter describes the number of pulses per rotation for your encoder, i.e. it is encoder specific. For more information please see the encoder manual.

| | |
|--|---------|
|  22C Enc Pulses Stp _A M1: 1024 | |
| Default: | 1024 |
| Range: | 5-16384 |

Communication information

| | |
|----------------------------------|-----------------|
| Modbus Instance no/DeviceNet no: | 43052 |
| Profibus slot/index | 168/211 |
| Fieldbus format | Long, 1=1 pulse |
| Modbus format | EInt |

Encoder Speed [22D]

Only visible if the Encoder option board is installed. This parameter shows the measured motor speed. To check if the encoder is correctly installed, set Encoder Feedback [22B] to Off, run the AC drive at any speed and compare with the value in this menu. The value in this menu [22D] should be about the same as the motor speed [712]. If you get the wrong sign for the value, swap encoder input A and B.

| | |
|--|--------------------------------|
|  22D Enc Speed Stp _A M1: XXrpm | |
| Unit: | rpm |
| Resolution: | speed measured via the encoder |

Communication information

| | |
|----------------------------------|--------|
| Modbus Instance no/DeviceNet no: | 42911 |
| Profibus slot/index | 168/70 |
| Fieldbus format | Int |
| Modbus format | Int |

NOTE: Switching frequency is fixed when "Sine Filt" is selected. This means that it is not possible to control the switching frequency based on temperature.

Encoder Pulse counter [22F]

Only visible if the Encoder option is installed. Added menu/parameter for accumulated QEP (Quadrature Encoder Pulse) encoder pulses. Can be preset to any value within bus format used (Int = 2 byte, Long = 4 byte).

| | |
|-----------------------------------|---|
| 22F Enc Puls Ctr StpA 0 | |
| Default: | 0 |
| Resolutione | 1 |

Communication information

| | |
|----------------------------------|------------------------------|
| Modbus Instance no/DeviceNet no: | 42912 |
| Profibus slot/index | 168/71 |
| Fieldbus format | Long, 1=1 quad encoder pulse |
| Modbus format | Int |

Note! For a 1024 pulse encoder [22F] will count 1024 * 4= 4096 pulses per turn.

11.2.5 Motor Protection [230]

This function protects the motor against overload based on the standard IEC 60947-4-2.

Motor I²t Type [231]

The motor protection function makes it possible to protect the motor from overload as published in the standard IEC 60947-4-2. It does this using Motor I²t Current, [232] as a reference. The Motor I²t Time [233] is used to define the time behaviour of the function. The current set in [232] can be delivered infinite in time. If for instance in [233] a time of 1000 s is chosen the upper curve of Fig. 63 is valid. The value on the x-axis is the multiple of the current chosen in [232]. The time [233] is the time that an overloaded motor is switched off or is reduced in power at 1.2 times the current set in [232].

| | | |
|---|------|---|
| 231 Mot I²t Type StpA M1: Trip | | |
| Default: | Trip | |
| Off | 0 | I ² t motor protection is not active. |
| Trip | 1 | When the I ² t time is exceeded, the AC drive will trip on "Motor I ² t". |
| Limit | 2 | This mode helps to keep the inverter running when the Motor I ² t function is just before tripping the AC drive. The trip is replaced by current limiting with a maximum current level set by the value out of the menu [232]. In this way, if the reduced current can drive the load, the AC drive continues running. |

Communication information

| | |
|----------------------------------|---------|
| Modbus Instance no/DeviceNet no: | 43061 |
| Profibus slot/index | 168/220 |
| Fieldbus format | UInt |
| Modbus format | UInt |

NOTE: When Mot I²t Type=Limit, the AC drive can control the speed < MinSpeed to reduce the motor current.

Motor I²t Current [232]

Sets the current limit for the motor I²t protection.

| | |
|------------------------------------|----------------------------|
| 232 Mot I²t Curr | |
| Stp _A 100% | |
| Default: | 100% of I _{MOT} |
| Range: | 0-150% of I _{MOT} |

Communication information

| | |
|----------------------------------|------------|
| Modbus Instance no/DeviceNet no: | 43062 |
| Profibus slot/index | 168/221 |
| Fieldbus format | Long, 1=1% |
| Modbus format | Elnt |

NOTE: When the selection Limit is set in menu [231], the value must be above the no-load current of the motor.

Motor I²t Time [233]

Sets the time of the I²t function. After this time the limit for the I²t is reached if operating with 120% of the I²t current value. Valid when start from 0 rpm.

NOTE: Not the time constant of the motor.

| | |
|------------------------------------|-----------|
| 233 Mot I²t Time | |
| Stp _A M1: 60s | |
| Default: | 60 s |
| Range: | 60-1200 s |

Communication information

| | |
|----------------------------------|-------------|
| Modbus Instance no/DeviceNet no: | 43063 |
| Profibus slot/index | 168/222 |
| Fieldbus format | Long, 1=1 s |
| Modbus format | Elnt |

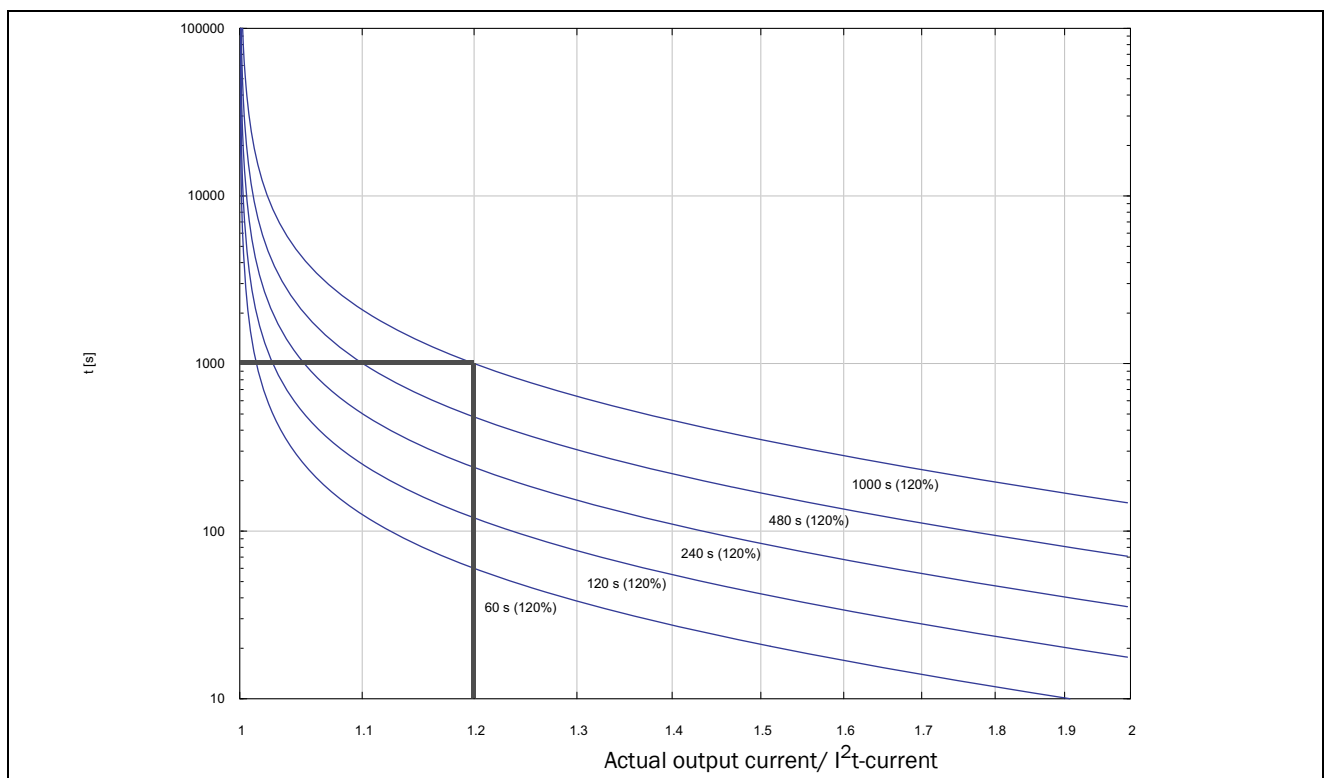

Fig. 63 I²t function

Fig. 63 shows how the function integrates the square of the motor current according to the Mot I²t Curr [232] and the Mot I²t Time [233].

When the selection Trip is set in menu [231] the AC drive trips if this limit is exceeded.

When the selection Limit is set in menu [231] the AC drive reduces the torque if the integrated value is 95%

or closer to the limit, so that the limit cannot be exceeded.

NOTE: If it is not possible to reduce the current, the AC drive will trip after exceeding 110% of the limit.

Example

In Fig. 63 the thick grey line shows the following example.

- Menu [232] Mot I²t Curr is set to 100%.
1.2 x 100% = 120%
- Menu [233] Mot I²t Time is set to 1000 s.

This means that the AC drive will trip or reduce after 1000 s if the current is 1.2 times of 100% nominal motor current.

Thermal Protection [234]

Only visible if the PTC/PT100 option board is installed. Set the PTC input for thermal protection of the motor. The motor thermistors (PTC) must comply with DIN 44081/44082. Please refer to the manual for the PTC/PT100 option board.

Menu [234] PTC contains functions to enable or disable the PTC input. Here you can select and activate PTC and/or PT100.

| 234 Thermal Prot | | |
|------------------|---|--|
| Stp A Off | | |
| Default: | | Off |
| Off | 0 | PTC and PT100 motor protection are disabled. |
| PTC | 1 | Enables the PTC protection of the motor via the insulated option board. |
| PT100 | 2 | Enables the PT100 protection for the motor via the insulated option board. |
| PTC+PT100 | 3 | Enables the PTC protection as well as the PT100 protection for the motor via the insulated option board. |

Communication information

| | |
|----------------------------------|---------|
| Modbus Instance no/DeviceNet no: | 43064 |
| Profibus slot/index | 168/223 |
| Fieldbus format | UInt |
| Modbus format | UInt |

NOTE: PTC option and PT100 selections can only be selected in menu [234] if the option board is mounted.

NOTE: If you select the PTC option, the PT100 inputs are ignored.

Motor Class [235]

Only visible if the PTC/PT100 option board is installed. Set the class of motor used. The trip levels for the

PT100 sensor will automatically be set according to the setting in this menu.

| 235 Mot Class | | |
|----------------------|---|---------|
| Stp A F 140°C | | |
| Default: | | F 140°C |
| A 100°C | 0 | |
| E 115°C | 1 | |
| B 120°C | 2 | |
| F 140°C | 3 | |
| F Nema 145°C | 4 | |
| H 165°C | 5 | |

Communication information

| | |
|----------------------------------|---------|
| Modbus Instance no/DeviceNet no: | 43065 |
| Profibus slot/index | 168/224 |
| Fieldbus format | UInt |
| Modbus format | UInt |

NOTE: This menu is only valid for PT 100.

PT100 Inputs [236]

Sets which of PT100 inputs that should be used for thermal protection. Deselecting not used PT100 inputs on the PTC/PT100 option board in order to ignore those inputs, i.e. extra external wiring is not needed if port is not used.

| 236 PT100 Inputs | | |
|------------------|---|---|
| StpA PT100 1+2+3 | | |
| Default: | PT100 1+2+3 | |
| Selection: | PT100 1, PT100 2, PT100 1+2, PT100 3, PT100 1+3, PT100 2+3, PT100 1+2+3 | |
| PT100 1 | 1 | Channel 1 used for PT100 protection |
| PT100 2 | 2 | Channel 2 used for PT100 protection |
| PT100 1+2 | 3 | Channel 1+2 used for PT100 protection |
| PT100 3 | 4 | Channel 3 used for PT100 protection |
| PT100 1+3 | 5 | Channel 1+3 used for PT100 protection |
| PT100 2+3 | 6 | Channel 2+3 used for PT100 protection |
| PT100 1+2+3 | 7 | Channel 1+2+3 used for PT100 protection |

Communication information

| | |
|----------------------------------|---------|
| Modbus Instance no/DeviceNet no: | 43066 |
| Profibus slot/index | 168/225 |
| Fieldbus format | UInt |
| Modbus format | UInt |

NOTE: This menu is only valid for PT 100 thermal protection if PT100 is enabled in menu [234].

Motor PTC [237]

In this menu the internal motor PTC hardware option is enabled. This PTC input complies with DIN 44081/44082. Please refer to the manual for the PTC/PT100 option board for electrical specification.

This menu is only visible if a PTC (or resistor <2 kOhm) is connected to terminals X1: 78–79.

To enable the function:

1. Connect the thermistor wires to X1: 78–79 or for testing the input, connect a resistor to the terminals. Use resistor value between 50 and 2000 ohm.

Menu [237] will now appear.

2. Enable input by setting menu [237] Motor PTC=On.

If enabled and <50 ohm a sensor error trip will occur. The message “Motor PTC” is shown.

If the function is disabled and the PTC or resistor is removed, the menu will disappear after the next power up

NOTE: This option is available only for (size B to D) JNVX48/52-0003-0074.

| 237 Motor PTC | | |
|---------------|-----|----------------------------------|
| StpA Off | | |
| Default: | Off | |
| Off | 0 | Motor PTC protection is disabled |
| On | 1 | Motor PTC protection is enabled |

Communication information

| | |
|----------------------------------|---------|
| Modbus Instance no/DeviceNet no: | 43067 |
| Profibus slot/index | 168/226 |
| Fieldbus format | UInt |
| Modbus format | UInt |

11.2.6 Parameter Set Handling [240]

There are four different parameter sets available in the AC drive. These parameter sets can be used to set the AC drive up for different processes or applications such as different motors used and connected, activated PID controller, different ramp time settings, etc.

A parameter set consists of all parameters with the exception of the Global parameters. The Global parameters are only able to have one value for all parameter sets.

Following parameters are Global: [211] Language, [217] Local Remote, [218] Lock Code, [220] Motor Data, [241] Select Set, [260] Serial Communication and [21B]Mains Supply Voltage.

NOTE: Actual timers are common for all sets. When a set is changed the timer functionality will change according to the new set, but the timer value will stay unchanged.

Select Set [241]

Here you select the parameter set. Every menu included in the parameter sets is designated A, B, C or D depending on the active parameter set. Parameter sets can be selected from the keyboard, via the programmable digital inputs or via serial communication. Parameter sets can be changed during the run. If the sets are using different motors (M1 to M4) the set will be changed when the motor is stopped.

| 241 Select Set | | |
|-----------------------|---|--|
| Stp A A | | |
| Default: | | A |
| Selection: | | A, B, C, D, DigIn, Com, Option |
| A | 0 | Fixed selection of one of the 4 parameter sets A, B, C or D. |
| B | 1 | |
| C | 2 | |
| D | 3 | |
| DigIn | 4 | Parameter set is selected via a digital input. Define which digital input in menu [520], Digital inputs. |
| Com | 5 | Parameter set is selected via serial communication. |
| Option | 6 | The parameter set is set via an option. Only available if the option can control the selection. |

Communication information

| | |
|----------------------------------|---------|
| Modbus Instance no/DeviceNet no: | 43022 |
| Profibus slot/index | 168/181 |
| Fieldbus format | UInt |
| Modbus format | UInt |

The active set can be viewed with function [721] FI status.

NOTE: Parameter set cannot be changed during run if this also would imply a change of the motor set (M2-M4).

Copy Set [242]

This function copies the content of a parameter set into another parameter set.

| 242 Copy Set | | |
|----------------------------|----|---------------------|
| Stp A A>B | | |
| Default: | | A>B |
| A>B | 0 | Copy set A to set B |
| A>C | 1 | Copy set A to set C |
| A>D | 2 | Copy set A to set D |
| B>A | 3 | Copy set B to set A |
| B>C | 4 | Copy set B to set C |
| B>D | 5 | Copy set B to set D |
| C>A | 6 | Copy set C to set A |
| C>B | 7 | Copy set C to set B |
| C>D | 8 | Copy set C to set D |
| D>A | 9 | Copy set D to set A |
| D>B | 10 | Copy set D to set B |
| D>C | 11 | Copy set D to set C |

Communication information

| | |
|----------------------------------|---------|
| Modbus Instance no/DeviceNet no: | 43021 |
| Profibus slot/index | 168/180 |
| Fieldbus format | UInt |
| Modbus format | UInt |

NOTE: The actual value of menu [310] will not be copied into the other set.

A>B means that the content of parameter set A is copied into parameter set B.

Load Default Values Into Set [243]

With this function three different levels (factory settings) can be selected for the four parameter sets. When loading the default settings, all changes made in the software are set to factory settings. This function also includes selections for loading default settings to the four different Motor Data Sets.

| 243 Default>Set | | StpA | A |
|-----------------|----|---|---|
| Default: | A | | |
| A | 0 | Only the selected parameter set will revert to its default settings. | |
| B | 1 | | |
| C | 2 | | |
| D | 3 | | |
| ABCD | 4 | All four parameter sets will revert to the default settings. | |
| Factory | 5 | All settings, except [211], [221]-[22D], [261], [3A1] and [923], will revert to the default settings. | |
| M1 | 6 | Only the selected motor set will revert to its default settings. | |
| M2 | 7 | | |
| M3 | 8 | | |
| M4 | 9 | | |
| M1234 | 10 | All four motor sets will revert to default settings. | |

Communication information

| | |
|----------------------------------|---------|
| Modbus Instance no/DeviceNet no: | 43023 |
| Profibus slot/index | 168/182 |
| Fieldbus format | UInt |
| Modbus format | UInt |

NOTE: Trip log hour counter and other VIEW ONLY menus are not regarded as settings and will be unaffected.

NOTE: If "Factory" is selected, the message "Sure?" is displayed. Press the + key to display "Yes" and then Enter to confirm.

NOTE: The parameters in menu [220], Motor data, are not affected by loading defaults when restoring parameter sets A-D.

Copy All Settings to Control Panel [244]

All the settings can be copied into the control panel including the motor data. Start commands will be ignored during copying.

| 244 Copy to CP | | |
|----------------|---------|------------------------|
| StpA | | No Copy |
| Default: | No Copy | |
| No Copy | 0 | Nothing will be copied |
| Copy | 1 | Copy all settings |

Communication information

| | |
|----------------------------------|---------|
| Modbus Instance no/DeviceNet no: | 43024 |
| Profibus slot/index | 168/183 |
| Fieldbus format | UInt |
| Modbus format | UInt |

NOTE: The actual value of menu [310] will not be copied into control panel memory set.

Load Settings from Control Panel [245]

This function can load all four parameter sets from the control panel to the AC drive. Parameter sets from the source AC drive are copied to all parameter sets in the target AC drive, i.e. A to A, B to B, C to C and D to D.

Start commands will be ignored during loading.

| | | 245 Load from CP StpA No Copy |
|--------------|----|--|
| Default: | | No Copy |
| No Copy | 0 | Nothing will be loaded. |
| A | 1 | Data from parameter set A is loaded. |
| B | 2 | Data from parameter set B is loaded. |
| C | 3 | Data from parameter set C is loaded. |
| D | 4 | Data from parameter set D is loaded. |
| ABCD | 5 | Data from parameter sets A, B, C and D are loaded. |
| A+Mot | 6 | Parameter set A and Motor data are loaded. |
| B+Mot | 7 | Parameter set B and Motor data are loaded. |
| C+Mot | 8 | Parameter set C and Motor data are loaded. |
| D+Mot | 9 | Parameter set D and Motor data are loaded. |
| ABCD+Mot | 10 | Parameter sets A, B, C, D and Motor data are loaded. |
| M1 | 11 | Data from motor 1 is loaded. |
| M2 | 12 | Data from motor 2 is loaded. |
| M3 | 13 | Data from motor 3 is loaded. |
| M4 | 14 | Data from motor 4 is loaded. |
| M1M2M3 M4 | 15 | Data from motor 1, 2, 3 and 4 are loaded. |
| All | 16 | All data is loaded from the control panel. |

Communication information

| | |
|----------------------------------|---------|
| Modbus Instance no/DeviceNet no: | 43025 |
| Profibus slot/index | 168/184 |
| Fieldbus format | UInt |
| Modbus format | UInt |

NOTE: Loading from the control panel will not affect the value in menu [310].

11.2.7 Trip Autoreset/Trip Conditions [250]

The benefit of this feature is that occasional trips that do not affect the process will be automatically reset. Only when the failure keeps on coming back, recurring at defined times and therefore cannot be solved by the AC drive, will the unit give an alarm to inform the operator that attention is required.

For all trip functions that can be activated by the user you can select to control the motor down to zero speed according to set deceleration ramp to avoid water hammer.

Also see section 12.2, page 170.

Autoreset example:

In an application it is known that the main supply voltage sometimes disappears for a very short time, a so-called “dip”. That will cause the AC drive to trip an “Undervoltage alarm”. Using the Autoreset function, this trip will be acknowledged automatically.

- Enable the Autoreset function by making the reset input continuously high.
- Activate the Autoreset function in the menu [251], Number of trips.
- Select in menus [252] to [25N] the Trip condition that are allowed to be automatically reset by the Autoreset function after the set delay time has expired.

Number of Trips [251]

Any number set above 0 activates the Autoreset. This means that after a trip, the AC drive will restart automatically according to the number of attempts selected. No restart attempts will take place unless all conditions are normal.

If the Autoreset counter (not visible) contains more trips than the selected number of attempts, the Autoreset cycle will be interrupted. No Autoreset will then take place.

If there are no trips for more than 10 minutes, the Autoreset counter decreases by one.

If the maximum number of trips has been reached, the trip message hour counter is marked with an “A”.

If the Autoreset is full then the AC drive must be reset by a normal Reset.

Example:

- Autoreset = 5
- Within 10 minutes 6 trips occur
- At the 6th trip there is no Autoreset, because the Autoreset trip log contains 5 trips already.
- To reset, apply a normal reset: set the reset input high to low and high again to maintain the Autoreset function. The counter is reset.

| | |
|--|------------------|
| 251 No of Trips Stp A 0 | |
| Default: | 0 (no Autoreset) |
| Range: | 0-10 attempts |

Communication information

| | |
|----------------------------------|---------|
| Modbus Instance no/DeviceNet no: | 43071 |
| Profibus slot/index | 168/230 |
| Fieldbus format | UInt |
| Modbus format | UInt |

NOTE: An auto reset is delayed by the remaining ramp time.

Over temperature [252]

Delay time starts counting when the fault is gone. When the time delay has elapsed, the alarm will be reset if the function is active.

| | | |
|---|--------|----------|
| 252 Overtemp Stp A Off | | |
| Default: | Off | |
| Off | 0 | Off |
| 1-3600 | 1-3600 | 1-3600 s |

Communication information

| | |
|----------------------------------|-------------|
| Modbus Instance no/DeviceNet no: | 43072 |
| Profibus slot/index | 168/231 |
| Fieldbus format | Long, 1=1 s |
| Modbus format | Elnt |

NOTE: An auto reset is delayed by the remaining ramp time.

Overvolt D [253]

Delay time starts counting when the fault is gone. When the time delay has elapsed, the alarm will be reset if the function is active.

| | | |
|---|--------|----------|
| 253 Overvolt D Stp A Off | | |
| Default: | Off | |
| Off | 0 | Off |
| 1-3600 | 1-3600 | 1-3600 s |

Communication information

| | |
|----------------------------------|-------------|
| Modbus Instance no/DeviceNet no: | 43075 |
| Profibus slot/index | 168/234 |
| Fieldbus format | Long, 1=1 s |
| Modbus format | Elnt |

NOTE: An auto reset is delayed by the remaining ramp time.

Overvolt G [254]

Delay time starts counting when the fault is gone. When the time delay has elapsed, the alarm will be reset if the function is active.

| | | |
|---|--------|----------|
| 254 Overvolt G Stp A Off | | |
| Default: | Off | |
| Off | 0 | Off |
| 1-3600 | 1-3600 | 1-3600 s |

Communication information

| | |
|----------------------------------|-------------|
| Modbus Instance no/DeviceNet no: | 43076 |
| Profibus slot/index | 168/235 |
| Fieldbus format | Long, 1=1 s |
| Modbus format | Elnt |

Overvolt [255]

Delay time starts counting when the fault is gone. When the time delay has elapsed, the alarm will be reset if the function is active.

| | | |
|--|--------|----------|
| 255 Overvolt Stp A Off | | |
| Default: | Off | |
| Off | 0 | Off |
| 1-3600 | 1-3600 | 1-3600 s |

Communication information

| | |
|----------------------------------|-------------|
| Modbus Instance no/DeviceNet no: | 43077 |
| Profibus slot/index | 168/236 |
| Fieldbus format | Long, 1=1 s |
| Modbus format | EInt |

Motor Lost [256]

Delay time starts counting when the fault is gone. When the time delay has elapsed, the alarm will be reset if the function is active.

| | | |
|--|--------|----------|
| 256 Motor Lost Stp A Off | | |
| Default: | Off | |
| Off | 0 | Off |
| 1-3600 | 1-3600 | 1-3600 s |

NOTE: Only visible when Motor Lost is selected in menu [423].

Communication information

| | |
|----------------------------------|-------------|
| Modbus Instance no/DeviceNet no: | 43083 |
| Profibus slot/index | 168/242 |
| Fieldbus format | Long, 1=1 s |
| Modbus format | EInt |

Locked Rotor [257]

Delay time starts counting when the fault is gone. When the time delay has elapsed, the alarm will be reset if the function is active.

| | | |
|--|--------|----------|
| 257 Locked Rotor Stp A Off | | |
| Default: | Off | |
| Off | 0 | Off |
| 1-3600 | 1-3600 | 1-3600 s |

Communication information

| | |
|----------------------------------|-------------|
| Modbus Instance no/DeviceNet no: | 43086 |
| Profibus slot/index | 168/245 |
| Fieldbus format | Long, 1=1 s |
| Modbus format | EInt |

Power Fault [258]

Delay time starts counting when the fault is gone. When the time delay has elapsed, the alarm will be reset if the function is active.

| | | |
|---|--------|----------|
| 258 Power Fault Stp A Off | | |
| Default: | Off | |
| Off | 0 | Off |
| 1-3600 | 1-3600 | 1-3600 s |

Communication information

| | |
|----------------------------------|-------------|
| Modbus Instance no/DeviceNet no: | 43087 |
| Profibus slot/index | 168/246 |
| Fieldbus format | Long, 1=1 s |
| Modbus format | EInt |

Undervoltage [259]

Delay time starts counting when the fault is gone. When the time delay has elapsed, the alarm will be reset if the function is active.

| | | |
|--|--------|----------|
| 259 Undervoltage Stp A Off | | |
| Default: | Off | |
| Off | 0 | Off |
| 1-3600 | 1-3600 | 1-3600 s |

Communication information

| | |
|----------------------------------|-------------|
| Modbus Instance no/DeviceNet no: | 43088 |
| Profibus slot/index | 168/247 |
| Fieldbus format | Long, 1=1 s |
| Modbus format | EInt |

Motor I²t [25A]

Delay time starts counting when the fault is gone. When the time delay has elapsed, the alarm will be reset if the function is active.

| | | |
|--|--------|----------|
| 25A Motor I²t Stp A Off | | |
| Default: | Off | |
| Off | 0 | Off |
| 1-3600 | 1-3600 | 1-3600 s |

Communication information

| | |
|----------------------------------|-------------|
| Modbus Instance no/DeviceNet no: | 43073 |
| Profibus slot/index | 168/232 |
| Fieldbus format | Long, 1=1 s |
| Modbus format | EInt |

Motor I²t Trip Type [25B]

Select the preferred way to react to a Motor I²t trip.

| | | |
|--|------|---------------------------|
| 25B Motor I²t TT Stp A Trip | | |
| Default: | Trip | |
| Trip | 0 | The motor will trip |
| Deceleration | 1 | The motor will decelerate |

Communication information

| | |
|----------------------------------|---------|
| Modbus Instance no/DeviceNet no: | 43074 |
| Profibus slot/index | 168/233 |
| Fieldbus format | UInt |
| Modbus format | UInt |

PT100 [25C]

Delay time starts counting when the fault is gone. When the time delay has elapsed, the alarm will be reset if the function is active.

| | | |
|---|--------|----------|
| 25C PT100 Stp A Off | | |
| Default: | Off | |
| Off | 0 | Off |
| 1-3600 | 1-3600 | 1-3600 s |

Communication information

| | |
|----------------------------------|-------------|
| Modbus Instance no/DeviceNet no: | 43078 |
| Profibus slot/index | 168/237 |
| Fieldbus format | Long, 1=1 s |
| Modbus format | EInt |

PT100 Trip Type [25D]

Delay time starts counting when the fault is gone. When the time delay has elapsed, the alarm will be reset if the function is active.

| | |
|---|--------------------|
| 25D PT100 TT Stp A Trip | |
| Default: | Trip |
| Selection: | Same as menu [25B] |

Communication information

| | |
|----------------------------------|---------|
| Modbus Instance no/DeviceNet no: | 43079 |
| Profibus slot/index | 168/238 |
| Fieldbus format | UInt |
| Modbus format | UInt |

PTC [25E]

Delay time starts counting when the fault is gone. When the time delay has elapsed, the alarm will be reset if the function is active.

| | | |
|---|--------|----------|
| 25E PTC Stp A Off | | |
| Default: | Off | |
| Off | 0 | Off |
| 1-3600 | 1-3600 | 1-3600 s |

Communication information

| | |
|----------------------------------|-------------|
| Modbus Instance no/DeviceNet no: | 43084 |
| Profibus slot/index | 168/243 |
| Fieldbus format | Long, 1=1 s |
| Modbus format | EInt |

PTC Trip Type [25F]

Select the preferred way to react to a PTC trip.

| | |
|--|--------------------|
| 25F PTC TT Stp A Trip | |
| Default: | Trip |
| Selection: | Same as menu [25B] |

Communication information

| | |
|----------------------------------|---------|
| Modbus Instance no/DeviceNet no: | 43085 |
| Profibus slot/index | 168/244 |
| Fieldbus format | UInt |
| Modbus format | UInt |

External Trip Type [25H]

Select the preferred way to react to an alarm trip.

| | |
|---|--------------------|
| 25H Ext Trip TT Stp A Trip | |
| Default: | Trip |
| Selection: | Same as menu [25B] |

Communication information

| | |
|----------------------------------|---------|
| Modbus Instance no/DeviceNet no: | 43081 |
| Profibus slot/index | 168/240 |
| Fieldbus format | UInt |
| Modbus format | UInt |

External Trip [25G]

Delay time starts counting when the fault is gone. When the time delay has elapsed, the alarm will be reset if the function is active.

| | | |
|---|--------|----------|
| 25G Ext Trip Stp A Off | | |
| Default: | Off | |
| Off | 0 | Off |
| 1-3600 | 1-3600 | 1-3600 s |

Communication information

| | |
|----------------------------------|-------------|
| Modbus Instance no/DeviceNet no: | 43080 |
| Profibus slot/index | 168/239 |
| Fieldbus format | Long, 1=1 s |
| Modbus format | EInt |

Communication Error [25I]

Delay time starts counting when the fault is gone. When the time delay has elapsed, the alarm will be reset if the function is active.

| | | |
|--|--------|----------|
| 25I Com Error Stp A Off | | |
| Default: | Off | |
| Off | 0 | Off |
| 1-3600 | 1-3600 | 1-3600 s |

Communication information

| | |
|----------------------------------|-------------|
| Modbus Instance no/DeviceNet no: | 43089 |
| Profibus slot/index | 168/248 |
| Fieldbus format | Long, 1=1 s |
| Modbus format | EInt |

Communication Error Trip Type [25J]

Select the preferred way to react to a communication trip.

| | |
|--|--------------------|
| 25J Com Error TT Stp A Trip | |
| Default: | Trip |
| Selection: | Same as menu [25B] |

Communication information

| | |
|----------------------------------|---------|
| Modbus Instance no/DeviceNet no: | 43090 |
| Profibus slot/index | 168/249 |
| Fieldbus format | UInt |
| Modbus format | UInt |

Min Alarm [25K]

Delay time starts counting when the fault is gone. When the time delay has elapsed, the alarm will be reset if the function is active.

| | | |
|--|--------|----------|
| 25K Min Alarm Stp A Off | | |
| Default: | Off | |
| Off | 0 | Off |
| 1-3600 | 1-3600 | 1-3600 s |

Communication information

| | |
|----------------------------------|-------------|
| Modbus Instance no/DeviceNet no: | 43091 |
| Profibus slot/index | 168/250 |
| Fieldbus format | Long, 1=1 s |
| Modbus format | EInt |

Min Alarm Trip Type [25L]

Select the preferred way to react to a min alarm trip.

| | |
|--|--------------------|
| 25L Min Alarm TT Stp A Trip | |
| Default: | Trip |
| Selection: | Same as menu [25B] |

Communication information

| | |
|----------------------------------|---------|
| Modbus Instance no/DeviceNet no: | 43092 |
| Profibus slot/index | 168/251 |
| Fieldbus format | UInt |
| Modbus format | UInt |

Max Alarm [25M]

Delay time starts counting when the fault is gone. When the time delay has elapsed, the alarm will be reset if the function is active.

| | | |
|--|--------|----------|
| 25M Max Alarm Stp A Off | | |
| Default: | Off | |
| Off | 0 | Off |
| 1-3600 | 1-3600 | 1-3600 s |

Communication information

| | |
|----------------------------------|-------------|
| Modbus Instance no/DeviceNet no: | 43093 |
| Profibus slot/index | 168/252 |
| Fieldbus format | Long, 1=1 s |
| Modbus format | EInt |

Max Alarm Trip Type [25N]

Select the preferred way to react to a max alarm trip.

| | |
|--|--------------------|
| 25N Max Alarm TT Stp A Trip | |
| Default: | Trip |
| Selection: | Same as menu [25B] |

Communication information

| | |
|----------------------------------|---------|
| Modbus Instance no/DeviceNet no: | 43094 |
| Profibus slot/index | 168/253 |
| Fieldbus format | UInt |
| Modbus format | UInt |

Over current F [25O]

Delay time starts counting when the fault is gone. When the time delay has elapsed, the alarm will be reset if the function is active.

| | | |
|--|--------|----------|
| 25O Over curr F Stp A Off | | |
| Default: | Off | |
| Off | 0 | Off |
| 1-3600 | 1-3600 | 1-3600 s |

Communication information

| | |
|----------------------------------|-------------|
| Modbus Instance no/DeviceNet no: | 43082 |
| Profibus slot/index | 168/241 |
| Fieldbus format | Long, 1=1 s |
| Modbus format | Elnt |

Over Speed [25Q]

Delay time starts counting when the fault is gone. When the time delay has elapsed, the alarm will be reset if the function is active.

| | | |
|--|--------|----------|
| 25Q Over speed Stp A Off | | |
| Default: | Off | |
| Off | 0 | Off |
| 1-3600 | 1-3600 | 1-3600 s |

Communication information

| | |
|----------------------------------|-------------|
| Modbus Instance no/DeviceNet no: | 43096 |
| Profibus slot/index | 169/0 |
| Fieldbus format | Long, 1=1 s |
| Modbus format | Elnt |

External Motor Temperature [25R]

Delay time starts counting when the fault disappears. When the time delay has elapsed, the alarm will be reset if the function is active.

| | | |
|--|--------|----------|
| 25R Ext Mot Temp Stp A Off | | |
| Default: | Off | |
| Off | 0 | Off |
| 1-3600 | 1-3600 | 1-3600 s |

Communication information

| | |
|----------------------------------|-------------|
| Modbus Instance no/DeviceNet no: | 43097 |
| Profibus slot/index | 168/239 |
| Fieldbus format | Long, 1=1 s |
| Modbus format | Elnt |

External Motor Trip Type [25S]

Select the preferred way to react to an alarm trip.

| | |
|---|--------------------|
| 25S Ext Mot TT Stp A Trip | |
| Default: | Trip |
| Selection: | Same as menu [25B] |

Communication information

| | |
|----------------------------------|---------|
| Modbus Instance no/DeviceNet no: | 43098 |
| Profibus slot/index | 168/240 |
| Fieldbus format | UInt |
| Modbus format | UInt |

Liquid cooling low level [25T]

Delay time starts counting when the fault disappears. When the time delay has elapsed, the alarm will be reset if the function is active.

| | | |
|--|--------|----------|
| 25T LC Level Stp A Off | | |
| Default: | Off | |
| Off | 0 | Off |
| 1-3600 | 1-3600 | 1-3600 s |

Communication information

| | |
|----------------------------------|-------------|
| Modbus Instance no/DeviceNet no: | 43099 |
| Profibus slot/index | 169/3 |
| Fieldbus format | Long, 1=1 s |
| Modbus format | EInt |

Liquid Cooling Low level Trip Type [25U]

Select the preferred way to react to an alarm trip.

| | |
|---|--------------------|
| 25U LC Level TT Stp A Trip | |
| Default: | Trip |
| Selection: | Same as menu [25B] |

Communication information

| | |
|----------------------------------|-------|
| Modbus Instance no/DeviceNet no: | 43100 |
| Profibus slot/index | 169/4 |
| Fieldbus format | UInt |
| Modbus format | UInt |

Brake Fault [25V]

Select the preferred way to react to an alarm trip, activate auto reset and specify delay time.

| | |
|--|---|
| 25V Brk Fault Stp A Off | |
| Default | Off |
| Off | 0 Autoreset not activated. |
| 1 - 3600s | 1 - 3600s Brake fault auto reset delay time. |

Communication information

| | |
|----------------------------------|------------|
| Modbus Instance no/DeviceNet no: | 43070 |
| Profibus slot/index | 168/229 |
| Fieldbus format | Long, 1=1s |
| Modbus format | EInt |

11.2.8 Serial Communication [260]

This function is to define the communication parameters for serial communication. There are two types of options available for serial communication, RS232/485 (Modbus/RTU) and fieldbus modules (Profibus, DeviceNet and Ethernet).

For more information see chapter Serial communication and respective option manual.

Comm Type [261]

Select RS232/485 [262] or Fieldbus [263].

| | |
|---|--|
| 261 Com Type Stp A RS232/485 | |
| Default: | RS232/485 |
| RS232/485 | 0 RS232/485 selected |
| Fieldbus | 1 Fieldbus selected (Profibus, DeviceNet or Modbus/TCP) |

NOTE: Toggling the setting in this menu will perform a soft reset (re-boot) of the Fieldbus module.

RS232/485 [262]

Press Enter to set up the parameters for RS232/485 (Modbus/RTU) communication.

| |
|-----------------------------|
| 262 RS232/485 Stp |
|-----------------------------|

Baud rate [2621]

Set the baud rate for the communication.

NOTE: This baud rate is only used for the isolated RS232/485 option.

| | |
|---|-------------------------|
| 2621 Baudrate Stp A 9600 | |
| Default: | 9600 |
| 2400 | 0 |
| 4800 | 1 |
| 9600 | 2 Selected baud rate |
| 19200 | 3 |
| 38400 | 4 |

Address [2622]

Enter the unit address for the AC drive.

NOTE: This address is only used for the isolated RS232/485 option.

| | |
|---|-------|
| 2622 Address | |
| Stp A 1 | |
| Default: | 1 |
| Selection: | 1-247 |

Fieldbus [263]

Press Enter to set up the parameters for fieldbus communication.

| | |
|---------------------|--|
| 263 Fieldbus | |
| Stp A | |

Address [2631]

Enter the unit address of the AC drive.

| | |
|--|--------------------------------|
| 2631 Address | |
| Stp A 62 | |
| Default: | 62 |
| Range: | Profibus 0-126, DeviceNet 0-63 |
| Node address valid for Profibus and DeviceNet | |

Process Data Mode [2632]

Enter the mode of process data (cyclic data). For further information, see the Fieldbus option manual.

| | | |
|---|---|---|
| 2632 PrData Mode | | |
| Stp A Basic | | |
| Default: | | Basic |
| None | 0 | Control/status information is not used. |
| Basic | 4 | 4 byte process data control/status information is used. |
| Extended | 8 | 4 byte process data (same as Basic setting) + additional proprietary protocol for advanced users is used. |

Read/Write [2633]

Select read/write to control the inverter over a fieldbus network. For further information, see the Fieldbus option manual.

| | | |
|---|---|----|
| 2633 Read/Write | | |
| Stp A RW | | |
| Default: | | RW |
| RW | 0 | |
| Read | 1 | |
| Valid for process data. Select R (read only) for logging process without writing process data. Select RW in normal cases to control inverter. | | |

Additional Process Values [2634]

Define the number of additional process values sent in cyclic messages.

| | |
|---|-----|
| 2634 AddPrValues | |
| Stp A 0 | |
| Default: | 0 |
| Range: | 0-8 |

Communication Fault [264]

Main menu for communication fault/warning settings. For further details please see the Fieldbus option manual.

Communication Fault Mode [2641]

Selects action if a communication fault is detected.

| 2641 ComFlt Mode StpA Off | | |
|------------------------------|-----|--|
| Default: | Off | |
| Off | 0 | No communication supervision. |
| Trip | 1 | RS232/485 selected: The AC drive will trip if there is no communication for time set in parameter [2642]. Fieldbus selected: The AC drive will trip if: 1. The internal communication between the control board and fieldbus option is lost for time set in parameter [2642]. 2. If a serious network error has occurred. |
| Warning | 2 | RS232/485 selected: The AC drive will give a warning if there is no communication for time set in parameter [2642]. Fieldbus selected: The AC drive will give a warning if: 1. The internal communication between the control board and fieldbus option is lost for time set in parameter [2642]. 2. If a serious network error has occurred. |

NOTE: Menu [214] and/or [215] must be set to COM to activate the communication fault function.

Communication information

| | |
|----------------------------------|---------|
| Modbus Instance no/DeviceNet no: | 43037 |
| Profibus slot/index | 168/196 |
| Fieldbus format | UInt |
| Modbus format | UInt |

Communication Fault Time [2642]

Defines the delay time for the trip/warning.

| 2642 ComFlt Time StpA 0.5s | |
|-------------------------------|----------|
| Default: | 0.5 s |
| Range: | 0.1-15 s |

Communication information

| | |
|----------------------------------|---------------|
| Modbus Instance no/DeviceNet no: | 43038 |
| Profibus slot/index | 168/197 |
| Fieldbus format | Long, 1=0.1 s |
| Modbus format | Elnt |

Ethernet [265]

Settings for Ethernet module (Modbus/TCP). For further information, see the Fieldbus option manual.

NOTE: The Ethernet module must be re-booted to activate the below settings. For example by toggling parameter [261]. Non-initialized settings indicated by flashing display text.

IP Address [2651]

| 2651 IP Address 0. 0. 0. 0 | |
|-------------------------------|---------|
| Default: | 0.0.0.0 |

MAC Address [2652]

| 2652 MAC Address StpA 000000000000 | |
|---------------------------------------|---|
| Default: | An unique number for the Ethernet module. |

Subnet Mask [2653]

| 2653 Subnet Mask 0. 0. 0. 0 | |
|--------------------------------|---------|
| Default: | 0.0.0.0 |

Gateway [2654]

| | |
|-----------------------------------|---------|
| 2654 Gateway 0. 0. 0. 0 | |
| Default: | 0.0.0.0 |

DHCP [2655]

| | |
|--------------------------------------|--------|
| 2655 DHCP Stp A Off | |
| Default: | Off |
| Selection: | On/Off |

Fieldbus Signals [266]

Defines modbus mapping for additional process values. For further information, see the Fieldbus option manual.

FB Signal 1 - 16 [2661]-[266G]

Used to create a block of parameters which are read/written via communication. 1 to 8 read + 1 to 8 write parameters possible.

| | |
|---|---------|
| 2661 FB Signal 1 Stp A 0 | |
| Default: | 0 |
| Range: | 0-65535 |

Communication information

| | |
|----------------------------------|-----------------|
| Modbus Instance no/DeviceNet no: | 42801-42816 |
| Profibus slot/index | 167/215-167/230 |
| Fieldbus format | UInt |
| Modbus format | UInt |

FB Status [269]

Sub menus showing status of fieldbus parameters. Please see the Fieldbus manual for detailed information.

| | |
|-----------------------------|--|
| 269 FB Status Stp | |
|-----------------------------|--|

11.3 Process and Application Parameters [300]

These parameters are mainly adjusted to obtain optimum process or machine performance.

The read-out, references and actual values depends on selected process source, [321]:

Table 23

| Selected process source | Unit for reference and actual value | Resolution |
|-------------------------|-------------------------------------|------------|
| Speed | rpm | 4 digits |
| Torque | % | 3 digits |
| PT100 | °C | 3 digits |
| Frequency | Hz | 3 digits |

11.3.1 Set/View Reference Value [310]

View reference value

As default the menu [310] is in view operation. The value of the active reference signal is displayed. The value is displayed according to selected process source, [321] or the process unit selected in menu [322].

Set reference value

If the function Reference Control [214] is set to "Keyboard", the reference value can be set in menu Set/View Reference [310] or as a motor potentiometer with the + and - keys (default) on the control panel. Selection is made with parameter Keyboard Reference Mode in menu [369]. The ramp times used when setting the reference value with MotPot function selected in [369] are according to menus Acc MotPot [333] and Dec MotPot [334].

The ramp times used for the reference value when Normal function is selected in menu [369], are according to Acc Time [331] and Dec Time [332].

Menu [310] displays on-line the actual reference value according to the Mode Settings in Table 23.

| | |
|--|---|
| 310 Set/View ref Stp 0rpm | |
| Default: | 0 rpm |
| Dependent on: | Process Source [321] and Process Unit [322] |
| Speed mode | 0 - max speed [343] |
| Torque mode | 0 - max torque [351] |
| Other modes | Min according to menu [324] - max according to menu [325] |

| | |
|----------------------------------|---------|
| Modbus Instance no/DeviceNet no: | 42991 |
| Profibus slot/index | 168/150 |
| Fieldbus format | Long |
| Modbus format | EInt |

NOTE: The actual value in menu [310] is not copied, or loaded from the control panel memory when Copy Set [242], Copy to CP [244] or Load from CP [245] is performed.

NOTE: If the MotPot function is used, the reference value ramp times are according to the Acc MotPot [333] and Dec MotPot [334] settings. Actual speed ramp will be limited according to Acc Time [331] and Dec Time [332].

NOTE: Write access to this parameter is only allowed when menu "Ref Control [214] is set to Keyboard. When Reference control is used, see section "10.5 Reference signal" on page 60

11.3.2 Process Settings [320]

With these functions, the AC drive can be set up to fit the application. The menus [110], [120], [310], [362]-[368] and [711] use the process unit selected in [321] and [322] for the application, e.g. rpm, bar or m³/h. This makes it possible to easily set up the AC drive for the required process requirements, as well as for copying the range of a feedback sensor to set up the Process Value Minimum and Maximum in order to establish accurate actual process information.

Process Source [321]

Select the signal source for the process value that controls the motor. The Process Source can be set to act as a function of the process signal on AnIn F(AnIn), a function of the motor speed F(Speed), a function of the shaft torque F(Torque) or as a function of a process value from serial communication F(Bus). The right function to select depends on the characteristics and behaviour of the process. If the selection Speed, Torque or Frequency is set, the AC drive will use speed, torque or frequency as reference value.

Example

An axial fan is speed-controlled and there is no feedback signal available. The process needs to be controlled within fixed process values in "m³/hr" and a process read-out of the air flow is needed. The characteristic of this fan is that the air flow is linearly related to the actual speed. So by selecting F(Speed) as the Process Source, the process can easily be controlled.

The selection F(xx) indicates that a process unit and scaling is needed, set in menus [322]-[328]. This makes it possible to e.g. use pressure sensors to measure flow etc. If F(AnIn) is selected, the source is automatically connected to the AnIn which has Process Value as selected.

| 321 Proc Source | | |
|---------------------------|---|--|
| Stp A Speed | | |
| Default: | | Speed |
| F(AnIn) | 0 | Function of analogue input. E.g. via PID control, [330]. |
| Speed | 1 | Speed as process reference ¹ . |
| Torque | 2 | Torque as process reference ² . |
| PT100 | 3 | Temperature as process reference. |
| F(Speed) | 4 | Function of speed |
| F(Torque) | 5 | Function of torque ² |
| F(Bus) | 6 | Function of communication reference |
| Frequency | 7 | Frequency as process reference ¹ . |

¹. Only when Drive mode [213] is set to Speed or V/Hz.
². Only when Drive mode [213] is set to Torque.

NOTE: When PT100 is selected, use PT100 channel 1 on the PTC/PT100 option board.

NOTE: If Speed, Torque or Frequency is chosen in menu [321] Proc Source, menus [322] - [328] are hidden.

NOTE: The motor control method depends on the selection of drive mode [213], regardless of selected process source, [321].

NOTE: If F (Bus) is chosen in menu [321]see section 10.5.1 Process value.

NOTE: In case of conflicting setup between this Process Source, [321], selection and drive mode [213] the software will automatically overrule the selection in menu [321] according to the following:

[213]=Torque and [321]=Speed; internally [321]=Torque will be used.

[213]=Speed or V/Hz and [321]=Torque; internally [321]=Speed will be used.

Communication information

| | |
|----------------------------------|---------|
| Modbus Instance no/DeviceNet no: | 43302 |
| Profibus slot/index | 169/206 |
| Fieldbus format | UInt |
| Modbus format | UInt |

Process Unit [322]

| | | |
|----------------------|----|------------------------|
| 322 Proc Unit | | |
| Stp A rpm | | |
| Default: | | rpm |
| Off | 0 | No unit selection |
| % | 1 | Percent |
| °C | 2 | Degrees Centigrade |
| °F | 3 | Degrees Fahrenheit |
| bar | 4 | bar |
| Pa | 5 | Pascal |
| Nm | 6 | Torque |
| Hz | 7 | Frequency |
| rpm | 8 | Revolutions per minute |
| m ³ /h | 9 | Cubic meters per hour |
| gal/h | 10 | Gallons per hour |
| ft ³ /h | 11 | Cubic feet per hour |
| User | 12 | User defined unit |

Communication information

| | |
|----------------------------------|---------|
| Modbus Instance no/DeviceNet no: | 43303 |
| Profibus slot/index | 169/207 |
| Fieldbus format | UInt |
| Modbus format | UInt |

User-defined Unit [323]

This menu is only displayed if User is selected in menu [322]. The function enables the user to define a unit with six symbols. Use the Prev and Next key to move the cursor to required position. Then use the + and - keys to scroll down the character list. Confirm the character by moving the cursor to the next position by pressing the Next key.

| Character | No. for serial comm. | Character | No. for serial comm. |
|-----------|----------------------|-----------|----------------------|
| Space | 0 | m | 58 |
| 0-9 | 1-10 | n | 59 |
| A | 11 | ñ | 60 |
| B | 12 | o | 61 |
| C | 13 | ó | 62 |
| D | 14 | ô | 63 |
| E | 15 | p | 64 |
| F | 16 | q | 65 |
| G | 17 | r | 66 |
| H | 18 | s | 67 |
| I | 19 | t | 68 |
| J | 20 | u | 69 |
| K | 21 | ü | 70 |
| L | 22 | v | 71 |
| M | 23 | w | 72 |
| N | 24 | x | 73 |
| O | 25 | y | 74 |
| P | 26 | z | 75 |
| Q | 27 | å | 76 |
| R | 28 | ä | 77 |
| S | 29 | ö | 78 |
| T | 30 | ! | 79 |
| U | 31 | '' | 80 |
| Ü | 32 | # | 81 |
| V | 33 | \$ | 82 |
| W | 34 | % | 83 |
| X | 35 | & | 84 |
| Y | 36 | . | 85 |
| Z | 37 | (| 86 |
| Å | 38 |) | 87 |
| Ä | 39 | * | 88 |
| Ö | 40 | + | 89 |
| a | 41 | , | 90 |
| á | 42 | - | 91 |
| b | 43 | . | 92 |
| c | 44 | / | 93 |
| d | 45 | : | 94 |
| e | 46 | ; | 95 |
| é | 47 | < | 96 |

| Character | No. for serial comm. | Character | No. for serial comm. |
|-----------|----------------------|-----------|----------------------|
| ê | 48 | = | 97 |
| ë | 49 | > | 98 |
| f | 50 | ? | 99 |
| g | 51 | @ | 100 |
| h | 52 | ^ | 101 |
| i | 53 | _ | 102 |
| í | 54 | ° | 103 |
| j | 55 | ² | 104 |
| k | 56 | ³ | 105 |
| l | 57 | | |

Example:

Create a user unit named kPa.

1. When in the menu [323] press Next to move the cursor to the right most position.
2. Press the + key until the character k is displayed.
3. Press Next.
4. Then press the + key until P is displayed and confirm with Next.
5. Repeat until you have entered kPa.

| | |
|--------------------------------------|---------------------|
| 323 User Unit Stp A | |
| Default: | No characters shown |

Communication information

| | |
|----------------------------------|--|
| Modbus Instance no/DeviceNet no: | 43304 43305 43306 43307 43308 43309 |
| Profibus slot/index | 169/208 169/209 169/210 169/211 169/212 169/213 |
| Fieldbus format | UInt |
| Modbus format | UInt |

When sending a unit name you send one character at a time starting at the right most position.

Process Min [324]

This function sets the minimum process value allowed.

| | |
|---|--|
| 324 Process Min Stp A 0 | |
| Default: | 0 |
| Range: | 0.000-10000 (Speed, Torque, F(Speed), F(Torque)) -10000- +10000 (F(AnIn, PT100, F(Bus)) |

Communication information

| | |
|----------------------------------|---------------|
| Modbus Instance no/DeviceNet no: | 43310 |
| Profibus slot/index | 169/214 |
| Fieldbus format | Long, 1=0.001 |
| Modbus format | EInt |

Process Max [325]

This menu is not visible when speed, torque or frequency is selected. The function sets the value of the maximum process value allowed.

| | |
|---|-------------|
| 325 Process Max Stp A 0 | |
| Default: | 0 |
| Range: | 0.000-10000 |

Communication information

| | |
|----------------------------------|---------------|
| Modbus Instance no/DeviceNet no: | 43311 |
| Profibus slot/index | 169/215 |
| Fieldbus format | Long, 1=0.001 |
| Modbus format | EInt |

Ratio [326]

This menu is not visible when speed, frequency or torque is selected. The function sets the ratio between the actual process value and the motor speed so that it has an accurate process value when no feedback signal is used. See Fig. 64.

| | | |
|---|--------|--|
| 326 Ratio Stp A Linear | | |
| Default: | Linear | |
| Linear | 0 | Process is linear related to speed/torque |
| Quadratic | 1 | Process is quadratic related to speed/torque |

Communication information

| | |
|----------------------------------|---------|
| Modbus Instance no/DeviceNet no: | 43312 |
| Profibus slot/index | 169/216 |
| Fieldbus format | UInt |
| Modbus format | UInt |

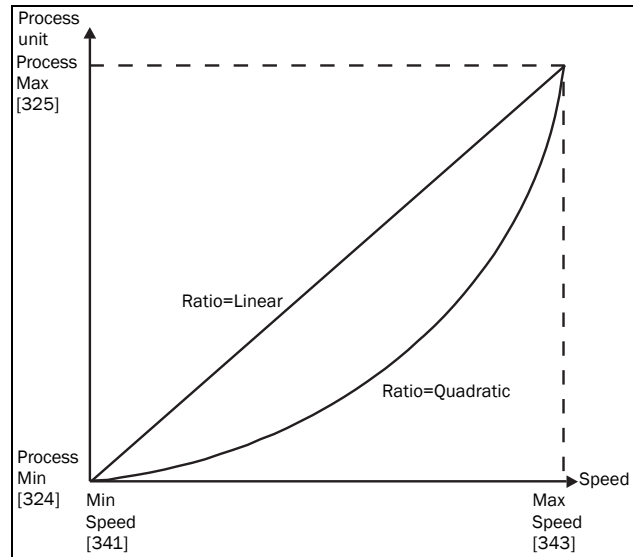

Fig. 64 Ratio

F(Value), Process Min [327]

This function is used for scaling if no sensor is used. It offers you the possibility of increasing the process accuracy by scaling the process values. The process values are scaled by linking them to known data in the AC drive. With F(Value), Proc Min [327] the precise value at which the entered Process Min [324] is valid can be entered.

NOTE: If Speed, Torque or Frequency is chosen in menu [321] Proc Source, menus [322]- [328] are hidden.

| | | |
|---|---------|--|
| 327 F(Val) PrMin Stp A Min | | |
| Default: | Min | |
| Min | -1 | According to Min Speed setting in [341]. |
| Max | -2 | According to Max Speed setting in [343]. |
| 0.000-10000 | 0-10000 | 0.000-10000 |

Communication information

| | |
|----------------------------------|---------------|
| Modbus Instance no/DeviceNet no: | 43313 |
| Profibus slot/index | 169/217 |
| Fieldbus format | Long, 1=1 rpm |
| Modbus format | EInt |

F(Value), Process Max [328]

This function is used for scaling if no sensor is used. It offers you the possibility of increasing the process accuracy by scaling the process values. The process values are scaled by linking them to known data in the AC drive. With F(Value), Proc Max the precise value at which the entered Process Max [525] is valid can be entered.

NOTE: If Speed, Torque or Frequency is chosen in menu [321] Proc Source, menus [322]- [328] are hidden.

| | | |
|--|---------|-------------|
| 328 F(Val) PrMax Stp A Max | | |
| Default: | Max | |
| Min | -1 | Min |
| Max | -2 | Max |
| 0.000-10000 | 0-10000 | 0.000-10000 |

Communication information

| | |
|----------------------------------|---------------|
| Modbus Instance no/DeviceNet no: | 43314 |
| Profibus slot/index | 169/218 |
| Fieldbus format | Long, 1=1 rpm |
| Modbus format | Elnt |

Example

A conveyor belt is used to transport bottles. The required bottle speed needs to be within 10 to 100 bottles/s. Process characteristics:

10 bottles/s = 150 rpm

100 bottles/s = 1500 rpm

The amount of bottles is linearly related to the speed of the conveyor belt.

Set-up:

Process Min [324] = 10

Process Max [325] = 100

Ratio [326] = linear

F(Value), ProcMin [327] = 150

F(Value), ProcMax [328] = 1500

With this set-up, the process data is scaled and linked to known values which results in an accurate control.

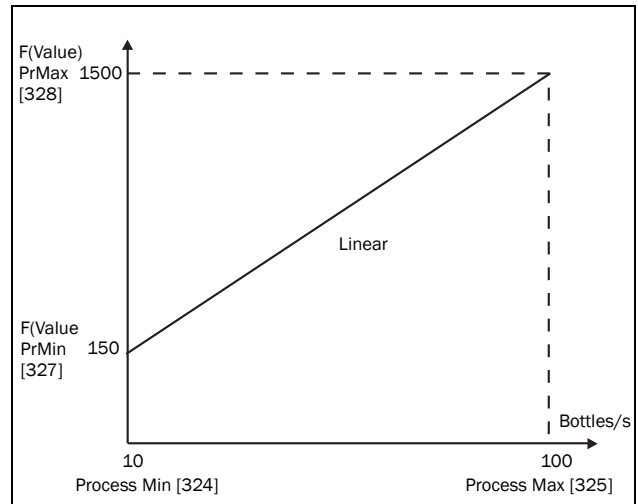

Fig. 65

11.3.3 Start/Stop settings [330]

Submenu with all the functions for acceleration, deceleration, starting, stopping, etc.

Acceleration Time [331]

The acceleration time is defined as the time it takes for the motor to accelerate from 0 rpm to nominal motor speed.

NOTE: If the Acc Time is too short, the motor is accelerated according to the Torque Limit. The actual Acceleration Time may then be longer than the value set.

| | |
|--|----------|
| 331 Acc Time Stp A 10.0s | |
| Default: | 10.0 s |
| Range: | 0-3600 s |

Communication information

| | |
|----------------------------------|----------------|
| Modbus Instance no/DeviceNet no: | 43101 |
| Profibus slot/index | 169/5 |
| Fieldbus format | Long, 1=0.01 s |
| Modbus format | Elnt |

Fig. 66 shows the relationship between nominal motor speed/max speed and the acceleration time. The same is valid for the deceleration time.

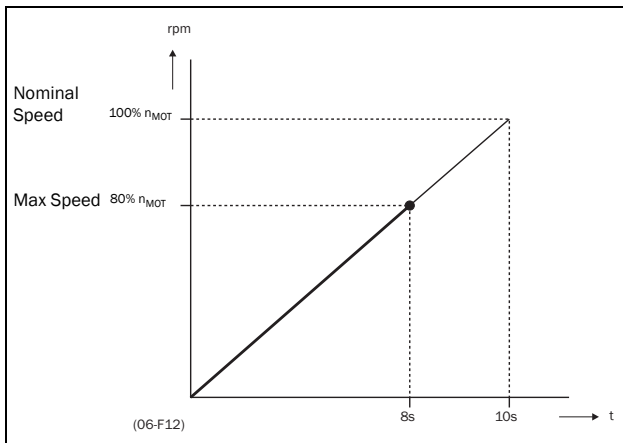

Fig. 66 Acceleration time and maximum speed

Fig. 67 shows the settings of the acceleration and deceleration times with respect to the nominal motor speed.

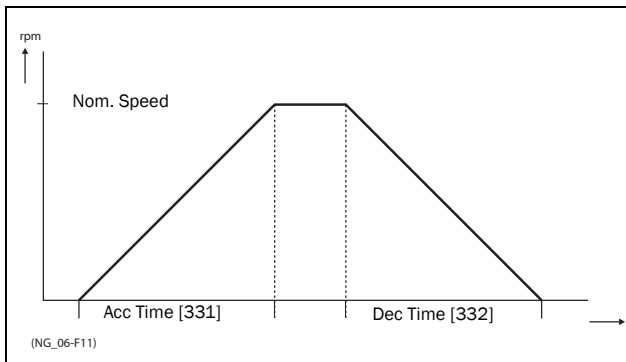

Fig. 67 Acceleration and deceleration times

Deceleration Time [332]

The deceleration time is defined as the time it takes for the motor to decelerate from nominal motor speed to 0 rpm.

| | |
|---------------------|----------|
| 332 Dec Time | |
| Stp A 10.0s | |
| Default: | 10.0 s |
| Range: | 0-3600 s |

Communication information

| | |
|----------------------------------|----------------|
| Modbus Instance no/DeviceNet no: | 43102 |
| Profibus slot/index | 169/6 |
| Fieldbus format | Long, 1=0.01 s |
| Modbus format | EInt |

NOTE: If the Dec Time is too short and the generator energy cannot be dissipated in a brake resistor, the motor is decelerated according to the overvoltage limit. The actual deceleration time may be longer than the value set.

Acceleration Time Motor Potentiometer [333]

It is possible to control the speed of the AC drive using the motor potentiometer function. This function controls the speed with separate up and down commands, over remote signals. The MotPot function has separate ramps settings which can be set in Acc MotPot [333] and Dec MotPot [334].

If the MotPot function is selected, this is the acceleration time for the MotPot up command. The acceleration time is defined as the time it takes for the motor potentiometer value to increase from 0 rpm to nominal speed.

| | |
|-----------------------|-------------|
| 333 Acc MotPot | |
| Stp A 16.0s | |
| Default: | 16.0 s |
| Range: | 0.50-3600 s |

Communication information

| | |
|----------------------------------|----------------|
| Modbus Instance no/DeviceNet no: | 43103 |
| Profibus slot/index | 169/7 |
| Fieldbus format | Long, 1=0.01 s |
| Modbus format | EInt |

Deceleration Time Motor Potentiometer [334]

If the MotPot function is selected, this is the deceleration time for the MotPot down command. The deceleration time is defined as the time it takes for the motor potentiometer value to decrease from nominal speed to 0 rpm.

| | |
|-----------------------|-------------|
| 334 Dec MotPot | |
| Stp A 16.0s | |
| Default: | 16.0 s |
| Range: | 0.50-3600 s |

Communication information

| | |
|----------------------------------|--------------|
| Modbus Instance no/DeviceNet no: | 43104 |
| Profibus slot/index | 169/8 |
| Fieldbus format | Long, 1=0.01 |
| Modbus format | EInt |

Acceleration Time to Minimum Speed [335]

If minimum speed, [341]>0 rpm, is used in an application, the AC drive uses separate ramp times below this level. With Acc>MinSpeed [335] and Dec<MinSpeed [336] you can set the required ramp times. Short times can be used to prevent damage and excessive pump wear due too little lubrication at lower speeds. Longer times can be used to fill up a system smoothly and prevent water hammer due to rapidly exhausting air from the pipe system.

If a Minimum speed is programmed, this parameter will be used to set the acceleration time to the minimum speed at a run command. The ramp time is defined as the time it takes for the motor to accelerate from 0 rpm to nominal motor speed.

| | |
|---|----------|
| 335 Acc>Min Spd Stp _A 10.0s | |
| Default: | 10.0 s |
| Range: | 0-3600 s |

Communication information

| | |
|----------------------------------|--------------|
| Modbus Instance no/DeviceNet no: | 43105 |
| Profibus slot/index | 169/9 |
| Fieldbus format | Long, 1=0.01 |
| Modbus format | Elnt |

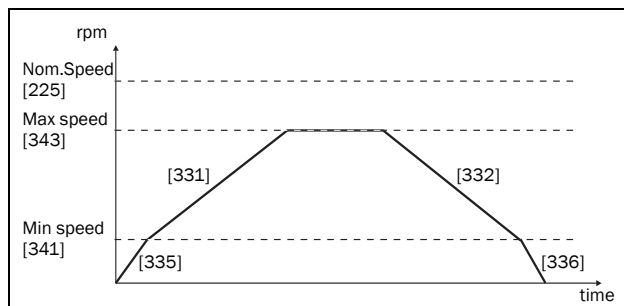

Fig. 68

Deceleration Time from Minimum Speed [336]

If a minimum speed is programmed, this parameter will be used to set the deceleration time from the minimum speed to 0 rpm at a stop command. The ramp time is defined as the time it takes for the motor to decelerate from the nominal motor speed to 0 rpm.

| | |
|---|----------|
| 336 Dec<Min Spd Stp _A 10.0s | |
| Default: | 10.0 s |
| Range: | 0-3600 s |

Communication information

| | |
|----------------------------------|----------------|
| Modbus Instance no/DeviceNet no: | 43106 |
| Profibus slot/index | 169/10 |
| Fieldbus format | Long, 1=0.01 s |
| Modbus format | Elnt |

Acceleration Ramp Type [337]

Sets the type of all the acceleration ramps in a parameter set. See Fig. 69. Depending on the acceleration and deceleration requirements for the application, the shape of both the ramps can be selected. For applications where speed changes need to be started and stopped smoothly, such as a conveyor belt with materials that can drop following a quick speed change, the ramp shape can be adapted to a S-shape and prevent speed change shocks. For applications that are not critical in this, the speed change can be fully linear over the complete range.

| | | |
|---|--------|----------------------------|
| 337 Acc Rmp Stp _A Linear | | |
| Default: | Linear | |
| Linear | 0 | Linear acceleration ramp. |
| S-Curve | 1 | S-shape acceleration ramp. |

NOTE: For S-curve ramps the ramp times, [331] and [332], defines the maximum acceleration and deceleration rated, i.e. linear part of S-curve, just as for the linear ramps. The S-curves are implemented so that for a speed step below sync speed the ramps are fully S-shaped while for larger steps the middle part will be linear. Therefore will a S-curve ramp from 0 –sync speed take 2 x Time while a step from 0–2 x sync speed will take 3 x Time (middle part 0.5sync speed – 1.5sync speed linear). Also valid for menu [337], D.eceleration ramp type.

Communication information

| | |
|----------------------------------|--------|
| Modbus Instance no/DeviceNet no: | 43107 |
| Profibus slot/index | 169/11 |
| Fieldbus format | UInt |
| Modbus format | UInt |

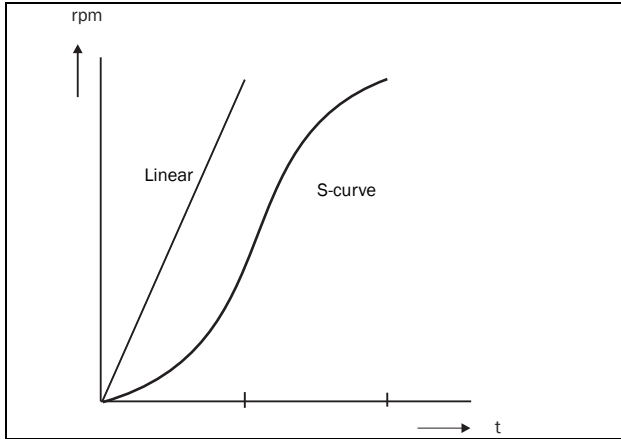

Fig. 69 Shape of acceleration ramp

Deceleration Ramp Type [338]

Sets the ramp type of all deceleration parameters in a parameter set Fig. 70.

| | |
|--|--------------------|
| 338 Dec Rmp Stp A Linear | |
| Default: | Linear |
| Selection: | Same as menu [337] |

Communication information

| | |
|----------------------------------|--------|
| Modbus Instance no/DeviceNet no: | 43108 |
| Profibus slot/index | 169/12 |
| Fieldbus format | UInt |
| Modbus format | UInt |

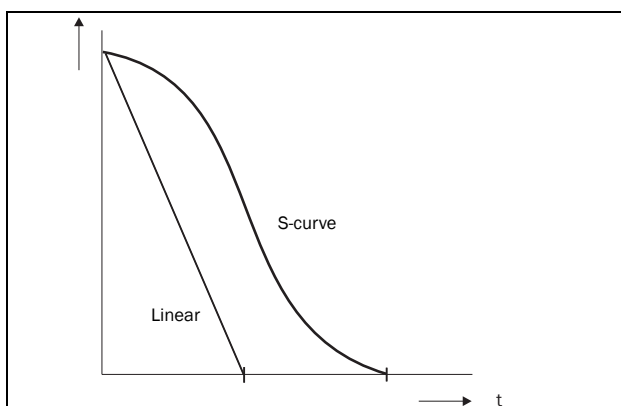

Fig. 70 Shape of deceleration ramp

Start Mode [339]

Sets the way of starting the motor when a run command is given.

| | |
|--|---|
| 339 Start Mode Stp A Normal DC | |
| Default: | Normal DC |
| Fast | 0 The motor flux increases gradually. The motor shaft starts rotating immediately once the Run command is given. |
| Normal DC | 1 After a Run command the motor will be magnetised first and the stator resistance is measured. Depending on the motor time constant and the size of the motor it can take up to 1.3 s before the motor shaft starts to rotate. This will provide better control of the motor when starting. |

Communication information

| | |
|----------------------------------|--------|
| Modbus Instance no/DeviceNet no: | 43109 |
| Profibus slot/index | 169/13 |
| Fieldbus format | UInt |
| Modbus format | UInt |

Spinstart [33A]

The spinstart will smoothly start a motor which is already rotating by catching the motor at the actual speed and control it to the desired speed. If in an application, such as an exhausting fan, the motor shaft is already rotating due to external conditions, a smooth start of the application is required to prevent excessive wear. With the spinstart=on, the actual control of the motor is delayed due to detecting the actual speed and rotation direction, which depend on motor size, running conditions of the motor before the Spinstart, inertia of the application, etc. Depending on the motor electrical time constant and the size of the motor, it can take maximum a couple of minutes before the motor is caught.

| | |
|---|---|
| 33A Spinstart Stp A Off | |
| Default: | Off |
| Off | 0 No spinstart. If the motor is already running the AC drive can trip or will start with high current. |
| On | 1 Spinstart will allow the start of a running motor without tripping or high inrush currents. |

Communication information

| | |
|----------------------------------|--------|
| Modbus Instance no/DeviceNet no: | 43110 |
| Profibus slot/index | 169/14 |
| Fieldbus format | UInt |
| Modbus format | UInt |

Stop Mode [33B]

When the AC drive is stopped, different methods to come to a standstill can be selected in order to optimize the stop and prevent unnecessary wear. Stop Mode sets the way of stopping the motor when a Stop command is given.

| | | |
|------------------------|-------|--|
| 33B Stop Mode | | |
| Stp ^A Decel | | |
| Default: | Decel | |
| Decel | 0 | The motor decelerates to 0 rpm according to the set deceleration time. |
| Coast | 1 | The motor freewheels naturally to 0 rpm. |

Communication information

| | |
|----------------------------------|--------|
| Modbus Instance no/DeviceNet no: | 43111 |
| Profibus slot/index | 169/15 |
| Fieldbus format | UInt |
| Modbus format | UInt |

11.3.4 Mechanical brake control

The four brake-related menus [33C] to [33F] can be used to control mechanical brakes e.g. to handle basic hoisting functions. When hoisting a load generally a mechanical brake holds the load when the AC drive is not running. To prevent the load from falling down a holding torque must be initiated before the mechanical brake is released. On the other hand when stopping hoisting the brake must be activated before the holding torque is removed.

Support is included for a Brake Acknowledge signal via a digital input. It is monitored using a brake fault time parameter. Additional output and trip/warning signals are also included. The acknowledge signal is either connected from the brake contactor or from a proximity switch on the brake.

The brake acknowledge signal can also be used to improve safety by preventing hoist falling load in case the brake is not engaged when stopping.

Brake not released - Brake Fault trip

During start and running the brake acknowledge signal is compared to the actual brake output signal and if no acknowledge, i.e. brake not released, while brake out-

put is high for the Brake Fault time [33H], then a Brake trip is generated.

Brake not engaged - Brake Warning and continued operation (keep torque)

The brake acknowledge signal is compared to the actual brake output signal at stop. If acknowledge is still active, i.e. brake not engaged, while brake output is low for the Brake Engage time [33E] then a Brake warning is generated and the torque is kept, i.e. prolonging normal brake engage mode, until brake closes or an emergency action is needed by the operator, such as setting down the load.

Brake Release Time [33C]

The Brake Release Time sets the time the AC drive delays before ramping up to whatever final reference value is selected. During this time a predefined speed can be generated to hold the load where after the mechanical brake finally releases. This speed can be selected at Release Speed, [33D]. Immediate after the brake release time expiration the brake lift signal is set. The user can set a digital output or relay to the function Brake. This output or relay can control the mechanical brake.

| | |
|------------------------|-------------|
| 33C Brk Release | |
| Stp ^A 0.00s | |
| Default: | 0.00 s |
| Range: | 0.00–3.00 s |

Communication information

| | |
|----------------------------------|----------------|
| Modbus Instance no/DeviceNet no: | 43112 |
| Profibus slot/index | 169/16 |
| Fieldbus format | Long, 1=0.01 s |
| Modbus format | EInt |

Fig. 71 shows the relation between the four Brake functions.

- Brake Release Time [33C]
- Start Speed [33D]
- Brake Engage Time [33E]
- Brake Wait Time [33F]

The correct time setting depends on the maximum load and the properties of the mechanical brake. During the brake release time it is possible to apply extra holding torque by setting a start speed reference with the function start speed [33D]

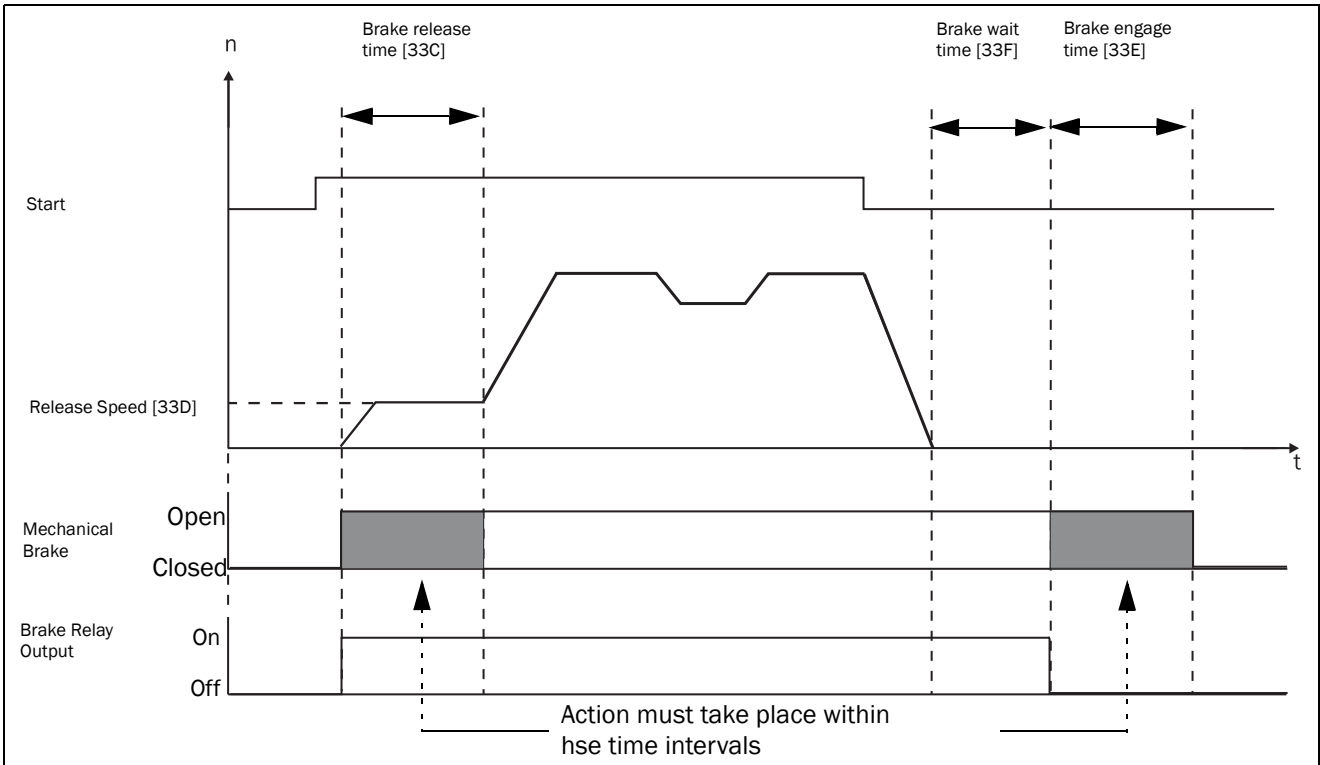

Fig. 71 Brake Output functions

NOTE: Although this function is designed to operate a mechanical brake via the digital outputs or relays (set to brake function) controlling a mechanical brake, it can also be used without a mechanical brake and hold the load in a fixed position.

Release Speed [33D]

The release speed only operates with the brake function: brake release [33C]. The release speed is the initial speed reference during the brake release time. The torque reference is initialized to 90% of T_{NOM} to ensure that the load is held in place.

| | |
|---|--|
| 33D Release Spd Stp ^A 0rpm | |
| Default: | 0 rpm |
| Range: | - 4x Sync. Speed to 4x Sync. |
| Depend on: | 4xmotor sync speed, 1500 rpm for 1470 rpm motor. |

Communication information

| | |
|----------------------------------|--------------|
| Modbus Instance no/DeviceNet no: | 43113 |
| Profibus slot/index | 169/17 |
| Fieldbus format | Int, 1=1 rpm |
| Modbus format | Int, 1=1 rpm |

Brake Engage Time [33E]

The brake engage time is the time the load is held while the mechanical brake engages. It is also used to get a firm stop when transmissions, etc. cause "whiplash" effects. In other words, it compensates for the time it takes to engage a mechanical brake.

| | |
|---|-------------|
| 33E Brk Engage Stp ^A 0.00s | |
| Default: | 0.00 s |
| Range: | 0.00-3.00 s |

Communication information

| | |
|----------------------------------|----------------|
| Modbus Instance no/DeviceNet no: | 43114 |
| Profibus slot/index | 169/18 |
| Fieldbus format | Long, 1=0.01 s |
| Modbus format | EInt |

Wait Before Brake Time [33F]

The brake wait time is the time to keep brake open and to hold the load, either in order to be able to speed up immediately, or to stop and engage the brake.

| | |
|---|-------------|
| 33F Brk Wait Stp _A 0.00s | |
| Default: | 0.00 s |
| Range: | 0.00–30.0 s |

Communication information

| | |
|----------------------------------|----------------|
| Modbus Instance no/DeviceNet no: | 43115 |
| Profibus slot/index | 169/19 |
| Fieldbus format | Long, 1=0.01 s |
| Modbus format | EInt |

Vector Brake [33G]

Braking by increasing the internal electrical losses in the motor.

| | | |
|---|-----|--|
| 33G Vector Brake Stp _A Off | | |
| Default: | Off | |
| Off | 0 | Vector brake switched off. AC drive brakes normal with voltage limit on the DC link. |
| On | 1 | Maximum AC drive current (I_{CL}) is available for braking. |

Communication information

| | |
|----------------------------------|--------|
| Modbus Instance no/DeviceNet no: | 43116 |
| Profibus slot/index | 169/20 |
| Fieldbus format | UInt |
| Modbus format | UInt |

Brake Fault trip time [33H]

The “Brake Fault trip time” for “Brake not released” function is specified in this menu.

| | |
|--|--------------|
| 33H Brk Fault Stp _A 1.00s | |
| Default: | 1.00s |
| Range: | 0.00 - 5.00s |

Communication information

| | |
|----------------------------------|--------------|
| Modbus Instance no/DeviceNet no: | 43117 |
| Profibus slot/index | 169/21 |
| Fieldbus format | Long, 1=0.1s |
| Modbus format | EInt |

Note: The Brake Fault trip time should be set to longer time than the Brake release time[33C].

The “Brake not engaged” warning is using the setting of parameter “Brake Engaged time [33E]”. Following Figure shows principle of brake operation for fault during run (left) and during stop (right).

Release torque [33I]

The Brake Release Time [33C] sets the time the VSD delays before ramping up to whatever final speed reference value is selected, to allow the brake to be fully opened. During this time a holding torque to prevent roll-back of the load can be activated. The parameter Release Torque [33I] is used for this purpose.

The release torque initiates the torque reference from the speed controller during the Brake Release Time [33C]. The release torque defines a minimum level of release (holding) torque. The set release torque is internally overruled if the actual required holding torque measured at the previous closing of brake is higher. The release torque is set with sign in order to define the holding torque direction.

| | |
|---|---------------|
| 33I Release Trq Stp _A 0% | |
| Default: | 0% |
| Range: | -400% to 400% |

Communication information

| | |
|----------------------------------|-------------|
| Modbus Instance no/DeviceNet no: | 43118 |
| Profibus slot/index | 169/22 |
| Fieldbus format | Long, 1=1H% |
| Modbus format | EInt |

Note! Function is deactivated if set to 0%.

Note! Release Torque [33I] has priority over torque reference initialization by Release Speed [33D].

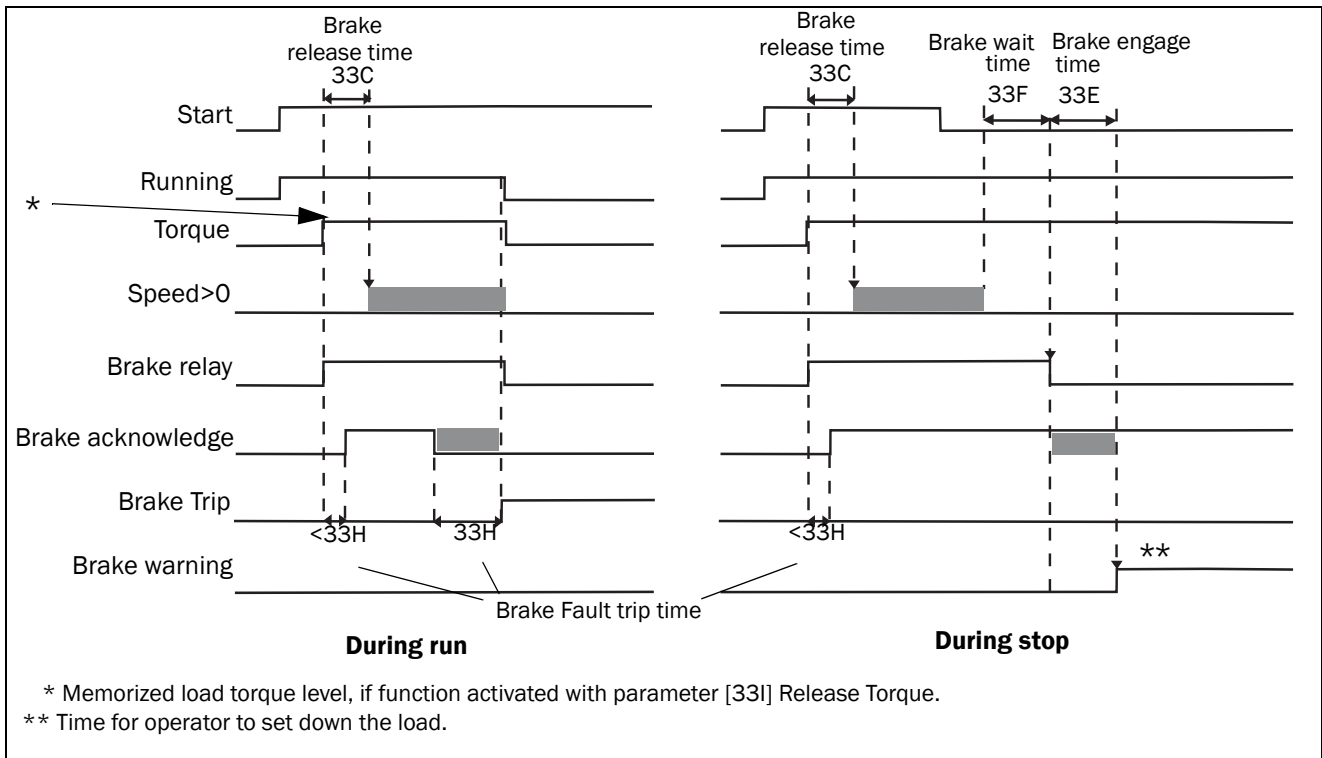

Fig. 72 Principle of Brake operation for fault during run and during stop

11.3.5 Speed [340]

Menu with all parameters for settings regarding to speeds, such as Min/Max speeds, Jog speeds, Skip speeds.

Minimum Speed [341]

Sets the minimum speed. The minimum speed will operate as an absolute lower limit. Used to ensure the motor does not run below a certain speed and to maintain a certain performance.

| | |
|---------------|--|
| | 341 Min Speed Stp _A 0rpm |
| Default: | 0 rpm |
| Range: | 0 - Max Speed |
| Dependent on: | Set/View ref [310] |

NOTE: A lower speed value than the set minimum speed can be shown in the display due to motor slip.

Communication information

| | |
|----------------------------------|--------------|
| Modbus Instance no/DeviceNet no: | 43121 |
| Profibus slot/index | 169/25 |
| Fieldbus format | Int, 1=1 rpm |
| Modbus format | Int, 1=1 rpm |

Stop/Sleep when less than Minimum Speed [342]

With this function it is possible to put the AC drive in "sleep mode" when it is running at minimum speed for the length of time set, due to process value feedback or a reference value that corresponds to a speed lower than the min speed set. The AC drive will go into sleep mode after programmed time. When the reference signal or process value feedback raises the required speed value above the min speed value, the AC drive will automatically wake up and ramp up to the required speed.

NOTE: Menu [386] has higher priority than menu [342].

| | |
|----------|---|
| | 342 Stp<MinSpd Stp _A Off |
| Default: | Off |
| Off | 0 Off |
| 1-3600 | 1-3600 1-3600 s |

Communication information

| | |
|----------------------------------|----------------|
| Modbus Instance no/DeviceNet no: | 43122 |
| Profibus slot/index | 169/26 |
| Fieldbus format | Long, 1=0.01 s |
| Modbus format | EInt |

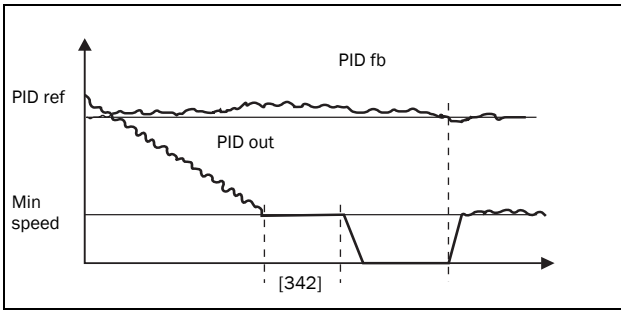

Fig. 73

Maximum Speed [343]

Sets the maximum speed. The maximum speed will operate as an absolute maximum limit. This parameter is used to prevent damage due to high speed. The synchronous speed (Sync-spд) is determined by the parameter motor speed [225].

| | | |
|---|----------|--|
| 343 Max Speed Stp A Sync Speed | | |
| Default: | | Sync Speed |
| Sync Speed | 0 | Synchronous speed, i.e. no load speed, at nominal frequency. |
| 1-24000rpm | 1- 24000 | Min Speed - 4 x Motor Sync Speed |

Communication information

| | |
|----------------------------------|--------------|
| Modbus Instance no/DeviceNet no: | 43123 |
| Profibus slot/index | 169/27 |
| Fieldbus format | Int, 1=1 rpm |
| Modbus format | UInt |

NOTE: It is not possible to set the maximum speed lower than the minimum speed.

Note: Maximum speed [343] has priority over Min Speed [341], i.e. if [343] is set below [341] then the drive will run at [343] Max Speed with acceleration times given by [335] and [336] respectively.

Skip Speed 1 Low [344]

Within the Skip Speed range High to Low, the speed cannot be constant in order to avoid mechanical resonance in the AC drive system.

When Skip Speed Low \leq Ref Speed \leq Skip Speed High, then Output Speed=Skip Speed HI during deceleration and Output Speed=Skip Speed LO during acceleration. Fig. 74 shows the function of skip speed hi and low.

Between Skip Speed HI and LO, the speed changes with the set acceleration and deceleration times. Skipspd1 LO sets the lower value for the 1st skip range.

| | |
|--|--------------------------|
| 344 SkipSpд 1 Lo Stp A 0rpm | |
| Default: | 0 rpm |
| Range: | 0 - 4 x Motor Sync Speed |

Communication information

| | |
|----------------------------------|--------|
| Modbus Instance no/DeviceNet no: | 43124 |
| Profibus slot/index | 169/28 |
| Fieldbus format | Int |
| Modbus format | Int |

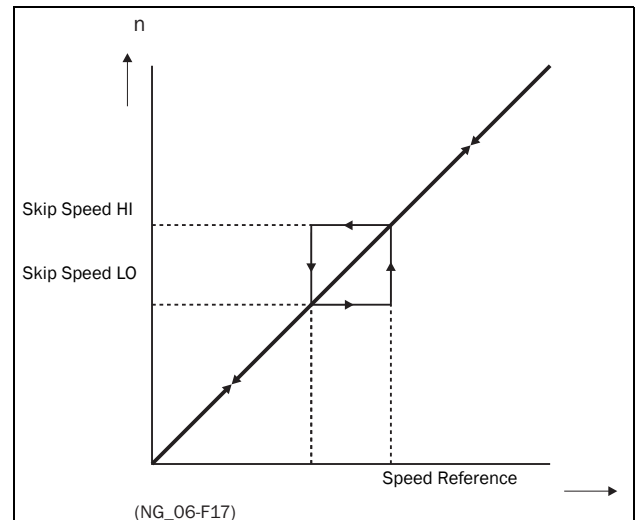

Fig. 74 Skip Speed

NOTE: The two Skip Speed ranges may be overlapped.

Skip Speed 1 High [345]

Skipspd1 HI sets the higher value for the 1st skip range.

| | |
|--|--------------------|
| 345 SkipSpd 1 Hi Stp A 0rpm | |
| Default: | 0 rpm |
| Range: | 0 – 4 x Sync Speed |

Communication information

| | |
|----------------------------------|--------|
| Modbus Instance no/DeviceNet no: | 43125 |
| Profibus slot/index | 169/29 |
| Fieldbus format | Int |
| Modbus format | Int |

Skip Speed 2 Low [346]

The same function as menu [344] for the 2nd skip range.

| | |
|--|--------------------------|
| 346 SkipSpd 2 Lo Stp A 0rpm | |
| Default: | 0 rpm |
| Range: | 0 – 4 x Motor Sync Speed |

Communication information

| | |
|----------------------------------|--------------|
| Modbus Instance no/DeviceNet no: | 43126 |
| Profibus slot/index | 169/30 |
| Fieldbus format | Int, 1=1 rpm |
| Modbus format | Int, 1=1 rpm |

Skip Speed 2 High [347]

The same function as menu [345] for the 2nd skip range.

| | |
|--|--------------------------|
| 347 SkipSpd 2 Hi Stp A 0rpm | |
| Default: | 0 rpm |
| Range: | 0 – 4 x Motor Sync Speed |

Communication information

| | |
|----------------------------------|--------------|
| Modbus Instance no/DeviceNet no: | 43127 |
| Profibus slot/index | 169/31 |
| Fieldbus format | Int, 1=1 rpm |
| Modbus format | Int, 1=1 rpm |

Jog Speed [348]

The Jog Speed function is activated by one of the digital inputs. The digital input must be set to the Jog function [520]. The Jog command/function will automatically generate a run command as long as the Jog command/function is active. The rotation is determined by the polarity of the set Jog Speed.

Example

If Jog Speed = -10, this will give a Run Left command at 10 rpm regardless of RunL or RunR commands. Fig. 75 shows the function of the Jog command/function.

| | |
|--|--|
| 348 Jog Speed Stp A 50rpm | |
| Default: | 50 rpm |
| Range: | -4 x motor sync speed to +4 x motor sync speed |
| Dependent on: | Defined motor sync speed. Max = 400%, normally max=AC drive I_{max} /motor I_{nom} x 100%. |

Communication information

| | |
|----------------------------------|--------|
| Modbus Instance no/DeviceNet no: | 43128 |
| Profibus slot/index | 169/32 |
| Fieldbus format | Int |
| Modbus format | Int |

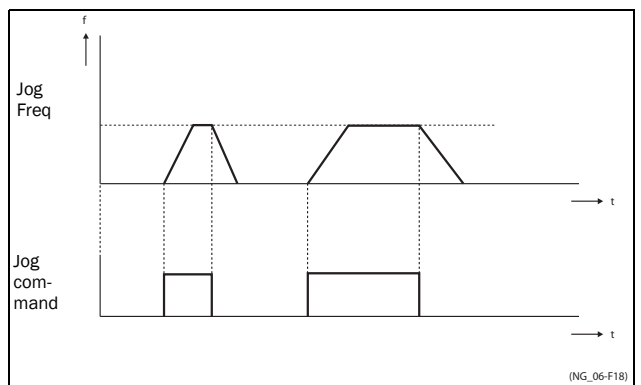

Fig. 75 Jog command

11.3.6 Torques [350]

Menu with all parameters for torque settings.

Maximum Torque [351]

Sets the maximum torque. This Maximum Torque operates as an upper torque limit. A Speed Reference is always necessary to run the motor.

$$T_{MOT}(Nm) = \frac{P_{MOT}(kw) \times 9550}{n_{MOT}(rpm)}$$

| | |
|---|-------------------------------------|
| 351 Max Torque Stp A 120% | |
| Default: | 120% calculated from the motor data |
| Range: | 0-400% |

Communication information

| | |
|----------------------------------|------------|
| Modbus Instance no/DeviceNet no: | 43141 |
| Profibus slot/index | 169/45 |
| Fieldbus format | Long, 1=1% |
| Modbus format | EInt |

NOTE: The Max Torque parameter will limit the maximum output current of the AC drive following the relation: 100% T_{mot} corresponds to 100% I_{mot}. The maximum possible setting for parameter 351 is limited by I_{nom}/I_{mot} x 120%, but not higher than 400%.

NOTE: The power loss in the motor will increase by the square of the torque when operating above 100%. 400% torque will result in 1600% power loss, which will increase the motor temperature very quickly.

IxR Compensation [352]

This function compensates for the drop in voltage over different resistances such as (very) long motor cables, chokes and motor stator by increasing the output voltage at a constant frequency. IxR Compensation is most important at low frequencies and is used to obtain a higher starting torque. The maximum voltage increase is 25% of the nominal output voltage. See Fig. 76.

Selecting "Automatic" will use the optimal value according to the internal model of motor. "User-Defined" can be selected when the start conditions of the application do not change and a high starting torque is always required. A fixed IxR Compensation value can be set in the menu [353].

NOTE: This menu is visible only in V/Hz mode.

| | |
|--|---------------------------------------|
| 352 IxR Comp Stp A Off | |
| Default: | Off |
| Off | 0 Function disabled |
| Automatic | 1 Automatic compensation |
| User Defined | 2 User defined value in percent. |

Communication information

| | |
|----------------------------------|--------|
| Modbus Instance no/DeviceNet no: | 43142 |
| Profibus slot/index | 169/46 |
| Fieldbus format | UInt |
| Modbus format | UInt |

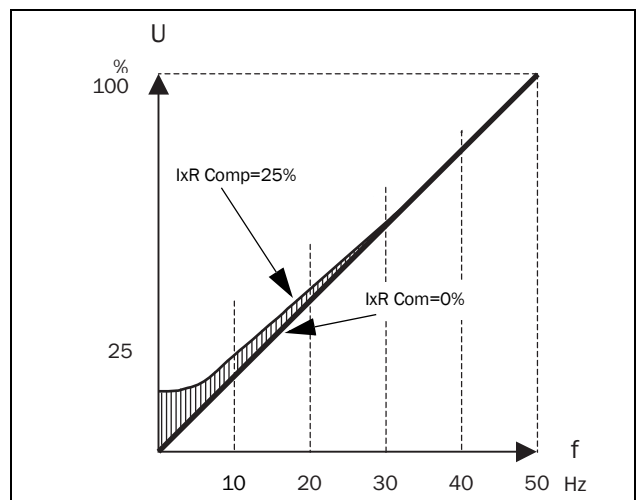

Fig. 76 IxR Comp at Linear V/Hz curve

IxR Comp_user [353]

Only visible if User-Defined is selected in previous menu.

| | |
|---|---|
| 353 IxR CompUser Stp A 0.0% | |
| Default: | 0.0% |
| Range: | 0-25% x U _{NOM} (0.1% of resolution) |

Communication information

| | |
|----------------------------------|--------|
| Modbus Instance no/DeviceNet no: | 43143 |
| Profibus slot/index | 169/47 |
| Fieldbus format | Long |
| Modbus format | EInt |

NOTE: A too high level of IxR Compensation could cause motor saturation. This can cause a "Power Fault" trip. The effect of IxR Compensation is stronger with higher power motors.

NOTE: The motor may be overheated at low speed. Therefore it is important that the Motor I²t Current [232] is set correctly.

Flux Optimization [354]

Flux Optimization reduces the energy consumption and the motor noise, at low or no load conditions.

Flux Optimization automatically decreases the V/Hz ratio, depending on the actual load of the motor when the process is in a steady situation. Fig. 77 shows the area within which the Flux Optimization is active.

| | | |
|-----------------------------------|---|-------------------|
| 354 Flux optim StpA Off | | |
| Default: | | Off |
| Off | 0 | Function disabled |
| On | 1 | Function enabled |

Communication information

| | |
|----------------------------------|--------|
| Modbus Instance no/DeviceNet no: | 43144 |
| Profibus slot/index | 169/48 |
| Fieldbus format | UInt |
| Modbus format | UInt |

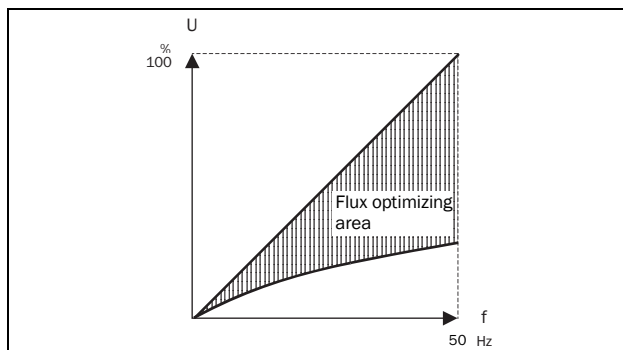

Fig. 77 Flux Optimizing

NOTE: Flux optimization works best at stable situations in slow changing processes.

Maximum power [355]

Sets maximum power. Can be used for limiting motor power in field weakening operation. This function operates as an upper power limit and internally limits the parameter Max Torque [351] according to :
 $T_{limit} = P_{limit}[\%] / (\text{Actual Speed} / \text{Sync Speed})$

| | | |
|----------------------------------|---------|---------------------------------|
| 355 Max Power StpA Off | | |
| Default: | | Off |
| Off | 0 | Off. No power limit |
| 1 - 400 | 1 - 400 | 1 - 400% of motor nominal power |

NOTE: The maximum possible setting for parameter 355 is limited by $I_{NOM}/I_{MOT} \times 120\%$, but not higher than 400%.

Communication information

| | |
|----------------------------------|------------|
| Modbus Instance no/DeviceNet no: | 43145 |
| Profibus slot/index | 169/49 |
| Fieldbus format | Long, 1=1% |
| Modbus format | EInt |

11.3.7 Preset References [360]

Motor Potentiometer [361]

Sets the properties of the motor potentiometer function. See the parameter DigIn1 [521] for the selection of the motor potentiometer function.

| 361 Motor Pot Stp _A Non Volatile | |
|---|---|
| Default: | Non Volatile |
| Volatile | 0 After a stop, trip or power down, the AC drive will start always from zero speed (or minimum speed, if selected). |
| Non volatile | 1 Non Volatile. After a stop, trip or power down of the AC drive, the reference value at the moment of the stop will be memorized. After a new start command the output speed will resume to this saved value. |

Communication information

| | |
|----------------------------------|--------|
| Modbus Instance no/DeviceNet no: | 43131 |
| Profibus slot/index | 169/35 |
| Fieldbus format | UInt |
| Modbus format | UInt |

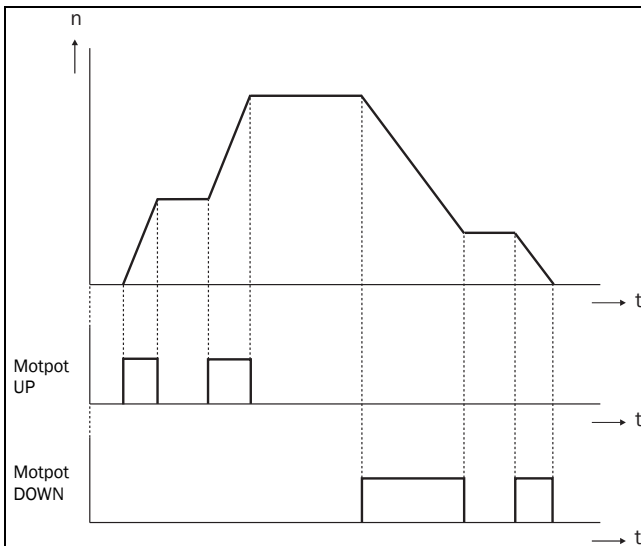

Fig. 78 MotPot function

Preset Ref 1 [362] to Preset Ref 7 [368]

Preset speeds have priority over the analogue inputs. Preset speeds are activated by the digital inputs. The digital inputs must be set to the function Pres. Ref 1, Pres. Ref 2 or Pres. Ref 4.

Depending on the number of digital inputs used, up to 7 preset speeds can be activated per parameter set. Using all the parameter sets, up to 28 preset speeds are possible.

| 362 Preset Ref 1 Stp _A 0rpm | |
|--|---|
| Default: | Speed, 0 rpm |
| Dependent on: | Process Source [321] and Process Unit [322] |
| Speed mode | 0 - max speed [343] |
| Torque mode | 0 - max torque [351] |
| Other modes | Min according to menu [324] - max according to menu [325] |

Communication information

| | |
|----------------------------------|---------------|
| Modbus Instance no/DeviceNet no: | 43132-43138 |
| Profibus slot/index | 169/36-169/42 |
| Fieldbus format | Long |
| Modbus format | Elnt |

The same settings are valid for the menus:

- [363] Preset Ref 2, with default 250 rpm
- [364] Preset Ref 3, with default 500 rpm
- [365] Preset Ref 4, with default 750 rpm
- [366] Preset Ref 5, with default 1000 rpm
- [367] Preset Ref 6, with default 1250 rpm
- [368] Preset Ref 7, with default 1500 rpm

The selection of the presets is as in Table 24.

Table 24

| Preset Ctrl3 | Preset Ctrl2 | Preset Ctrl1 | Output Speed |
|-----------------|-----------------|-----------------|--------------------|
| 0 | 0 | 0 | Analogue reference |
| 0 | 0 | 1 ¹⁾ | Preset Ref 1 |
| 0 | 1 ¹⁾ | 0 | Preset Ref 2 |
| 0 | 1 | 1 | Preset Ref 3 |
| 1 ¹⁾ | 0 | 0 | Preset Ref 4 |
| 1 | 0 | 1 | Preset Ref 5 |
| 1 | 1 | 0 | Preset Ref 6 |
| 1 | 1 | 1 | Preset Ref 7 |

¹⁾= selected if only one preset reference is active

1 = active input

0 = non active input

NOTE: If only Preset Ctrl3 is active, then the Preset Ref 4 can be selected. If Presets Ctrl2 and 3 are active, then the Preset Ref 2, 4 and 6 can be selected.

Keyboard reference mode [369]

This parameter sets how the reference value [310] is edited.

| | |
|--|--------|
| 369 Key Ref Mode | |
| Stp A MotPot | |
| Default: | MotPot |
| Normal | 0 |
| The reference value is edited as a normal parameter (the new reference value is activated when Enter is pressed after the value has been changed). The Acc Time [331] and Dec Time [332] are used. | |
| MotPot | 1 |
| The reference value is edited using the motor potentiometer function (the new reference value is activated directly when the key + or - is pressed). The Acc MotPot [333] and Dec MotPot [334] are used. | |

Communication information

| | |
|----------------------------------|--------|
| Modbus Instance no/DeviceNet no: | 43139 |
| Profibus slot/index | 169/43 |
| Fieldbus format | UInt |
| Modbus format | UInt |

NOTE: When Key Ref Mode is set to MotPot, the reference value ramp times are according to the Acc MotPot [333] and Dec MotPot [334] settings. Actual speed ramp will be limited according to Acc Time [331] and Dec Time [332].

11.3.8 PI Speed Control [370]

The AC drive has an internal speed controller, which is used to keep the shaft speed equal to the set speed reference. This internal speed controller works without an external feedback.

With the parameters speed P gain [372] and speed I time [373] the controller can be optimized manually.

Speed PI Autotune [371]

The function speed autotune will perform a torque step change, and measures the reaction on shaft speed.

It automatically sets the internal speed I time to its optimum value. The speed PI autotune must be done during operation with the motor load connected and the motor running. "Spd PI Auto" will be flashing in the display during the autotune operation. When the test is successfully concluded, the display will show "Spd PI OK!" for 3 s.

| | |
|------------------------|-----|
| 371 Spd PI Auto | |
| Stp A Off | |
| Default: | Off |
| Off | 0 |
| On | 1 |

Communication information

| | |
|----------------------------------|--------|
| Modbus Instance no/DeviceNet no: | 43151 |
| Profibus slot/index | 169/55 |
| Fieldbus format | UInt |
| Modbus format | UInt |

NOTE: Run the autotune at speed lower than 80% of the nominal motor speed. Otherwise autotune will fail.

NOTE: The setting will automatically return to Off when the autotuning is finished.

NOTE: This menu is only visible if AC drive Mode = Speed or V/Hz.

Speed P Gain [372]

For adjusting the P gain of the internal speed controller. The speed P gain must be manually tuned for a faster reaction to load changes. The speed P gain can be increased until there is audible noise from the motor and then decreased until the noise disappears.

| | |
|-------------------------------|----------|
| 372 Spd P Gain StpA | |
| Default: | See note |
| Range: | 0.0–60.0 |

Communication information

| | |
|----------------------------------|-------------|
| Modbus Instance no/DeviceNet no: | 43152 |
| Profibus slot/index | 169/56 |
| Fieldbus format | Long, 1=0.1 |
| Modbus format | Elnt |

Speed I Time [373]

To adjust the time of the internal speed controller see parameter Speed PI Autotune [371].

| | |
|-------------------------------|------------|
| 373 Spd I Time StpA | |
| Default: | See note |
| Range: | 0.05–100 s |

Communication information

| | |
|----------------------------------|----------------|
| Modbus Instance no/DeviceNet no: | 43153 |
| Profibus slot/index | 169/57 |
| Fieldbus format | Long, 1=0.01 s |
| Modbus format | Elnt |

NOTE: The default settings are calculated for a standard 4-pole motor without load according to the nominal power of the AC drive.

11.3.9 PID Process Control [380]

The PID controller is used to control an external process via a feedback signal. The reference value can be set via analogue input AnIn1, at the Control Panel [310] by using a Preset Reference, or via serial communication. The feedback signal (actual value) must be connected to an analogue input that is set to the function Process Value.

Process PID Control [381]

This function enables the PID controller and defines the response to a changed feedback signal.

| | | |
|---|-----|--|
| 381 PID Control StpA Off | | |
| Default: | Off | |
| Off | 0 | PID control deactivated. |
| On | 1 | The speed increases when the feedback value decreases. PID settings according to menus [381] to [385]. |
| Invert | 2 | The speed decreases when the feedback value decreases. PID settings according to menus [383] to [385]. |

Communication information

| | |
|----------------------------------|--------|
| Modbus Instance no/DeviceNet no: | 43154 |
| Profibus slot/index | 169/58 |
| Fieldbus format | UInt |
| Modbus format | UInt |

PID P Gain [383]

Setting the P gain for the PID controller.

| | |
|--|----------|
| 383 PID P Gain StpA 1.0 | |
| Default: | 1.0 |
| Range: | 0.0–30.0 |

Communication information

| | |
|----------------------------------|-------------|
| Modbus Instance no/DeviceNet no: | 43156 |
| Profibus slot/index | 169/60 |
| Fieldbus format | Long, 1=0.1 |
| Modbus format | Elnt |

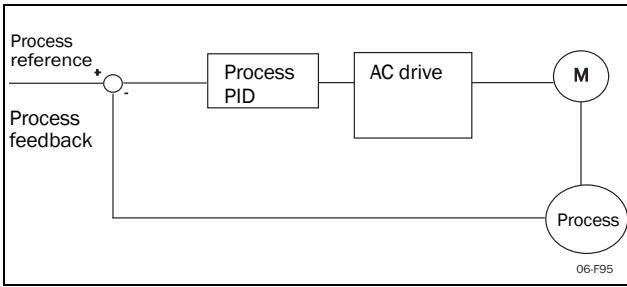

Fig. 79 Closed loop PID control

PID I Time [384]

Setting the integration time for the PID controller.

| | |
|-----------------------|------------|
| 384 PID I Time | |
| StpA 1.00s | |
| Default: | 1.00 s |
| Range: | 0.01-300 s |

Communication information

| | |
|----------------------------------|----------------|
| Modbus Instance no/DeviceNet no: | 43157 |
| Profibus slot/index | 169/61 |
| Fieldbus format | Long, 1=0.01 s |
| Modbus format | Elnt |

Process PID D Time [385]

Setting the differentiation time for the PID controller.

| | |
|-----------------------|-----------|
| 385 PID D Time | |
| StpA 0.00s | |
| Default: | 0.00 s |
| Range: | 0.00-30 s |

Communication information

| | |
|----------------------------------|----------------|
| Modbus Instance no/DeviceNet no: | 43158 |
| Profibus slot/index | 169/62 |
| Fieldbus format | Long, 1=0.01 s |
| Modbus format | Elnt |

PID sleep functionality

This function is controlled via a wait delay and a separate wake-up margin condition. With this function it is possible to put the AC drive in “sleep mode” when the process value is at its set point and the motor is running at minimum speed for the length of the time set in [386]. By going into sleep mode, the by the application consumed energy is reduced to a minimum. When the process feedback value goes below the set margin on the process reference as set in [387], the AC drive will wake up automatically and normal PID operation continues, see examples.

PID sleep when less than minimum speed [386]

If the PID output is equal to or less than minimum speed for given delay time, the AC drive will go to sleep.

| | |
|--------------------------|-------------------|
| 386 PID<MinSpd | |
| StpA Off | |
| Default: | Off |
| Range: | Off, 0.01 -3600 s |

Communication information

| | |
|----------------------------------|----------------|
| Modbus Instance no/DeviceNet no: | 43371 |
| Profibus slot/index | 170/20 |
| Fieldbus format | Long, 1=0.01 s |
| Modbus format | Elnt |

NOTE: Menu [386] has higher priority than menu [342].

PID Activation Margin [387]

The PID activation (wake-up) margin is related to the process reference and sets the limit when the AC drive should wake-up/start again.

| | |
|-------------------------|--------------------------|
| 387 PID Act Marg | |
| StpA 0rpm | |
| Default: | 0 |
| Range: | 0 -10000 in Process unit |

Communication information

| | |
|----------------------------------|--------|
| Modbus Instance no/DeviceNet no: | 43372 |
| Profibus slot/index | 170/21 |
| Fieldbus format | Long |
| Modbus format | Elnt |

NOTE: The margin is always a positive value.

Example 1 PID control = normal (flow or pressure control)

- [321] = F (AnIn)
- [322] = Bar
- [310] = 20 Bar
- [342] = 2 s (inactive since [386] is activated and have higher priority)
- [381]= On
- [386] = 10 s
- [387] = 1 Bar

The AC drive will stop/sleep when the speed (PID output) is below or equal to Min Speed for 10 seconds. The AC drive will activate/wake up when the “Process value” goes below the PID Activation Margin which is related to the process reference, i.e. goes below (20-1) Bar. See Fig. 80.

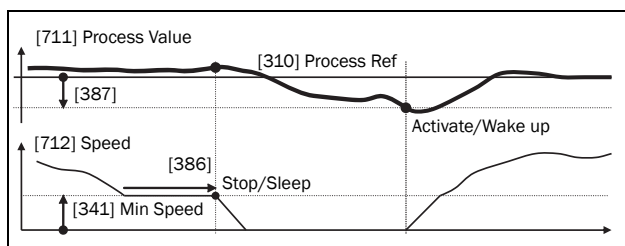

Fig. 80 PID Stop/sleep with normal PID

Example 2 PID control = inverted (tank level control)

- [321] = F (AnIn)
- [322] = m
- [310] = 7 m
- [342] = 2 s (inactive since [386] is activated and have higher priority)
- [381]= Inverted
- [386] = 30 s
- [387] = 1 m

The AC drive will stop/sleep when the speed (PID output) is below or equal to Min Speed for 30 seconds. The AC drive will activate/wake up when the “Process value” goes above the PID Activation Margin which is related to the process reference, i.e. goes above (7+1) m. See Fig. 81.

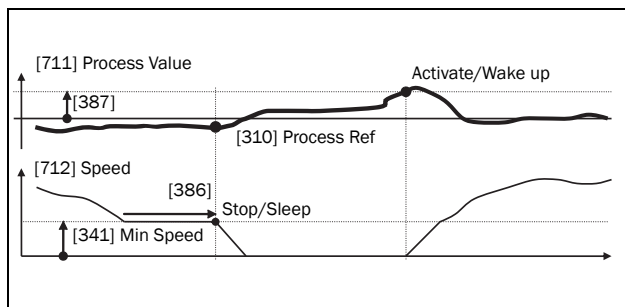

Fig. 81 PID Stop/sleep with inverted PID

PID Steady State Test [388]

In application situations where the feedback can become independent of the motor speed, this PID Steady Test function can be used to overrule the PID operation and force the AC drive to go in sleep mode i.e. the AC drive automatically reduces the output speed while at the same time ensures the process value.

Example: pressure controlled pump systems with low/no flow operation and where the process pressure has become independent of the pump speed, e.g. due to slowly closed valves. By going into Sleep mode, heating of the pump and motor will be avoided and no energy is spilled.

PID Steady state test delay.

NOTE: It is important that the system has reached a stable situation before the Steady State Test is initiated.

| | |
|-------------------------|------------------|
| 388 PID Stdy Tst | |
| Stp ^A Off | |
| Default: | Off |
| Range: | Off, 0.01–3600 s |

Communication information

| | |
|----------------------------------|----------------|
| Modbus Instance no/DeviceNet no: | 43373 |
| Profibus slot/index | 170/22 |
| Fieldbus format | Long, 1=0.01 s |
| Modbus format | EInt |

PID Steady State Margin [389]

PID steady state margin defines a margin band around the reference that defines “steady state operation”. During the steady state test the PID operation is overruled and the AC drive is decreasing the speed as long as the PID error is within the steady state margin. If the PID error goes outside the steady state margin the test failed and normal PID operation continues, see example.

| | |
|-------------------------|-------------------------|
| 389 PID Stdy Mar | |
| Stp ^A 0 | |
| Default: | 0 |
| Range: | 0–10000 in process unit |

Communication information

| | |
|----------------------------------|----------------|
| Modbus Instance no/DeviceNet no: | 43374 |
| Profibus slot/index | 170/23 |
| Fieldbus format | Long, 1=0.01 s |
| Modbus format | EInt |

Example: The PID Steady Test starts when the process value [711] is within the margin and Steady State Test Wait Delay has expired. The PID output will decrease speed with a step value which corresponds to the margin as long as the Process value [711] stays within steady state margin. When Min Speed [341] is reached the steady state test was successful and stop/sleep is commanded if PID sleep function [386] and [387] is

activated. If the Process value [711] goes outside the set steady state margins then the test failed and normal PID operation will continue, see Fig. 82

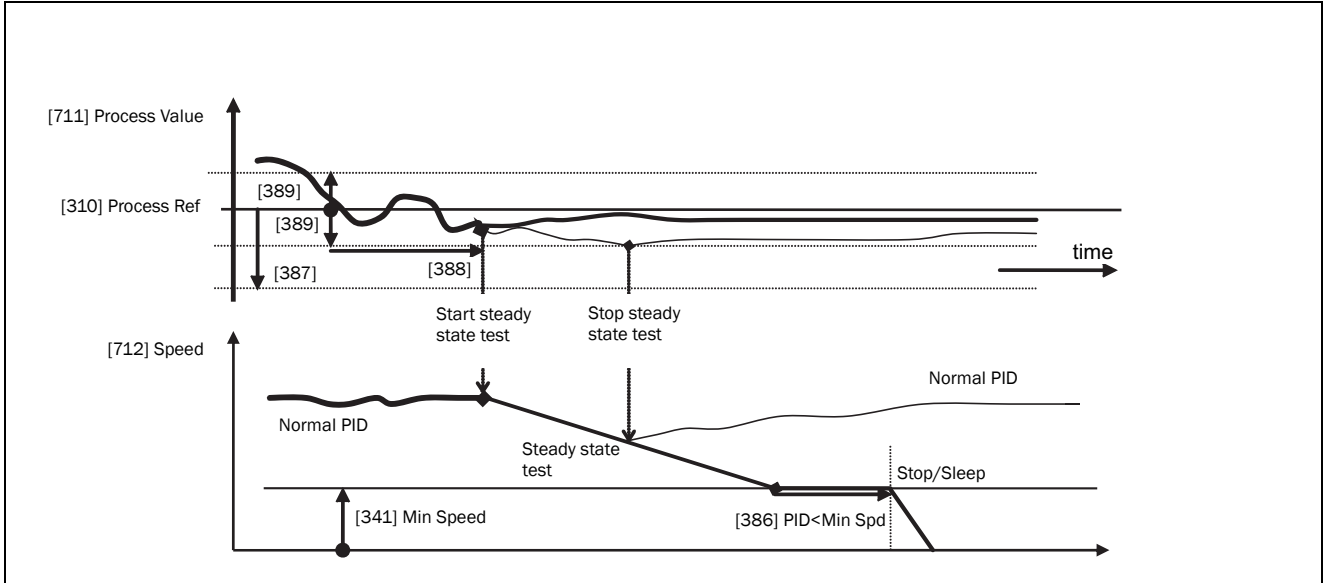

Fig. 82 Steady state test

11.3.10 Pump/Fan Control [390]

The Pump Control functions are in menu [390]. The function is used to control a number of drives (pumps, fans, etc.) of which one is always driven by the AC drive.

Pump enable [391]

This function will enable the pump control to set all relevant pump control functions.

| | |
|--|--|
| 391 Pump enable Stp _A Off | |
| Default: | Off |
| Off | 0 Pump control is switched off. |
| On | 1 Pump control is on: - Pump control parameters [392] to [39G] appear and are activated according to default settings. - View functions [39H] to [39M] are added in the menu structure. |

Communication information

| | |
|----------------------------------|--------|
| Modbus Instance no/DeviceNet no: | 43161 |
| Profibus slot/index | 169/65 |
| Fieldbus format | UInt |
| Modbus format | UInt |

Number of Drives [392]

Sets the total number of drives which are used, including the Master AC drive. The setting here depends on the parameter Select Drive [393]. After the number of drives is chosen it is important to set the relays for the pump control. If the digital inputs are also used for status feedback, these must be set for the pump control according to; Pump 1 OK – Pump6 OK in menu [520].

| | |
|---|--|
| 392 No of Drives Stp _A 1 | |
| Default: | 1 |
| 1-3 | Number of drives if I/O Board is not used. |
| 1-6 | Number of drives if 'Alternating MASTER' is used, see Select Drive [393]. (I/O Board is used.) |
| 1-7 | Number of drives if 'Fixed MASTER' is used, see Select Drive [393]. (I/O Board is used.) |

NOTE: Used relays must be defined as Slave Pump or Master Pump. Used digital inputs must be defined as Pump Feedback.

Communication information

| | |
|----------------------------------|--------|
| Modbus Instance no/DeviceNet no: | 43162 |
| Profibus slot/index | 169/66 |
| Fieldbus format | UInt |
| Modbus format | UInt |

Select Drive [393]

Sets the main operation of the pump system. 'Sequence' and 'Runtime' are Fixed MASTER operation. 'All' means Alternating MASTER operation.

| | |
|--|---|
| 393 Select Drive Stp _A Sequence | |
| Default: | Sequence |
| Sequence | 0 Fixed MASTER operation: - The additional drives will be selected in sequence, i.e. first pump 1 then pump 2 etc. - A maximum of 7 drives can be used. |
| Run Time | 1 Fixed MASTER operation: - The additional drives will be selected depending on the Run Time. So the drive with the lowest Run Time will be selected first. The Run Time is monitored in menus [39H] to [39M] in sequence. For each drive the Run Time can be reset. - When drives are stopped, the drive with the longest Run Time will be stopped first. - Maximum 7 drives can be used. |
| All | 2 Alternating MASTER operation: - When the drive is powered up, one drive is selected as the Master drive. The selection criteria depends on the Change Condition [394]. The drive will be selected according to the Run Time. So the drive with the lowest Run Time will be selected first. The Run Time is monitored in menus [39H] to [39M] in sequence. For each drive the Run Time can be reset. - A maximum of 6 drives can be used. |

Communication information

| | |
|----------------------------------|--------|
| Modbus Instance no/DeviceNet no: | 43163 |
| Profibus slot/index | 169/67 |
| Fieldbus format | UInt |
| Modbus format | UInt |

NOTE: This menu will NOT be active if less than 3 drives are selected.

Change Condition [394]

This parameter determines the criteria for changing the master. This menu only appears if Alternating MASTER operation is selected. The elapsed run time of each drive is monitored. The elapsed run time always determines which drive will be the 'new' master drive.

This function is only active if the parameter Select Drive [393]=All.

| | | 394 Change Cond Stp A Both |
|----------|---|--|
| Default: | | Both |
| Stop | 0 | The Runtime of the master drive determines when a master drive has to be changed. The change will only take place after a: - Power Up - Stop - Standby condition - Trip condition. |
| Timer | 1 | The master drive will be changed if the timer setting in Change Timer [395] has elapsed. The change will take place immediately. So during operation the additional pumps will be stopped temporarily, the 'new' master will be selected according to the Run Time and the additional pumps will be started again. It is possible to leave 2 pumps running during the change operation. This can be set with Drives on Change [396]. |
| Both | 2 | The master drive will be changed if the timer setting in Change Timer [395] has elapsed. The 'new' master will be selected according to the elapsed Run Time. The change will only take place after a: - Power Up - Stop - Standby condition. - Trip condition. |

Communication information

| | |
|----------------------------------|--------|
| Modbus Instance no/DeviceNet no: | 43164 |
| Profibus slot/index | 169/68 |
| Fieldbus format | UInt |
| Modbus format | UInt |

NOTE: If the Status feedback inputs (DigIn 9 to DigIn 14) are used, the master drive will be changed immediately if the feedback generates an 'Error'.

Change Timer [395]

When the time set here is elapsed, the master drive will be changed. This function is only active if Select Drive [393]=All and Change Cond [394]= Timer/ Both.

| | | 395 Change Timer Stp A 50h |
|----------|--|--|
| Default: | | 50 h |
| Range: | | 1-3000 h |

Communication information

| | |
|----------------------------------|-------------|
| Modbus Instance no/DeviceNet no: | 43165 |
| Profibus slot/index | 169/69 |
| Fieldbus format | UInt, 1=1 h |
| Modbus format | UInt, 1=1 h |

Drives on Change [396]

If a master drive is changed according to the timer function (Change Condition=Timer/Both [394]), it is possible to leave additional pumps running during the change operation. With this function the change operation will be as smooth as possible. The maximum number to be programmed in this menu depends on the number of additional drives.

Example:

If the number of drives is set to 6, the maximum value will be 4. This function is only active if Select Drive [393]=All.

| | | 396 Drives on Ch Stp A 0 |
|----------|--|--|
| Default: | | 0 |
| Range: | | 0 to (the number of drives - 2) |

Communication information

| | |
|----------------------------------|--------|
| Modbus Instance no/DeviceNet no: | 43166 |
| Profibus slot/index | 169/70 |
| Fieldbus format | UInt |
| Modbus format | UInt |

Upper Band [397]

If the speed of the master drive comes into the upper band, an additional drive will be added after a delay time that is set in start delay [399].

| | |
|-------------------------|--|
| 397 Upper Band | |
| Stp A 10% | |
| Default: | 10% |
| Range: | 0-100% of total min speed to max speed |

Communication information

| | |
|----------------------------------|------------|
| Modbus Instance no/DeviceNet no: | 43167 |
| Profibus slot/index | 169/71 |
| Fieldbus format | Long, 1=1% |
| Modbus format | EInt |

Example:

Max Speed = 1500 rpm
 Min Speed = 300 rpm
 Upper Band = 10%

Start delay will be activated:

Range = Max Speed to Min Speed = 1500-300 = 1200 rpm

10% of 1200 rpm = 120 rpm

Start level = 1500-120 = 1380 rpm

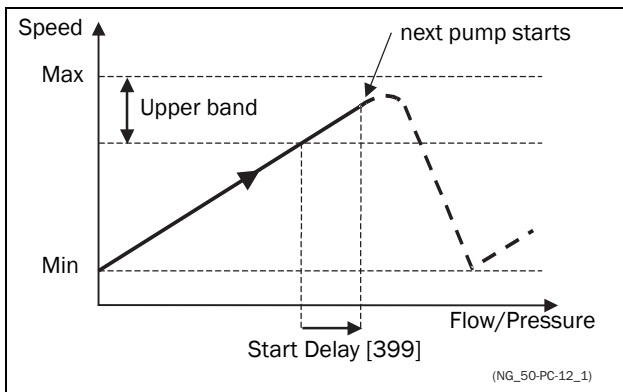

Fig. 83 Upper band

Lower Band [398]

If the speed of the master drive comes into the lower band an additional drive will be stopped after a delay time. This delay time is set in the parameter Stop Delay [39A].

| | |
|-------------------------|--|
| 398 Lower Band | |
| Stp A 10% | |
| Default: | 10% |
| Range: | 0-100% of total min speed to max speed |

Communication information

| | |
|----------------------------------|------------|
| Modbus Instance no/DeviceNet no: | 43168 |
| Profibus slot/index | 169/72 |
| Fieldbus format | Long, 1=1% |
| Modbus format | EInt |

Example:

Max Speed = 1500 rpm
 Min Speed = 300 rpm
 Lower Band = 10%

Stop delay will be activated:

Range = Max Speed - Min Speed = 1500-300 = 1200 rpm

10% of 1200 rpm = 120 rpm

Start level = 300 + 120 = 420 rpm

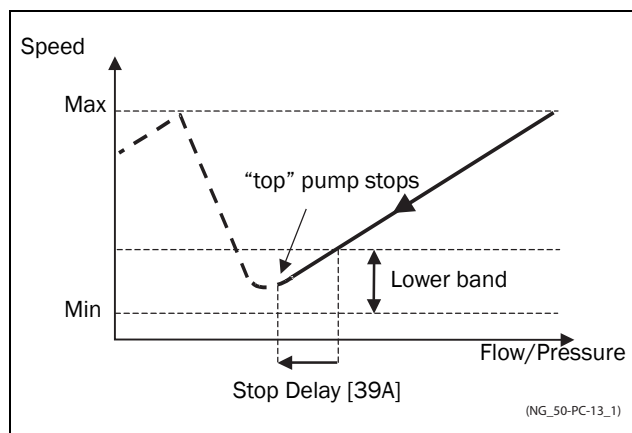

Fig. 84 Lower band

Start Delay [399]

This delay time must have elapsed before the next pump is started. A delay time prevents the nervous switching of pumps.

| | |
|------------------------|---------|
| 399 Start Delay | |
| Stp A 0s | |
| Default: | 0 s |
| Range: | 0-999 s |

Communication information

| | |
|----------------------------------|------------|
| Modbus Instance no/DeviceNet no: | 43169 |
| Profibus slot/index | 169/73 |
| Fieldbus format | Long, 1=1s |
| Modbus format | EInt |

Stop Delay [39A]

This delay time must have elapsed before the 'top' pump is stopped. A delay time prevents the nervous switching of pumps.

| | |
|--|---------|
| 39A Stop Delay Stp A 0s | |
| Default: | 0 s |
| Range: | 0-999 s |

Communication information

| | |
|----------------------------------|-------------|
| Modbus Instance no/DeviceNet no: | 43170 |
| Profibus slot/index | 169/74 |
| Fieldbus format | Long, 1=1 s |
| Modbus format | Elnt |

Upper Band Limit [39B]

If the speed of the pump reaches the upper band limit, the next pump is started immediately without delay. If a start delay is used this delay will be ignored. Range is between 0%, equalling max speed, and the set percentage for the UpperBand [397].

| | |
|--|---|
| 39B Upp Band Lim Stp A 0% | |
| Default: | 0% |
| Range: | 0 to Upper Band level. 0% (=max speed) means that the Limit function is switched off. |

Communication information

| | |
|----------------------------------|------------|
| Modbus Instance no/DeviceNet no: | 43171 |
| Profibus slot/index | 169/75 |
| Fieldbus format | Long, 1=1% |
| Modbus format | Elnt |

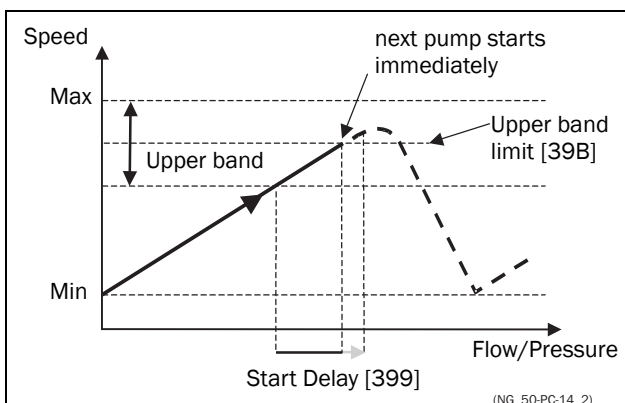

Fig. 85 Upper band limit

Lower Band Limit [39C]

If the speed of the pump reaches the lower band limit, the 'top' pump is stopped immediately without delay. If a stop delay is used this delay will be ignored. Range is from 0%, equalling min speed, to the set percentage for the Lower Band [398].

| | |
|--|---|
| 39C Low Band Lim Stp A 0% | |
| Default: | 0% |
| Range: | 0 to Lower Band level. 0% (=min speed) means that the Limit function is switched off. |

Communication information

| | |
|----------------------------------|------------|
| Modbus Instance no/DeviceNet no: | 43172 |
| Profibus slot/index | 169/76 |
| Fieldbus format | Long, 1=1% |
| Modbus format | Elnt |

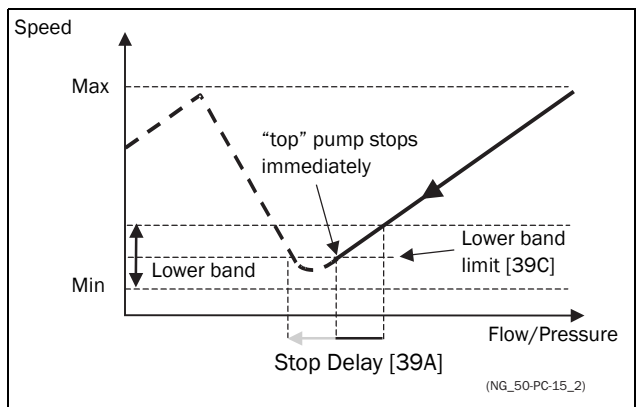

Fig. 86 Lower band limit

Settle Time Start [39D]

The settle start allows the process to settle after a pump is switched on before the pump control continues. If an additional pump is started D.O.L. (Direct On Line) or Y/ Δ, the flow or pressure can still fluctuate due to the 'rough' start/stop method. This could cause unnecessary starting and stopping of additional pumps.

During the Settle start:

- PID controller is off.
- The speed is kept at a fixed level after adding a pump.

| | |
|--|---------|
| 39D Settle Start Stp A 0s | |
| Default: | 0 s |
| Range: | 0-999 s |

Communication information

| | |
|----------------------------------|-------------|
| Modbus Instance no/DeviceNet no: | 43173 |
| Profibus slot/index | 169/77 |
| Fieldbus format | Long, 1=1 s |
| Modbus format | Elnt |

Transition Speed Start [39E]

The transition speed start is used to minimize a flow/pressure overshoot when adding another pump. When an additional pump needs to be switched on, the master pump will slow down to the set transition speed start value, before the additional pump is started. The setting depends on the dynamics of both the master drive and the additional drives.

The transition speed is best set by trial and error.

In general:

- If the additional pump has 'slow' start/stop dynamics, then a higher transition speed should be used.
- If the additional pump has 'fast' start/stop dynamics, then a lower transition speed should be used.

| | |
|--|--|
| 39E TransS Start | |
| Stp A 60% | |
| Default: | 60% |
| Range: | 0-100% of total min speed to max speed |

Communication information

| | |
|----------------------------------|------------|
| Modbus Instance no/DeviceNet no: | 43174 |
| Profibus slot/index | 169/78 |
| Fieldbus format | Long, 1=1% |
| Modbus format | Elnt |

Example

Max Speed = 1500 rpm
 Min Speed = 200 rpm
 TransS Start = 60%

When an additional pump is needed, the speed will be controlled down to min speed + (60% x (1500 rpm - 200 rpm)) = 200 rpm + 780 rpm = 980 rpm. When this speed is reached, the additional pump with the lowest run time hours will be switched on.

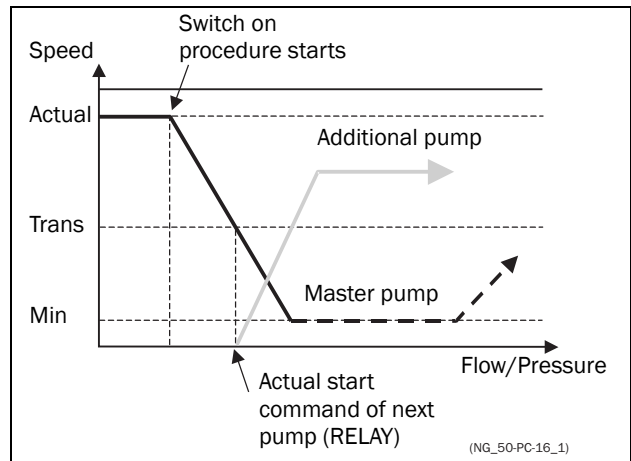

Fig. 87 Transition speed start

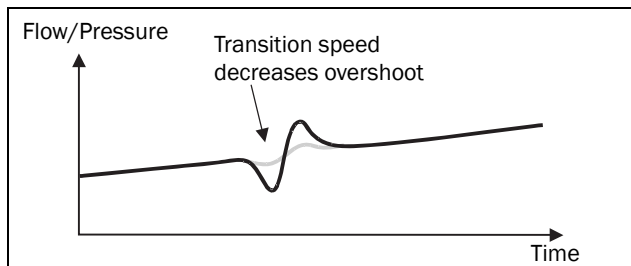

Fig. 88 Effect of transition speed

Settle Time Stop [39F]

The settle stop allows the process to settle after a pump is switched off before the pump control continues. If an additional pump is stopped D.O.L. (Direct On Line) or Y/ Δ, the flow or pressure can still fluctuate due to the 'rough' start/stop method. This could cause unnecessary starting and stopping of additional pumps.

During the Settle stop:

- PID controller is off.
- the speed is kept at a fixed level after stopping a pump

| | |
|---|---------|
| 39F Settle Stop | |
| Stp A 0s | |
| Default: | 0 s |
| Range: | 0-999 s |

Communication information

| | |
|----------------------------------|-------------|
| Modbus Instance no/DeviceNet no: | 43175 |
| Profibus slot/index | 169/79 |
| Fieldbus format | Long, 1=1 s |
| Modbus format | Elnt |

Transition Speed Stop [39G]

The transition speed stop is used to minimize a flow/pressure overshoot when shutting down an additional pump. The setting depends on the dynamics of both the master drive and the additional drives.

In general:

- If the additional pump has 'slow' start/stop dynamics, then a higher transition speed should be used.
- If the additional pump has 'fast' start/stop dynamics, then a lower transition speed should be used.

| | |
|---|--|
| 39G TransS Stop Stp A 60% | |
| Default: | 60% |
| Range: | 0-100% of total min speed to max speed |

Communication information

| | |
|----------------------------------|------------|
| Modbus Instance no/DeviceNet no: | 43176 |
| Profibus slot/index | 169/80 |
| Fieldbus format | Long, 1=1% |
| Modbus format | Elnt |

Example

Max Speed = 1500 rpm

Min Speed = 200 rpm

TransS Start = 60%

When less additional pumps are needed, the speed will be controlled up to min speed + (60% x (1500 rpm - 200 rpm)) = 200 rpm + 780 rpm = 980 rpm. When this speed is reached, the additional pump with the highest run time hours will be switched off.

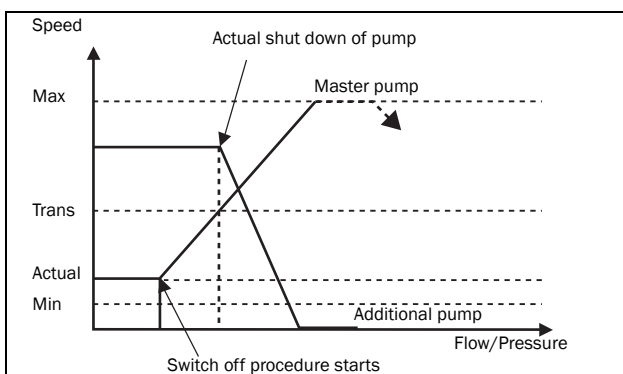

Fig. 89 Transition speed stop

Run Times 1-6 [39H] to [39M]

| | |
|---|---------------------------------|
| 39H Run Time 1 Stp A h:mm:ss | |
| Unit: | h:mm:ss (hours:minutes:seconds) |
| Range: | 0:00:00-262143:59:59 |

Communication information

| | |
|----------------------------------|---|
| Modbus Instance no/DeviceNet no: | 31051 : 31052 : 31053(hr:min:sec) 31054 : 31055: 31056(hr:min:sec) 31057 : 31058: 31059(hr:min:sec) 31060 : 31061: 31062(hr:min:sec) 31063 : 31064: 31065(hr:min:sec) 31066 : 31067: 31068(hr:min:sec) |
| Profibus slot/index | 121/195, 121/196, 121/197, 121/198, 121/199, 121/200, 121/201, 121/202, 121/203, 121/204, 121/205, 121/206, 121/207, 121/208, 121/209, 121/210, 121/211, 121/212 |
| Fieldbus format | Long, 1=1h/m/s |
| Modbus format | Elnt, 1=1h/m/s |

Reset Run Times 1-6 [39H1] to [39M1]

| | |
|--|----|
| 39H1 Rst Run Tm1 Stp A No | |
| Default: | No |
| No | 0 |
| Yes | 1 |

Communication information

| | |
|----------------------------------|-----------------|
| Modbus Instance no/DeviceNet no: | 38-43, pump 1-6 |
| Profibus slot/index | 0/37-0/42 |
| Fieldbus format | UInt |
| Modbus format | UInt |

Pump Status [39N]

| |
|------------------------|
| 39N Pump 123456 |
| StpA OCD |

| Indication | Description |
|------------|--|
| C | Control, master pump, only when alternating master is used |
| D | Direct control |
| O | Pump is off |
| E | Pump error |

Number backup/reserve [39P]

Sets the number of pumps used for backup/reserve which in normal conditions can not be selected. This function can be used for increasing redundancy in the pump system by having pumps in reserve that can be activated when some pumps indicate fault or are shut off for maintenance.

| |
|-------------------------|
| 39P No of Backup |
| StpA 0 |
| Default: 0 |
| Range: 0-3 |

Communication information

| | |
|----------------------------------|--------|
| Modbus Instance no/DeviceNet no: | 43177 |
| Profibus slot/index | 169/81 |
| Fieldbus format | UInt |
| Modbus format | UInt |

11.3.11 Crane Option [3A0]

Settings for the optional Crane board (Crane Remote Input/Output card). See also the Crane option instruction manual.

NOTE: This menu is only visible if the crane board is connected to the AC drive.

Crane enable [3A1]

When the crane option board is connected, it is possible to (de)activate the crane option board inputs.

NOTE: Deviation function is active even if [3A1]=off.

| |
|--|
| 3A1 Crane enable |
| StpA On |
| Default: Off |
| Off 0 Crane option board deactivated |
| On 1 Crane option board activated |

Communication information

| | |
|----------------------------------|--------|
| Modbus Instance no/DeviceNet no: | 43181 |
| Profibus slot/index | 169/85 |
| Fieldbus format | UInt |
| Modbus format | UInt |

Control [3A2]

To select the type of crane joystick control.

| |
|--|
| 3A2 Control |
| StpA 4-Speeds |
| Default: 4-Speeds |
| 4-Speeds 0 4-Speed joystick |
| 3-Pos 1 3-Position switch |
| Analogue 2 Analogue joystick |

Communication information

| | |
|----------------------------------|--------|
| Modbus Instance no/DeviceNet no: | 43182 |
| Profibus slot/index | 169/86 |
| Fieldbus format | UInt |
| Modbus format | UInt |

Crane Relay CR1 [3A3]

Crane Relay CR1 on the Crane option board is fixed to the No Trip function.

| | |
|---|------------------|
| 3A3 Crane Relay1 Stp _A No Trip | |
| Default: | No Trip |
| Selections | Fixed to No Trip |

Communication information

| | |
|----------------------------------|--------|
| Modbus Instance no/DeviceNet no: | 43183 |
| Profibus slot/index | 169/87 |
| Fieldbus format | UInt |
| Modbus format | UInt |

Crane Relay CR2 [3A4]

To select the function of Crane Relay CR2 on the Crane option board. Same selections as for the relays on the control board.

| | |
|---|--|
| 3A4 Crane Relay2 Stp _A Brake | |
| Default: | Brake |
| Selections | Same selections as for the relays on the control board |

Communication information

| | |
|----------------------------------|--------|
| Modbus Instance no/DeviceNet no: | 43184 |
| Profibus slot/index | 169/88 |
| Fieldbus format | UInt |
| Modbus format | UInt |

Pre Limit Switch Speed [3A5]

To set the speed used when Pre-Limit Switch on the Crane option board is active.

| | |
|--|--------------------------|
| 3A5 PreLimSwSpd Stp _A rpm | |
| Default: | 0 rpm |
| Range: | 0 - 4 x Motor Sync speed |

Communication information

| | |
|----------------------------------|--------------|
| Modbus Instance no/DeviceNet no: | 43185 |
| Profibus slot/index | 169/89 |
| Fieldbus format | Int, 1=1 rpm |
| Modbus format | Int, 1=1 rpm |

Crawl speed H/R [3A6]

To set the speed used when crawling (min. speed) during a hoisting operation. Activated with input A1, Crawl H/R=Start in positive speed direction

| | |
|---|--------------------|
| 3A6 CrawlSpd H/R Stp _A rpm | |
| Default: | 0 |
| Range: | 0 - 4 x Sync speed |

Communication information

| | |
|----------------------------------|--------------|
| Modbus Instance no/DeviceNet no: | 43189 |
| Profibus slot/index | 169/93 |
| Fieldbus format | Int, 1=1 rpm |
| Modbus format | Int, 1=1 rpm |

Crawl speed L/L [3A7]

To set the speed used when crawling (min. speed) during lowering operation. Activated with input A2, Crawl L/L=Start in negative speed direction.

| | |
|---|--------------------|
| 3A7 CrawlSpd L/L Stp _A rpm | |
| Default: | 0 |
| Range: | 0 - 4 x Sync speed |

Communication information

| | |
|----------------------------------|--------------|
| Modbus Instance no/DeviceNet no: | 43190 |
| Profibus slot/index | 169/94 |
| Fieldbus format | Int, 1=1 rpm |
| Modbus format | Int, 1=1 rpm |

Speed 2 [3A8]

To set the speed used when the input B1, Speed 2 on the Crane option board is active.

| | |
|--|--------------------|
| 3A8 Speed 2 Stp _A rpm | |
| Default: | 0 |
| Range: | 0 – 4 x Sync speed |

Communication information

| | |
|----------------------------------|--------------|
| Modbus Instance no/DeviceNet no: | 43186 |
| Profibus slot/index | 169/90 |
| Fieldbus format | Int, 1=1 rpm |
| Modbus format | Int, 1=1 rpm |

Speed 3 [3A9]

To set the speed used when the input B2, Speed 3 on the Crane option board is active.

| | |
|--|--------------------------|
| 3A9 Speed 3 Stp _A rpm | |
| Default: | 0 |
| Range: | 0 – 4 x Motor Sync speed |

Communication information

| | |
|----------------------------------|--------|
| Modbus Instance no/DeviceNet no: | 43187 |
| Profibus slot/index | 169/91 |
| Fieldbus format | Int |
| Modbus format | Int |

Speed 4 [3AA]

To set the speed used when the input B3, Speed 4 on the Crane option board is active.

| | |
|--|--------------------------|
| 3AA Speed 4 Stp _A rpm | |
| Default: | 0 |
| Range: | 0 – 4 x Motor Sync speed |

Communication information

| | |
|----------------------------------|--------|
| Modbus Instance no/DeviceNet no: | 43188 |
| Profibus slot/index | 169/92 |
| Fieldbus format | Int |
| Modbus format | Int |

Deviation Band width [3AB]

To define the speed deviation window within which the AC drive is in control of the motor.

| | |
|--|--------------------|
| 3AB Dev Bandwidth Stp _A rpm | |
| Default: | 0 |
| Range: | 0 – 4 x Sync speed |

Communication information

| | |
|----------------------------------|--------------|
| Modbus Instance no/DeviceNet no: | 43191 |
| Profibus slot/index | 169/95 |
| Fieldbus format | Int, 1=1 rpm |
| Modbus format | Int, 1=1 rpm |

Deviation Time [3AC]

To set the time during which the deviation condition must be active, before the inverter trips.

| | |
|--|------------|
| 3AC Dev. Time Stp _A s | |
| Default: | 0.10 s |
| Range: | 0.05 – 1 s |

Communication information

| | |
|----------------------------------|-----------------|
| Modbus Instance no/DeviceNet no: | 43192 |
| Profibus slot/index | 169/96 |
| Fieldbus format | Long, 1=0.001 s |
| Modbus format | EInt |

LAFS Load [3AD]

To set the load below which the VFB/V33 goes into load dependent field weakening operation.

| | | |
|--|-------|-----------|
| 3AD LAFS Load Stp _A Off | | |
| Default: | Off | |
| Off | 0 | Off |
| 1–100 | 1–100 | 1% – 100% |

Communication information

| | |
|----------------------------------|------------|
| Modbus Instance no/DeviceNet no: | 43193 |
| Profibus slot/index | 169/97 |
| Fieldbus format | Long, 1=1% |
| Modbus format | EInt |

When set to OFF, the load dependent field weakening function is switched off.

CRIO N input function [3AG]

Sets the function of CRIO/Crane I/O interface N(Null) input.

| 3AG Crane N Func Stp _A Zero Pos | | |
|---|---|---|
| Default: | | Zero Pos |
| Off | 0 | N input not used |
| Zero Pos | 1 | N input used for joystick zero position indication. |
| Brk Ackn | 2 | N input used for Brake Acknowledge. see page 90. |

Communication information

| | |
|----------------------------------|--------|
| Modbus Instance no/DeviceNet no: | 43194 |
| Profibus slot/index | 169/98 |
| Fieldbus format | UInt |
| Modbus format | UInt |

Note: Brake Acknowledge via Crane I/O has priority (and overrules) Brake acknowledge via control board I/O ([521 DigIn1] - [528 Dig In8]).

11.4 Load Monitor and Process Protection [400]

11.4.1 Load Monitor [410]

The monitor functions enable the AC drive to be used as a load monitor. Load monitors are used to protect machines and processes against mechanical overload and underload, e.g. a conveyer belt or screw conveyer jamming, belt failure on a fan and a pump dry running. See explanation in section 7.5, page 40.

Alarm Select [411]

Selects the types of alarms that are active.

| 411 Alarm Select Stp _A Off | | |
|--|---|---|
| Default: | | Off |
| Off | 0 | No alarm functions active. |
| Min | 1 | Min Alarm active. The alarm output functions as an underload alarm. |
| Max | 2 | Max Alarm active. The alarm output functions as an overload alarm. |
| Max+Min | 3 | Both Max and Min alarm are active. The alarm outputs function as overload and underload alarms. |

Communication information

| | |
|----------------------------------|---------|
| Modbus Instance no/DeviceNet no: | 43321 |
| Profibus slot/index | 169/225 |
| Fieldbus format | UInt |
| Modbus format | UInt |

Alarm Trip [412]

Selects which alarm must cause a trip to the AC drive.

| 412 Alarm trip Stp _A Off | | |
|--|--|-----------------------|
| Default: | | Off |
| Selection: | | Same as in menu [411] |

Communication information

| | |
|----------------------------------|---------|
| Modbus Instance no/DeviceNet no: | 43322 |
| Profibus slot/index | 169/226 |
| Fieldbus format | UInt |
| Modbus format | UInt |

Ramp Alarm [413]

This function inhibits the (pre) alarm signals during acceleration/deceleration of the motor to avoid false alarms.

| | | |
|-------------------------|-----|--|
| 413 Ramp Alarm | | |
| Stp A Off | | |
| Default: | Off | |
| Off | 0 | (Pre) alarms are inhibited during acceleration/deceleration. |
| On | 1 | (Pre) alarms active during acceleration/deceleration. |

Communication information

| | |
|----------------------------------|---------|
| Modbus Instance no/DeviceNet no: | 43323 |
| Profibus slot/index | 169/227 |
| Fieldbus format | UInt |
| Modbus format | UInt |

Alarm Start Delay [414]

This parameter is used if, for example, you want to override an alarm during the start-up procedure.

Sets the delay time after a run command, after which the alarm may be given.

- If Ramp Alarm=On. The start delay begins after a RUN command.
- If Ramp Alarm=Off. The start delay begins after the acceleration ramp.

| | | |
|------------------------|----------|--|
| 414 Start Delay | | |
| Stp A 2s | | |
| Default: | 2 s | |
| Range: | 0-3600 s | |

Communication information

| | |
|----------------------------------|-------------|
| Modbus Instance no/DeviceNet no: | 43324 |
| Profibus slot/index | 169/228 |
| Fieldbus format | Long, 1=1 s |
| Modbus format | EInt |

Load Type [415]

In this menu you select monitor type according to the load characteristic of your application. By selecting the required monitor type, the overload and underload alarm function can be optimized according to the load characteristic.

When the application has a constant load over the whole speed range, i.e. extruder or screw compressor, the load type can be set to basic. This type uses a single value as a reference for the nominal load. This value is used for the complete speed range of the AC drive. The value can be set or automatically measured. See Autoselect Alarm [41A] and Normal Load [41B] about setting the nominal load reference.

The load curve mode uses an interpolated curve with 9 load values at 8 equal speed intervals. This curve is populated by a test run with a real load. This can be used with any smooth load curve including constant load.

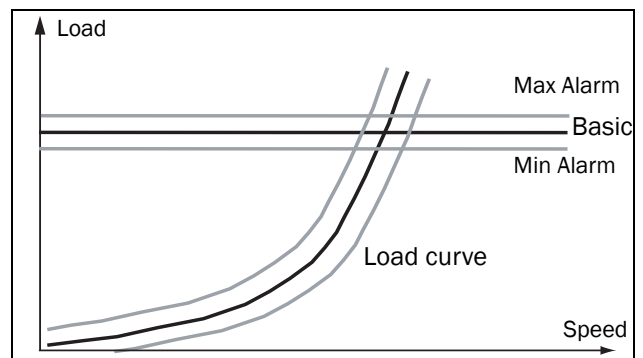

Fig. 90

| | | |
|---------------------------|-------|--|
| 415 Load Type | | |
| Stp A Basic | | |
| Default: | Basic | |
| Basic | 0 | Uses a fixed maximum and minimum load level over the full speed range. Can be used in situations where the torque is independent of the speed. |
| Load Curve | 1 | Uses the measured actual load characteristic of the process over the speed range. |

Communication information

| | |
|----------------------------------|---------|
| Modbus Instance no/DeviceNet no: | 43325 |
| Profibus slot/index | 169/229 |
| Fieldbus format | UInt |
| Modbus format | UInt |

Max Alarm [416]

Max Alarm Margin [4161]

With load type Basic, [415], used the Max Alarm Margin sets the band above the Normal Load, [41B], menu that does not generate an alarm. With load type Load Curve, [415], used the Max Alarm Margin sets the band above the Load Curve, [41C], that does not generate an alarm. The Max Alarm Margin is a percentage of nominal motor torque.

| | |
|--|--------|
| 4161 MaxAlarmMar Stp A 15% | |
| Default: | 15% |
| Range: | 0-400% |

Communication information

| | |
|----------------------------------|------------|
| Modbus Instance no/DeviceNet no: | 43326 |
| Profibus slot/index | 169/230 |
| Fieldbus format | Long, 1=1% |
| Modbus format | EInt |

Max Alarm delay [4162]

Sets the delay time between the first occurrence of max alarm condition and after when the alarm is given.

| | |
|---|--------|
| 4162 MaxAlarmDel Stp A 0.1s | |
| Default: | 0.1 s |
| Range: | 0-90 s |

Communication information

| | |
|----------------------------------|---------------|
| Modbus Instance no/DeviceNet no: | 43330 |
| Profibus slot/index | 169/234 |
| Fieldbus format | Long, 1=0.1 s |
| Modbus format | EInt |

Max Pre Alarm [417]

Max Pre AlarmMargin [4171]

With load type Basic, [415], used the Max Pre-Alarm Margin sets the band above the Normal Load, [41B], menu that does not generate a pre-alarm. With load type Load Curve, [415], used the Max Pre-Alarm Margin sets the band above the Load Curve, [41C], that does not generate a pre-alarm. The Max Pre-Alarm Margin is a percentage of nominal motor torque.

| | |
|--|--|
| 4171 MaxPreAlMar Stp A 10% | |
|--|--|

| | |
|----------|--------|
| Default: | 10% |
| Range: | 0-400% |

Communication information

| | |
|----------------------------------|--------------|
| Modbus Instance no/DeviceNet no: | 43327 |
| Profibus slot/index | 169/231 |
| Fieldbus format | Long, 1=0.1% |
| Modbus format | EInt |

Max Pre Alarm delay [4172]

Sets the delay time between the first occurrence of max pre alarm condition and after when the alarm is given.

| | |
|---|--------|
| 4172 MaxPreAlDel Stp A 0.1s | |
| Default: | 0.1 s |
| Range: | 0-90 s |

Communication information

| | |
|----------------------------------|---------------|
| Modbus Instance no/DeviceNet no: | 43331 |
| Profibus slot/index | 169/235 |
| Fieldbus format | Long, 1=0.1 s |
| Modbus format | EInt |

Min Pre Alarm [418]

Min Pre Alarm Margin [4181]

With load type Basic, [415], used the Min Pre-Alarm Margin sets the band under the Normal Load, [41B], menu that does not generate a pre-alarm. With load type Load Curve, [415], used the Min Pre-Alarm Margin sets the band under the Load Curve, [41C], that does not generate a pre-alarm. The Min Pre-Alarm Margin is a percentage of nominal motor torque.

| | |
|--|--------|
| 4181 MinPreAlMar Stp A 10% | |
| Default: | 10% |
| Range: | 0-400% |

Communication information

| | |
|----------------------------------|------------|
| Modbus Instance no/DeviceNet no: | 43328 |
| Profibus slot/index | 169/232 |
| Fieldbus format | Long, 1=1% |
| Modbus format | EInt |

Min Pre Alarm Response delay [4182]

Sets the delay time between the first occurrence of min pre alarm condition and after when the alarm is given.

| | |
|---|--------|
| 4182 MinPreAlDel Stp A 0.1s | |
| Default: | 0.1 s |
| Range: | 0-90 s |

Communication information

| | |
|----------------------------------|---------------|
| Modbus Instance no/DeviceNet no: | 43332 |
| Profibus slot/index | 169/236 |
| Fieldbus format | Long, 1=0.1 s |
| Modbus format | EInt |

Min Alarm [419]

Min Alarm Margin [4191]

With load type Basic, [415], used the Min Alarm Margin sets the band under the Normal Load, [41B], menu that does not generate an alarm. With load type Load Curve, [415], used the Min Alarm Margin sets the band under the Load Curve, [41C], that does not generate an alarm. The Max Alarm Margin is a percentage of nominal motor torque.

| | |
|--|--------|
| 4191 MinAlarmMar Stp A 15% | |
| Default: | 15% |
| Range: | 0-400% |

Communication information

| | |
|----------------------------------|------------|
| Modbus Instance no/DeviceNet no: | 43329 |
| Profibus slot/index | 169/233 |
| Fieldbus format | Long, 1=1% |
| Modbus format | EInt |

Min Alarm Response delay [4192]

Sets the delay time between the first occurrence of min alarm condition and after when the alarm is given.

| | |
|---|--------|
| 4192 MinAlarmDel Stp A 0.1s | |
| Default: | 0.1 s |
| Range: | 0-90 s |

Communication information

| | |
|----------------------------------|---------------|
| Modbus Instance no/DeviceNet no: | 43333 |
| Profibus slot/index | 169/237 |
| Fieldbus format | Long, 1=0.1 s |
| Modbus format | EInt |

Autoset Alarm [41A]

The Autoset Alarm function can measure the nominal load that is used as reference for the alarm levels. If the selected Load Type [415] is Basic it copies the load the motor is running with to the menu Normal Load [41B]. The motor must run on the speed that generates the load that needs to be recorded. If the selected Load Type [415] is Load Curve it performs a test-run and populates the Load Curve [41C] with the found load values.



WARNING!

When autoset does a test run the motor and application/machine will ramp up to maximum speed.

NOTE: The motor must be running for the Autoset Alarm function to succeed. A not running motor generates a "Failed!" message.

| | |
|--|----|
| 41A AutoSet Alarm Stp A No | |
| Default: | No |
| No | 0 |
| Yes | 1 |

Communication information

| | |
|----------------------------------|---------|
| Modbus Instance no/DeviceNet no: | 43334 |
| Profibus slot/index | 169/238 |
| Fieldbus format | UInt |
| Modbus format | UInt |

The default set levels for the (pre)alarms are:

| | | |
|-----------|---------------|---------------------|
| Overload | Max Alarm | menu [4161] + [41B] |
| | Max Pre Alarm | menu [4171] + [41B] |
| Underload | Min Pre Alarm | menu [41B] - [4181] |
| | Min Alarm | menu [41B] - [4191] |

These default set levels can be manually changed in menus [416] to [419]. After execution the message "Autoset OK!" is displayed for 1s and the selection reverts to "No".

Normal Load [41B]

Set the level of the normal load. The alarm or pre alarm will be activated when the load is above/under normal load \pm margin.

| | |
|------------------------|----------------------|
| 41B Normal Load | |
| Stp A 100% | |
| Default: | 100% |
| Range: | 0-400% of max torque |

NOTE: 100% Torque means: $I_{NOM} = I_{MOT}$. The maximum depends on the motor current and AC drive max current settings, but the absolute maximum adjustment is 400%.

Communication information

| | |
|----------------------------------|------------|
| Modbus Instance no/DeviceNet no: | 43335 |
| Profibus slot/index | 169/239 |
| Fieldbus format | Long, 1=1% |
| Modbus format | Elnt |

Load Curve [41C]

The load curve function can be used with any smooth load curve. The curve can be populated with a test-run or the values can be entered or changed manually.

Load Curve 1-9 [41C1]-[41C9]

The measured load curve is based on 9 stored samples. The curve starts at minimum speed and ends at maximum speed, the range in between is divided into 8 equal steps. The measured values of each sample are displayed in [41C1] to [41C9] and can be adapted manually. The value of the 1st sampled value on the load curve is displayed.

| | |
|-------------------------|----------------------|
| 41C1 Load Curve1 | |
| Stp A 0rpm 100% | |
| Default: | 100% |
| Range: | 0-400% of max torque |

Communication information

| | |
|----------------------------------|---|
| Modbus Instance no/DeviceNet no: | 43336%, 43337 rpm, 43338%, 43339 rpm, 43340%, 43341 rpm, 43342%, 43343 rpm, 43344%, 43345 rpm, 43346%, 43347 rpm, 43348%, 43349 rpm, 43350%, 43351 rpm, 43352%, 43353 rpm |
| Profibus slot/index | 169/240, 169/242, 169/244, 169/246, 169/248, 169/250, 169/252, 169/254, 170/1 |
| Fieldbus format | Long |
| Modbus format | Elnt |

NOTE: The speed values depend on the Min- and Max Speed values. they are read only and cannot be changed.

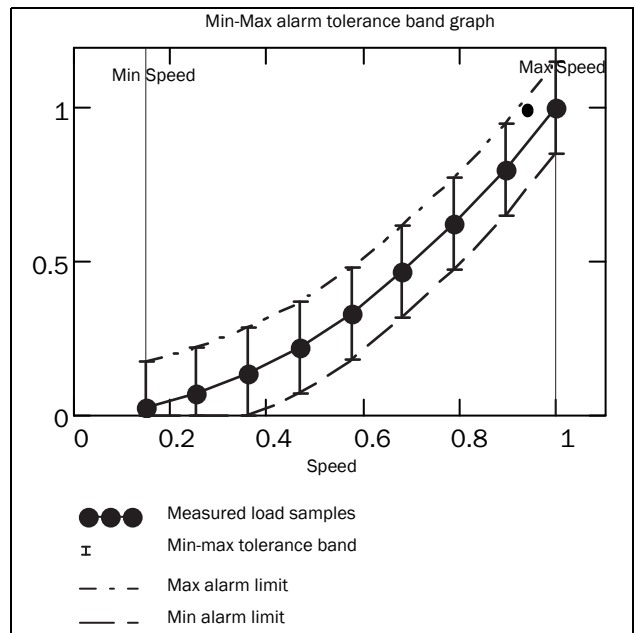

Fig. 91

11.4.2 Process Protection [420]

Submenu with settings regarding protection functions for the AC drive and the motor.

Low Voltage Override [421]

If a dip in the mains supply occurs and the low voltage override function is enabled, the AC drive will automatically decrease the motor speed to keep control of the application and prevent an under voltage trip until the input voltage rises again. Therefore the rotating energy in the motor/load is used to keep the DC link voltage level at the override level, for as long as possible or until the motor comes to a standstill. This is dependent on the inertia of the motor/load combination and the load of the motor at the time the dip occurs, see Fig. 92.

| | | |
|--|----|--|
| 421 Low Volt OR Stp A On | | |
| Default: | On | |
| Off | 0 | At a voltage dip the low voltage trip will protect. |
| On | 1 | At mains dip, AC drive ramps down until voltage rises. |

Communication information

| | |
|----------------------------------|--------|
| Modbus Instance no/DeviceNet no: | 43361 |
| Profibus slot/index | 170/10 |
| Fieldbus format | UInt |
| Modbus format | UInt |

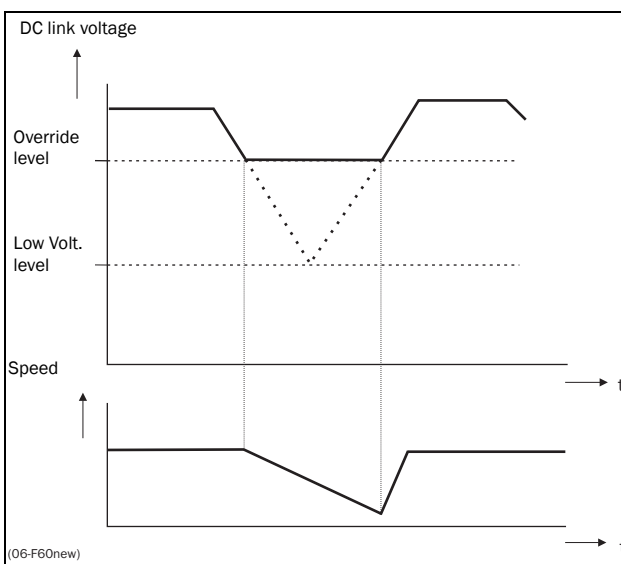

Fig. 92 Low voltage override

NOTE: During the low voltage override the LED trip/limit blinks.

Rotor locked [422]

With the rotor locked function enabled, the AC drive will protect the motor and application when this is stalled whilst increasing the motor speed from standstill. This protection will coast the motor to stop and indicate a fault when the Torque Limit has been active at very low speed for more than 5 seconds.

| | | |
|--|-----|--|
| 422 Rotor locked Stp A Off | | |
| Default: | Off | |
| Off | 0 | No detection |
| On | 1 | AC drive will trip when locked rotor is detected. Trip message "Locked Rotor". |

Communication information

| | |
|----------------------------------|--------|
| Modbus Instance no/DeviceNet no: | 43362 |
| Profibus slot/index | 170/11 |
| Fieldbus format | UInt |
| Modbus format | UInt |

Motor lost [423]

With the motor lost function enabled, the AC drive is able to detect a fault in the motor circuit: motor, motor cable, thermal relay or output filter. Motor lost will cause a trip, and the motor will coast to standstill, when a missing motor phase is detected during a period of 5 s.

| | | |
|--|-----|---|
| 423 Motor lost Stp A Off | | |
| Default: | Off | |
| Off | 0 | Function switched off to be used if no motor or very small motor connected. |
| Trip | 1 | AC drive will trip when the motor is disconnected. Trip message "Motor Lost". |

Communication information

| | |
|----------------------------------|--------|
| Modbus Instance no/DeviceNet no: | 43363 |
| Profibus slot/index | 170/12 |
| Fieldbus format | UInt |
| Modbus format | UInt |

Overvolt control [424]

Used to switch off the overvoltage control function when only braking by brake chopper and resistor is required. The overvoltage control function, limits the braking torque so that the DC link voltage level is controlled at a high, but safe, level. This is achieved by limiting the actual deceleration rate during stopping. In case of a defect at the brake chopper or the brake resistor the AC drive will trip for “Overvoltage” to avoid a fall of the load e.g. in crane applications.

NOTE: Overvoltage control should not be activated if brake chopper is used.

| 424 Over Volt Ctl Stp ^A On | | |
|--|----|-------------------------------|
| Default: | On | |
| On | 0 | Overvoltage control activated |
| Off | 1 | Overvoltage control off |

Communication information

| | |
|----------------------------------|--------|
| Modbus Instance no/DeviceNet no: | 43364 |
| Profibus slot/index | 170/13 |
| Fieldbus format | UInt |
| Modbus format | UInt |

11.5 I/Os and Virtual Connections [500]

Main menu with all the settings of the standard inputs and outputs of the AC drive.

11.5.1 Analogue Inputs [510]

Submenu with all settings for the analogue inputs.

AnIn1 Function [511]

Sets the function for Analogue input 1. Scale and range are defined by AnIn1 Advanced settings [513].

| 511 AnIn1 Fc Stp ^A Process Ref | | |
|--|-------------|--|
| Default: | Process Ref | |
| Off | 0 | Input is not active |
| Max Speed | 1 | The input acts as an upper speed limit. |
| Max Torque | 2 | The input acts as an upper torque limit. |
| Process Val | 3 | The input value equals the actual process value (feedback) and is compared to the reference signal (set point) by the PID controller, or can be used to display and view the actual process value. |
| Process Ref | 4 | Reference value is set for control in process units, see Process Source [321] and Process Unit [322]. |

Communication information

| | |
|----------------------------------|---------|
| Modbus Instance no/DeviceNet no: | 43201 |
| Profibus slot/index | 169/105 |
| Fieldbus format | UInt |
| Modbus format | UInt |

NOTE: When AnInX Func=Off, the connected signal will still be available for Comparators [610].

Adding analogue inputs

If more than one analogue input is set to the same function, the values of the inputs can be added together. In the following examples we assume that Process Source [321] is set to Speed.

Example 1: Add signals with different weight (fine tuning).

Signal on AnIn1 = 10 mA

Signal on AnIn2 = 5 mA

[511] AnIn1 Function = Process Ref.

[512] AnIn1 Setup = 4-20 mA

[5134] AnIn1 Function Min = Min (0 rpm)

[5136] AnIn1 Function Max = Max (1500 rpm)

[5138] AnIn1 Operation = Add+

[514] AnIn2 Function = Process Ref.

[515] AnIn2 Setup = 4-20 mA
 [5164] AnIn2 Function Min = Min (0 rpm)
 [5166] AnIn2 Function Max = User defined
 [5167] AnIn2 Value Max = 300 rpm
 [5168] AnIn2 Operation = Add+

Calculation:

$$\text{AnIn1} = (10-4) / (20-4) \times (1500-0) + 0 = 562.5 \text{ rpm}$$

$$\text{AnIn2} = (5-4) / (20-4) \times (300-0) + 0 = 18.75 \text{ rpm}$$

The actual process reference will be:

$$+562.5 + 18.75 = 581 \text{ rpm}$$

Analogue Input Selection via Digital Inputs:

When two different external Reference signals are used, e.g. 4-20mA signal from control centre and a 0-10 V locally mounted potentiometer, it is possible to switch between these two different analogue input signals via a Digital Input set to "AnIn Select".

AnIn1 is 4-20 mA

AnIn2 is 0-10 V

DigIn3 is controlling the AnIn selection; HIGH is 4-20 mA, LOW is 0-10 V

[511] AnIn1 Fc = Process Ref;
 set AnIn1 as reference signal input

[512] AnIn1 Setup = 4-20mA;
 set AnIn1 for a current reference signal

[513A] AnIn1 Enable = DigIn;
 set AnIn1 to be active when DigIn3 is HIGH

[514] AnIn2 Fc = Process Ref;
 set AnIn2 as reference signal input

[515] AnIn2 Setup = 0-10V;
 set AnIn2 for a voltage reference signal

[516A] AnIn2 Enabl = !DigIn;
 set AnIn2 to be active when DigIn3 is LOW

[523] DigIn3=AnIn;
 set DigIn3 as input for selection of AI reference

Subtracting analogue inputs

Example 2: Subtract two signals

Signal on AnIn1 = 8 V

Signal on AnIn2 = 4 V

[511] AnIn1 Function = Process Ref.

[512] AnIn1 Setup = 0-10 V

[5134] AnIn1 Function Min = Min (0 rpm)

[5136] AnIn1 Function Max = Max (1500 rpm)

[5138] AnIn1 Operation = Add+

[514] AnIn2 Function = Process Ref.

[515] AnIn2 Setup = 0-10 V

[5164] AnIn2 Function Min = Min (0 rpm)

[5166] AnIn2 Function Max = Max (1500 rpm)

[5168] AnIn2 Operation = Sub-

Calculation:

$$\text{AnIn1} = (8-0) / (10-0) \times (1500-0) + 0 = 1200 \text{ rpm}$$

$$\text{AnIn2} = (4-0) / (10-0) \times (1500-0) + 0 = 600 \text{ rpm}$$

The actual process reference will be:

$$+1200 - 600 = 600 \text{ rpm}$$

AnIn1 Setup [512]

The analogue input setup is used to configure the analogue input in accordance with the signal used that will be connected to the analogue input. With this selection the input can be determined as current (4-20 mA) or voltage (0-10 V) controlled input. Other selections are available for using a threshold (live zero), a bipolar input function, or a user defined input range. With a bipolar input reference signal, it is possible to control the motor in two directions. See Fig. 93.

NOTE: The selection of voltage or current input is done with S1. When the switch is in voltage mode only the voltage menu items are selectable. With the switch in current mode only the current menu items are selectable.

| 512 AnIn1 Setup | | |
|------------------------|---|---|
| Stp A | | 4-20mA |
| Default: | | 4-20 mA |
| Dependent on | | Setting of switch S1 |
| 4-20mA | 0 | The current input has a fixed threshold (Live Zero) of 4 mA and controls the full range for the input signal. See Fig. 95. |
| 0-20mA | 1 | Normal full current scale configuration of the input that controls the full range for the input signal. See Fig. 94. |
| User mA | 2 | The scale of the current controlled input, that controls the full range for the input signal. Can be defined by the advanced AnIn Min and AnIn Max menus. |
| User Bipol mA | 3 | Sets the input for a bipolar current input, where the scale controls the range for the input signal. Scale can be defined in advanced menu AnIn Bipol. |
| 0-10V | 4 | Normal full voltage scale configuration of the input that controls the full range for the input signal. See Fig. 94. |
| 2-10V | 5 | The voltage input has a fixed threshold (Live Zero) of 2 V and controls the full range for the input signal. See Fig. 95. |
| User V | 6 | The scale of the voltage controlled input, that controls the full range for the input signal. Can be defined by the advanced AnIn Min and AnIn Max menus. |
| User Bipol V | 7 | Sets the input for a bipolar voltage input, where the scale controls the range for the input signal. Scale can be defined in advanced menu AnIn Bipol. |

NOTE: For bipolar function, input RunR and RunL needs to be active and Rotation, [219] must be set to "R+L".

NOTE: Always check the needed set up when the setting of S1 is changed; selection will not adapt automatically.

Communication information

| | |
|----------------------------------|---------|
| Modbus Instance no/DeviceNet no: | 43202 |
| Profibus slot/index | 169/106 |
| Fieldbus format | UInt |
| Modbus format | UInt |

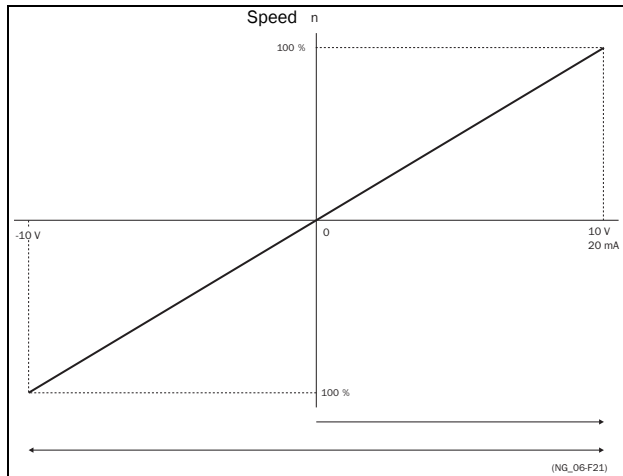

Fig. 93

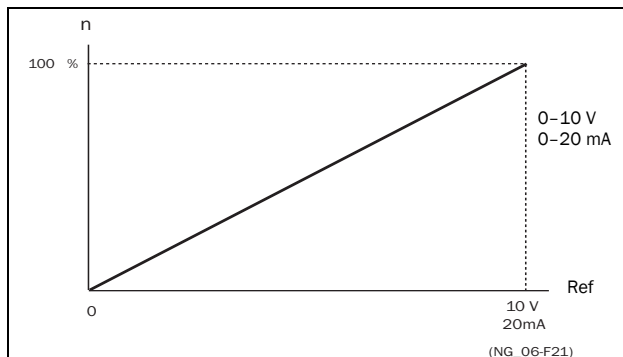

Fig. 94 Normal full-scale configuration

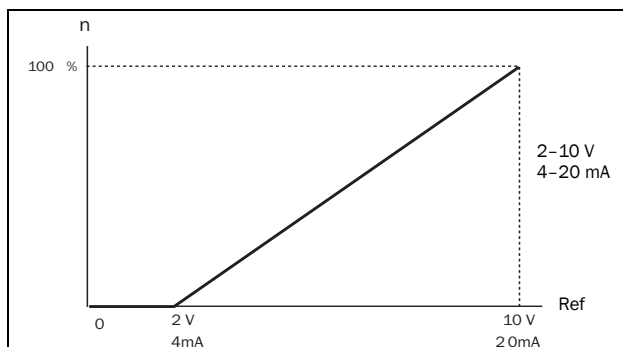

Fig. 95 2-10 V/4-20 mA (Live Zero)

AnIn1 Advanced [513]

NOTE: The different menus will automatically be set to either “mA” or “V”, based on the selection in AnIn 1 Setup [512].

| |
|--|
| 513 AnIn1 Advan Stp A |
|--|

AnIn1 Min [5131]

Parameter to set the minimum value of the external reference signal. Only visible if [512] = User mA/V.

| | |
|--|----------------------------|
| 5131 AnIn1 Min Stp A 0V/4.00mA | |
| Default: | 0 V/4.00 mA |
| Range: | 0.00-20.00 mA 0-10.00 V |

Communication information

| | |
|----------------------------------|---------|
| Modbus Instance no/DeviceNet no: | 43203 |
| Profibus slot/index | 169/107 |
| Fieldbus format | Long |
| Modbus format | EInt |

AnIn1 Max [5132]

Parameter to set the maximum value of the external reference signal. Only visible if [512] = User mA/V.

| | |
|---|----------------------------|
| 5132 AnIn1 Max Stp 10.0V/20.00mA | |
| Default: | 10.00 V/20.00 mA |
| Range: | 0.00-20.00 mA 0-10.00 V |

Communication information

| | |
|----------------------------------|---------|
| Modbus Instance no/DeviceNet no: | 43204 |
| Profibus slot/index | 169/108 |
| Fieldbus format | Long |
| Modbus format | EInt |

Special function: Inverted reference signal

If the AnIn minimum value is higher than the AnIn maximum value, the input will act as an inverted reference input, see Fig. 96.

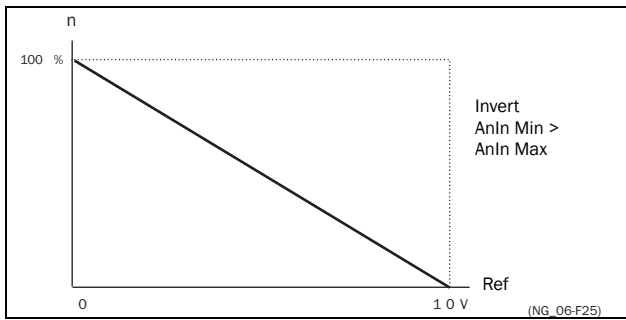

Fig. 96 Inverted reference

AnIn1 Bipol [5133]

This menu is automatically displayed if AnIn1 Setup is set to User Bipol mA or User Bipol V. The window will automatically show mA or V range according to selected function. The range is set by changing the positive maximum value; the negative value is automatically adapted accordingly. Only visible if [512] = User Bipol mA/V. The inputs RunR and RunL input need to be active, and Rotation, [219], must be set to "R+L", to operate the bipolar function on the analogue input.

| | |
|--|---------------------------|
| 5133 AnIn1 Bipol Stp A 10.00V/20.00mA | |
| Default: | 10.00 V/20.00 mA |
| Range: | 0.0-20.0 mA, 0.00-10.00 V |

Communication information

| | |
|----------------------------------|---------|
| Modbus Instance no/DeviceNet no: | 43205 |
| Profibus slot/index | 169/109 |
| Fieldbus format | Long |
| Modbus format | EInt |

AnIn1 Function Min [5134]

With AnIn1 Function Min the physical minimum value is scaled to selected process unit. The default scaling is dependent of the selected function of AnIn1 [511].

| | | |
|--|-----|----------------------------------|
| 5134 AnIn1 FcMin Stp A Min | | |
| Default: | Min | |
| Min | 0 | Min value |
| Max | 1 | Max value |
| User-defined | 2 | Define user value in menu [5135] |

Table 25 shows corresponding values for the min and max selections depending on the function of the analogue input [511].

Table 25

| AnIn Function | Min | Max |
|---------------|-------------------|-------------------|
| Speed | Min Speed [341] | Max Speed [343] |
| Torque | 0% | Max Torque [351] |
| Process Ref | Process Min [324] | Process Max [325] |
| Process Value | Process Min [324] | Process Max [325] |

Communication information

| | |
|----------------------------------|---------|
| Modbus Instance no/DeviceNet no: | 43206 |
| Profibus slot/index | 169/110 |
| Fieldbus format | UInt |
| Modbus format | UInt |

AnIn1 Function Value Min [5135]

With AnIn1 Function ValMin you define a user-defined value for the signal. Only visible when user-defined is selected in menu [5134].

| | |
|--|------------------------|
| 5135 AnIn1 VaMin Stp A 0.000 | |
| Default: | 0.000 |
| Range: | -10000.000 - 10000.000 |

Communication information

| | |
|----------------------------------|--|
| Modbus Instance no/DeviceNet no: | 43541 |
| Profibus slot/index | 170/190 |
| Fieldbus format | Long, Speed 1=1 rpm Torque 1=1% Process val 1=0.001 |
| Modbus format | EInt |

AnIn1 Function Max [5136]

With AnIn1 Function Max the physical maximum value is scaled to selected process unit. The default scaling is dependent of the selected function of AnIn1 [511]. See Table 25.

| | | |
|--|---|----------------------------------|
| 5136 AnIn1 FcMax Stp A Max | | |
| Default: | | Max |
| Min | 0 | Min value |
| Max | 1 | Max value |
| User-defined | 2 | Define user value in menu [5137] |

Communication information

| | |
|--------------------------------------|---|
| Modbus Instance no/ DeviceNet no: | 43207 |
| Profibus slot/index | 169/111 |
| Fieldbus format | Long, Speed/Torque 1=1 rpm or %. Other 1= 0.001 |
| Modbus format | Elnt |

AnIn1 Function Value Max [5137]

With AnIn1 Function VaMax you define a user-defined value for the signal. Only visible when user-defined is selected in menu [5136].

| | |
|--|------------------------|
| 5137 AnIn1 VaMax Stp A 0.000 | |
| Default: | 0.000 |
| Range: | -10000.000 - 10000.000 |

Communication information

| | |
|----------------------------------|--|
| Modbus Instance no/DeviceNet no: | 43551 |
| Profibus slot/index | 170/200 |
| Fieldbus format | Long, Speed 1=1 rpm Torque 1=1% Process val 1=0.001 |
| Modbus format | Elnt |

NOTE: With AnIn Min, AnIn Max, AnIn Function Min and AnIn Function Max settings, loss of feedback signals (e.g. voltage drop due to long sensor wiring) can be compensated to ensure an accurate process control.

Example:

Process sensor is a sensor with the following specification:

Range: 0–3 bar
Output: 2–10 mA

Analogue input should be set up according to:

- [512] AnIn1 Setup = User mA
- [5131] AnIn1 Min = 2 mA
- [5132] AnIn1 Max = 10 mA
- [5134] AnIn1 Function Min = User-defined
- [5135] AnIn1 VaMin = 0.000 bar
- [5136] AnIn 1 Function Max = User-defined
- [5137] AnIn1 VaMax = 3.000 bar

AnIn1 Operation [5138]

| | | |
|--|---|---|
| 5138 AnIn1 Oper Stp A Add+ | | |
| Default: | | Add+ |
| Add+ | 0 | Analogue signal is added to selected function in menu [511]. |
| Sub- | 1 | Analogue signal is subtracted from selected function in menu [511]. |

Communication information

| | |
|----------------------------------|---------|
| Modbus Instance no/DeviceNet no: | 43208 |
| Profibus slot/index | 169/112 |
| Fieldbus format | UInt |
| Modbus format | UInt |

AnIn1 Filter [5139]

If the input signal is unstable (e.g. fluctuation reference value), the filter can be used to stabilize the signal. A change of the input signal will reach 63% on AnIn1 within the set AnIn1 Filter time. After 5 times the set time, AnIn1 will have reached 100% of the input change. See Fig. 97.

| | |
|--|----------------|
| 5139 AnIn1 Filt Stp A 0.1s | |
| Default: | 0.1 s |
| Range: | 0.001 - 10.0 s |

Communication information

| | |
|----------------------------------|-----------------|
| Modbus Instance no/DeviceNet no: | 43209 |
| Profibus slot/index | 169/113 |
| Fieldbus format | Long, 1=0.001 s |
| Modbus format | Elnt |

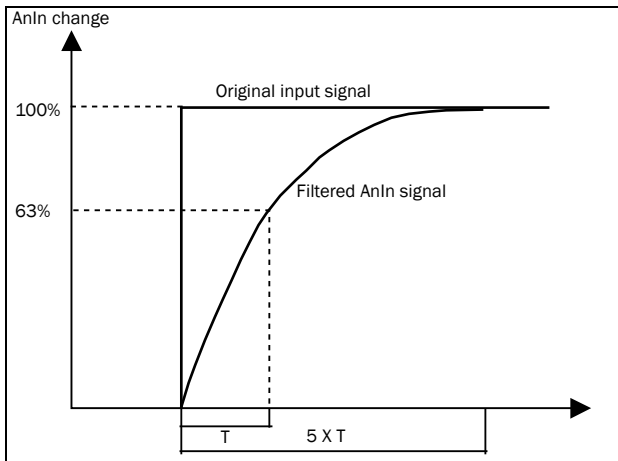

Fig. 97

AnIn1 Enable [513A]

Parameter for enable/disable analogue input selection via digital inputs (DigIn set to function AnIn Select).

| | |
|-------------------------|--|
| 513A AnIn1 Enabl | |
| Stp A On | |
| Default: | On |
| On | 0 AnIn1 is always active |
| !DigIn | 1 AnIn1 is only active if the digital input is low. |
| DigIn | 2 AnIn1 is only active if the digital input is high. |

Communication information

| | |
|----------------------------------|---------------|
| Modbus Instance no/DeviceNet no: | AnIn1 43210 |
| Profibus slot/index | AnIn1 169/114 |
| Fieldbus format | UInt |
| Modbus format | UInt |

AnIn2 Function [514]

Parameter for setting the function of Analogue Input 2. Same function as AnIn1 Func [511].

| | |
|-------------------------|-----------------------|
| 514 AnIn2 Fc | |
| Stp A Off | |
| Default: | Off |
| Selection: | Same as in menu [511] |

Communication information

| | |
|----------------------------------|---------|
| Modbus Instance no/DeviceNet no: | 43211 |
| Profibus slot/index | 169/115 |
| Fieldbus format | UInt |
| Modbus format | UInt |

AnIn2 Setup [515]

Parameter for setting the function of Analogue Input 2. Same functions as AnIn1 Setup [512].

| | |
|------------------------------|------------------------|
| 515 AnIn2 Setup | |
| Stp A 4 - 20mA | |
| Default: | 4 - 20 mA |
| Dependent on | Setting of switch S2 |
| Selection: | Same as in menu [512]. |

Communication information

| | |
|----------------------------------|---------|
| Modbus Instance no/DeviceNet no: | 43212 |
| Profibus slot/index | 169/116 |
| Fieldbus format | UInt |
| Modbus format | UInt |

AnIn2 Advanced [516]

Same functions and submenus as under AnIn1 Advanced [513].

| | |
|------------------------|--|
| 516 AnIn2 Advan | |
| Stp A | |

Communication information

| | |
|----------------------------------|-----------------------------------|
| Modbus Instance no/DeviceNet no: | 43213-43220 43542 43552 |
| Profibus slot/index | 169/117-124 170/191 170/201 |

AnIn3 Function [517]

Parameter for setting the function of Analogue Input 3. Same function as AnIn1 Func [511].

| | |
|-------------------------|-----------------------|
| 517 AnIn3 Fc | |
| Stp A Off | |
| Default: | Off |
| Selection: | Same as in menu [511] |

Communication information

| | |
|----------------------------------|---------|
| Modbus Instance no/DeviceNet no: | 43221 |
| Profibus slot/index | 169/125 |
| Fieldbus format | UInt |
| Modbus format | UInt |

AnIn3 Setup [518]

Same functions as AnIn1 Setup [512].

| | |
|---|------------------------|
| 518 AnIn3 Setup Stp A 4-20mA | |
| Default: | 4-20 mA |
| Dependent on | Setting of switch S3 |
| Selection: | Same as in menu [512]. |

Communication information

| | |
|----------------------------------|---------|
| Modbus Instance no/DeviceNet no: | 43222 |
| Profibus slot/index | 169/126 |
| Fieldbus format | UInt |
| Modbus format | UInt |

AnIn3 Advanced [519]

Same functions and submenus as under AnIn1 Advanced [513].

| | |
|--|--|
| 519 AnIn3 Advan Stp A | |
|--|--|

Communication information

| | |
|----------------------------------|---------------------------------------|
| Modbus Instance no/DeviceNet no: | 43223-43230 43543 43553 |
| Profibus slot/index | 169/127-169/134 170/192 170/202 |

AnIn4 Function [51A]

Parameter for setting the function of Analogue Input 4.

Same function as AnIn1 Func [511].

| | |
|---|-----------------------|
| 51A AnIn4 Fc Stp A Off | |
| Default: | Off |
| Selection: | Same as in menu [511] |

Communication information

| | |
|----------------------------------|---------|
| Modbus Instance no/DeviceNet no: | 43231 |
| Profibus slot/index | 169/135 |
| Fieldbus format | UInt |
| Modbus format | UInt |

AnIn4 Set-up [51B]

Same functions as AnIn1 Setup [512].

| | |
|---|------------------------|
| 51B AnIn4 Setup Stp A 4-20mA | |
| Default: | 4-20 mA |
| Dependent on | Setting of switch S4 |
| Selection: | Same as in menu [512]. |

Communication information

| | |
|----------------------------------|---------|
| Modbus Instance no/DeviceNet no: | 43232 |
| Profibus slot/index | 169/136 |
| Fieldbus format | UInt |
| Modbus format | UInt |

AnIn4 Advanced [51C]

Same functions and submenus as under AnIn1 Advanced [513].

| | |
|--|--|
| 51C AnIn4 Advan Stp A | |
|--|--|

Communication information

| | |
|----------------------------------|-----------------------------------|
| Modbus Instance no/DeviceNet no: | 43233-43240 43544 43554 |
| Profibus slot/index | 169/137-144 170/193 170/203 |

11.5.2 Digital Inputs [520]

Submenu with all the settings for the digital inputs.

NOTE: Additional inputs will become available when the I/O option boards are connected.

Digital Input 1 [521]

To select the function of the digital input.

On the standard control board there are eight digital inputs.

If the same function is programmed for more than one input that function will be activated according to “OR” logic if nothing else is stated.

| 521 DigIn 1 | | |
|--------------|----|--|
| | | StpA RunL |
| Default: | | RunL |
| Off | 0 | The input is not active. |
| Lim Switch+ | 1 | AC drive ramps to stop and prevents rotation in “R” direction (clockwise), when the signal is low! NOTE: The Lim Switch+ is active low. NOTE: Activated according to “AND” logic. |
| Lim Switch - | 2 | AC drive ramps to stop and prevents rotation in “L” direction (counter clockwise) when the signal is low! NOTE: The Lim Switch- is active low. NOTE: Activated according to “AND” logic. |
| Ext. Trip | 3 | Be aware that if there is nothing connected to the input, the AC drive will trip at “External trip” immediately. NOTE: The External Trip is active low. NOTE: Activated according to “AND” logic. |
| Stop | 4 | Stop command according to the selected Stop mode in menu [33B]. NOTE: The Stop command is active low. NOTE: Activated according to “AND” logic. |
| Enable | 5 | Enable command. General start condition to run the AC drive. If made low during running the output of the AC drive is cut off immediately, causing the motor to coast to zero speed. NOTE: If none of the digital inputs are programmed to “Enable”, the internal enable signal is active. NOTE: Activated according to “AND” logic. |
| RunR | 6 | Run Right command (positive speed). The output of the AC drive will be a clockwise rotary field. |
| RunL | 7 | Run Left command (negative speed). The output of the AC drive will be a counter-clockwise rotary field. |
| Reset | 9 | Reset command. To reset a Trip condition and to enable the Autoreset function. |
| Preset Ctrl1 | 10 | To select the Preset Reference. |

| | | |
|--------------|----|---|
| Preset Ctrl2 | 11 | To select the Preset Reference. |
| Preset Ctrl3 | 12 | To select the Preset Reference. |
| MotPot Up | 13 | Increases the internal reference value according to the set AccMotPot time [333]. Has the same function as a “real” motor potentiometer, see Fig. 78. |
| MotPot Down | 14 | Decreases the internal reference value according to the set DecMotPot time [334]. See MotPot Up. |
| Pump1 Feedb | 15 | Feedback input pump1 for Pump/Fan control and informs about the status of the auxiliary connected pump/fan. |
| Pump2 Feedb | 16 | Feedback input pump 2 for Pump/Fan control and informs about the status of the auxiliary connected pump/fan. |
| Pump3 Feedb | 17 | Feedback input pump3 for Pump/Fan control and informs about the status of the auxiliary connected pump/fan. |
| Pump4 Feedb | 18 | Feedback input pump 4 for Pump/Fan control and informs about the status of the auxiliary connected pump/fan. |
| Pump5 Feedb | 19 | Feedback input pump5 for Pump/Fan control and informs about the status of the auxiliary connected pump/fan. |
| Pump6 Feedb | 20 | Feedback input pump 6 for Pump/Fan control and informs about the status of the auxiliary connected pump/fan. |
| Timer 1 | 21 | Timer 1 Delay [643] will be activated on the rising edge of this signal. |
| Timer 2 | 22 | Timer 2 Delay [653] will be activated on the rising edge of this signal. |
| Set Ctrl 1 | 23 | Activates other parameter set. See Table 26 for selection possibilities. |
| Set Ctrl 2 | 24 | Activates other parameter set. See Table 26 for selection possibilities. |
| Mot PreMag | 25 | Pre-magnetises the motor. Used for faster motor start. |
| Jog | 26 | To activate the Jog function. Gives a Run command with the set Jog speed and Direction, page 95. |
| Ext Mot Temp | 27 | Be aware that if there is nothing connected to the input, the AC drive will trip at “External Motor Temp” immediately. NOTE: The External Motor Temp is active low. |
| Loc/Rem | 28 | Activate local mode defined in [2171] and [2172]. |
| AnIn select | 29 | Activate/deactivate analogue inputs defined in [513A], [516A], [519A] and [51CA] |
| LC Level | 30 | Liquid cooling low level signal. NOTE: The Liquid Cooling Level is active low. |

| | | |
|----------|----|--|
| Brk Ackn | 31 | Brake acknowledge input for Brake Fault control. Function is activated via this selection see menu [33H] page 92 |
|----------|----|--|

NOTE: For bipolar function, input RunR and RunL needs to be active and Rotation, [219] must be set to "R+L".

Communication information

| | |
|----------------------------------|---------|
| Modbus Instance no/DeviceNet no: | 43241 |
| Profibus slot/index | 169/145 |
| Fieldbus format | UInt |
| Modbus format | UInt |

Table 26

| Parameter Set | Set Ctrl 1 | Set Ctrl 2 |
|---------------|------------|------------|
| A | 0 | 0 |
| B | 1 | 0 |
| C | 0 | 1 |
| D | 1 | 1 |

NOTE: To activate the parameter set selection, menu 241 must be set to DigIn.

Digital Input 2 [522] to Digital Input 8 [528]

Same function as DigIn 1 [521]. Default function for DigIn 8 is Reset. For DigIn 3 to 7 the default function is Off.

| | |
|---------------------------|-----------------------|
| 522 DigIn 2 | |
| Stp A Run R | |
| Default: | RunR |
| Selection: | Same as in menu [521] |

Communication information

| | |
|----------------------------------|-----------------|
| Modbus Instance no/DeviceNet no: | 43241-43248 |
| Profibus slot/index | 169/146-169/152 |
| Fieldbus format | UInt |
| Modbus format | UInt |

Additional digital inputs [529] to [52H]

Additional digital inputs with I/O option board installed, B1 DigIn 1 [529] - B3 DigIn 3 [52H]. B stands for board and 1 to 3 is the number of the board which is related to the position of the I/O option board on the option mounting plate. The functions and selections are the same as DigIn 1 [521].

Communication information

| | |
|----------------------------------|-----------------|
| Modbus Instance no/DeviceNet no: | 43501-43509 |
| Profibus slot/index | 170/150-170/158 |
| Fieldbus format | Int |
| Modbus format | Int |

11.5.3 Analogue Outputs [530]

Submenu with all settings for the analogue outputs. Selections can be made from application and AC drive values, in order to visualize actual status. Analogue outputs can also be used as a mirror of the analogue input. Such a signal can be used as:

- a reference signal for the next AC drive in a Master/ Slave configuration (see Fig. 98).
- a feedback acknowledgement of the received analogue reference value.

AnOut1 Function [531]

Sets the function for the Analogue Output 1. Scale and range are defined by AnOut1 Advanced settings [533].

| 531 AnOut1 Fc Stp _A Speed | | |
|---|----|--|
| Default: | | Speed |
| Process Val | 0 | Actual process value according to Process feedback signal. |
| Speed | 1 | Actual speed. |
| Torque | 2 | Actual torque. |
| Process Ref | 3 | Actual process reference value. |
| Shaft Power | 4 | Actual shaft power. |
| Frequency | 5 | Actual frequency. |
| Current | 6 | Actual current. |
| EI power | 7 | Actual electrical power. |
| Output volt | 8 | Actual output voltage. |
| DC-voltage | 9 | Actual DC link voltage. |
| AnIn1 | 10 | Mirror of received signal value on AnIn1. |
| AnIn2 | 11 | Mirror of received signal value on AnIn2. |
| AnIn3 | 12 | Mirror of received signal value on AnIn3. |
| AnIn4 | 13 | Mirror of received signal value on AnIn4. |
| Speed Ref | 14 | Actual internal speed reference Value after ramp and V/Hz. |
| Torque Ref | 15 | Actual torque reference value (=0 in V/Hz mode) |

NOTE: When selections AnIn1, AnIn2 AnIn4 is selected, the setup of the AnOut (menu [532] or [535]) has to be set to 0-10V or 0-20mA. When the AnOut Setup is set to e.g. 4-20mA, the mirroring is not working correct.

Communication information

| | |
|----------------------------------|---------|
| Modbus Instance no/DeviceNet no: | 43251 |
| Profibus slot/index | 169/155 |
| Fieldbus format | UInt |
| Modbus format | UInt |

AnOut 1 Setup [532]

Preset scaling and offset of the output configuration.

| 532 AnOut1 Setup Stp _A 4-20mA | | |
|---|---|--|
| Default: | | 4-20mA |
| 4-20mA | 0 | The current output has a fixed threshold (Live Zero) of 4 mA and controls the full range for the output signal. See Fig. 95. |
| 0-20mA | 1 | Normal full current scale configuration of the output that controls the full range for the output signal. See Fig. 94. |
| User mA | 2 | The scale of the current controlled output that controls the full range for the output signal. Can be defined by the advanced AnOut Min and AnOut Max menus. |
| User Bipol mA | 3 | Sets the output for a bipolar current output, where the scale controls the range for the output signal. Scale can be defined in advanced menu AnOut Bipol. |
| 0-10V | 4 | Normal full voltage scale configuration of the output that controls the full range for the output signal. See Fig. 94. |
| 2-10V | 5 | The voltage output has a fixed threshold (Live Zero) of 2 V and controls the full range for the output signal. See Fig. 95. |
| User V | 6 | The scale of the voltage controlled output that controls the full range for the output signal. Can be defined by the advanced AnOut Min and AnOut Max menus. |
| User Bipol V | 7 | Sets the output for a bipolar voltage output, where the scale controls the range for the output signal. Scale can be defined in advanced menu AnOut Bipol. |

Communication information

| | |
|----------------------------------|---------|
| Modbus Instance no/DeviceNet no: | 43252 |
| Profibus slot/index | 169/156 |
| Fieldbus format | UInt |
| Modbus format | UInt |

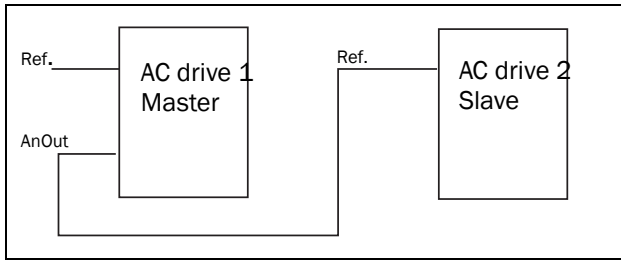

Fig. 98

AnOut1 Advanced [533]

With the functions in the AnOut1 Advanced menu, the output can be completely defined according to the application needs. The menus will automatically be adapted to “mA” or “V”, according to the selection in AnOut1 Setup [532].

| |
|--|
| 533 AnOut 1 Adv Stp A |
|--|

AnOut1 Min [5331]

This parameter is automatically displayed if User mA or User V is selected in menu AnOut 1 Setup [532]. The menu will automatically adapt to current or voltage setting according to the selected setup. Only visible if [532] = User mA/V.

| | |
|--|------------------------------|
| 5331 AnOut 1 Min Stp A 4mA | |
| Default: | 4 mA |
| Range: | 0.00 - 20.00 mA, 0 - 10.00 V |

Communication information

| | |
|----------------------------------|--------------|
| Modbus Instance no/DeviceNet no: | 43253 |
| Profibus slot/index | 169/157 |
| Fieldbus format | Long, 1=0.01 |
| Modbus format | Elnt |

AnOut1 Max [5332]

This parameter is automatically displayed if User mA or User V is selected in menu AnOut1 Setup [532]. The menu will automatically adapt to current or voltage setting according to the selected setup. Only visible if [532] = User mA/V.

| | |
|--|--------------------------|
| 5332 AnOut 1 Max Stp 20.0mA | |
| Default: | 20.00 mA |
| Range: | 0.00-20.00 mA, 0-10.00 V |

Communication information

| | |
|----------------------------------|--------------|
| Modbus Instance no/DeviceNet no: | 43254 |
| Profibus slot/index | 169/158 |
| Fieldbus format | Long, 1=0.01 |
| Modbus format | Elnt |

AnOut1 Bipol [5333]

Automatically displayed if User Bipol mA or User Bipol V is selected in menu AnOut1 Setup. The menu will automatically show mA or V range according to the selected function. The range is set by changing the positive maximum value; the negative value is automatically adapted accordingly. Only visible if [512] = User Bipol mA/V.

| | |
|---|-------------------------------|
| 5333 AnOut1Bipol Stp -10.00-10.00V | |
| Default: | -10.00-10.00 V |
| Range: | -10.00-10.00 V, -20.0-20.0 mA |

Communication information

| | |
|----------------------------------|--------------|
| Modbus Instance no/DeviceNet no: | 43255 |
| Profibus slot/index | 169/159 |
| Fieldbus format | Long, 1=0.01 |
| Modbus format | Elnt |

AnOut1 Function Min [5334]

With AnOut1 Function Min the physical minimum value is scaled to selected presentation. The default scaling is dependent of the selected function of AnOut1 [531].

| | | |
|--|-----|----------------------------------|
| 5334 AnOut1FCMin Stp A Min | | |
| Default: | Min | |
| Min | 0 | Min value |
| Max | 1 | Max value |
| User-defined | 2 | Define user value in menu [5335] |

Table 27 shows corresponding values for the min and max selections depending on the function of the analogue output [531].

Table 27

| AnOut Function | Min Value | Max Value |
|----------------|--------------------|-----------------------|
| Process Value | Process Min [324] | Process Max [325] |
| Speed | Min Speed [341] | Max Speed [343] |
| Torque | 0% | Max Torque [351] |
| Process Ref | Process Min [324] | Process Max [325] |
| Shaft Power | 0% | Motor Power [223] |
| Frequency | Fmin * | Motor Frequency [222] |
| Current | 0 A | Motor Current [224] |
| El Power | 0 W | Motor Power [223] |
| Output Voltage | 0 V | Motor Voltage [221] |
| DC voltage | 0 V | 1000 V |
| AnIn1 | AnIn1 Function Min | AnIn1 Function Max |
| AnIn2 | AnIn2 Function Min | AnIn2 Function Max |
| AnIn3 | AnIn3 Function Min | AnIn3 Function Max |
| AnIn4 | AnIn4 Function Min | AnIn4 Function Max |

*) Fmin is dependent on the set value in menu "Minimum Speed [341]".

Communication information

| | |
|----------------------------------|--|
| Modbus Instance no/DeviceNet no: | 43256 |
| Profibus slot/index | 169/160 |
| Fieldbus format | Long, 1=0.1 W, 0.1 Hz, 0.1 A, 0.1 V or 0.001 |
| Modbus format | Elnt |

Example

Set the AnOut function for Motorfrequency to 0Hz, set AnOut functionMin [5334] to "User-defined" and AnOut1 VaMin[5335] = 0.0. This results in an analogue output signal from 0/4 mA to 20mA: 0Hz to Fmot. This principle is valid for all Min to Max settings.

AnOut1 Function Value Min [5335]

With AnOut1 Function VaMin you define a user-defined value for the signal. Only visible when user-defined is selected in menu [5334].

| | |
|--|----------------------|
| 5335 AnOut1VaMin Stp A 0.000 | |
| Default: | 0.000 |
| Range: | -10000.000-10000.000 |

Communication information

| | |
|----------------------------------|--|
| Modbus Instance no/DeviceNet no: | 43545 |
| Profibus slot/index | 170/194 |
| Fieldbus format | Long, Speed 1=1 rpm Torque 1=1% Process val 1=0.001 |
| Modbus format | Elnt |

AnOut1 Function Max [5336]

With AnOut1 Function Min the physical minimum value is scaled to selected presentation. The default scaling is dependent on the selected function of AnOut1 [531]. See Table 27.

| | | |
|--|-----|----------------------------------|
| 5336 AnOut1FCMax Stp A Max | | |
| Default: | Max | |
| Min | 0 | Min value |
| Max | 1 | Max value |
| User defined | 2 | Define user value in menu [5337] |

Communication information

| | |
|----------------------------------|-------------|
| Modbus Instance no/DeviceNet no: | 43257 |
| Profibus slot/index | 169/161 |
| Fieldbus format | Long, 0.001 |
| Modbus format | Elnt |

NOTE: It is possible to set AnOut1 up as an inverted output signal by setting AnOut1 Min > AnOut1 Max. See Fig. 96.

AnOut1 Function Value Max [5337]

With AnOut1 Function VaMax you define a user-defined value for the signal. Only visible when user-defined is selected in menu [5334].

| | |
|--|----------------------|
| 5337 AnOut1VaMax Stp A 0.000 | |
| Default: | 0.000 |
| Range: | -10000.000-10000.000 |

Communication information

| | |
|----------------------------------|--|
| Modbus Instance no/DeviceNet no: | 43555 |
| Profibus slot/index | 170/204 |
| Fieldbus format | Long, Speed 1=1 rpm Torque 1=1% Process val 1=0.001 |
| Modbus format | Elnt |

AnOut2 Function [534]

Sets the function for the Analogue Output 2.

| | |
|--|-----------------------|
| 534 AnOut2 Fc Stp A Torque | |
| Default: | Torque |
| Selection: | Same as in menu [531] |

Communication information

| | |
|----------------------------------|---------|
| Modbus Instance no/DeviceNet no: | 43261 |
| Profibus slot/index | 169/165 |
| Fieldbus format | UInt |
| Modbus format | UInt |

AnOut2 Setup [535]

Preset scaling and offset of the output configuration for analogue output 2.

| | |
|---|-----------------------|
| 535 AnOut2 Setup Stp A 4-20mA | |
| Default: | 4-20mA |
| Selection: | Same as in menu [532] |

Communication information

| | |
|----------------------------------|---------|
| Modbus Instance no/DeviceNet no: | 43262 |
| Profibus slot/index | 169/166 |
| Fieldbus format | UInt |
| Modbus format | UInt |

AnOut2 Advanced [536]

Same functions and submenus as under AnOut1 Advanced [533].

| | |
|---|--|
| 536 AnOut2 Advan Stp A | |
|---|--|

Communication information

| | |
|----------------------------------|---------------------------------------|
| Modbus Instance no/DeviceNet no: | 43263-43267 43546 43556 |
| Profibus slot/index | 169/167-169/171 170/195 170/205 |

11.5.4 Digital Outputs [540]

Submenu with all the settings for the digital outputs.

Digital Out 1 [541]

Sets the function for the digital output 1.

NOTE: The definitions described here are valid for the active output condition.

| 541 DigOut 1 Stp A Ready | | |
|------------------------------------|----|---|
| Default: | | Ready |
| Off | 0 | Output is not active and constantly low. |
| On | 1 | Output is made constantly high, i.e. for checking circuits and trouble shooting. |
| Run | 2 | Running. The AC drive output is active = produces current for the motor. |
| Stop | 3 | The AC drive output is not active. |
| OHZ | 4 | The output frequency=0±0.1Hz when in Run condition. |
| Acc/Dec | 5 | The speed is increasing or decreasing along the acc. ramp dec. ramp. |
| At Process | 6 | The output = Reference. |
| At Max spd | 7 | The frequency is limited by the Maximum Speed. |
| No Trip | 8 | No Trip condition active. |
| Trip | 9 | A Trip condition is active. |
| AutoRst Trip | 10 | Autoreset trip condition active. |
| Limit | 11 | A Limit condition is active. |
| Warning | 12 | A Warning condition is active. |
| Ready | 13 | The AC drive is ready for operation and to accept a start command. This means that the AC drive is powered up and healthy. |
| T= T _{lim} | 14 | The torque is limited by the torque limit function. |
| I>I _{nom} | 15 | The output current is higher than the motor nominal current [224], reduced according to Motor ventilation [228], see Fig. 62. |
| Brake | 16 | The output is used to control a mechanical brake. |
| Sgnl<Offset | 17 | One of the AnIn input signals is lower than 75% of the threshold level. |
| Alarm | 18 | The max or min alarm level has been reached. |
| Pre-Alarm | 19 | The max or min pre alarm level has been reached. |

| | | |
|--------------|----|--|
| Max Alarm | 20 | The max alarm level has been reached. |
| Max PreAlarm | 21 | The max pre alarm level has been reached. |
| Min Alarm | 22 | The min alarm level has been reached. |
| Min PreAlarm | 23 | The min pre alarm Level has been reached. |
| LY | 24 | Logic output Y. |
| !LY | 25 | Logic output Y inverted. |
| LZ | 26 | Logic output Z. |
| !LZ | 27 | Logic output Z inverted. |
| CA 1 | 28 | Analogue comparator 1 output. |
| IA1 | 29 | Analogue comp 1 inverted output. |
| CA 2 | 30 | Analogue comparator 2 output. |
| IA2 | 31 | Analogue comp 2 inverted output. |
| CD 1 | 32 | Digital comparator 1 output. |
| ID1 | 33 | Digital comp 1 inverted output. |
| CD 2 | 34 | Digital comparator 2 output. |
| ID2 | 35 | Digital comp 2 inverted output. |
| Operation | 36 | Run command is active or AC drive running. The signal can be used to control the mains contactor if the AC drive is equipped with Standby supply option. |
| T1Q | 37 | Timer1 output |
| !T1Q | 38 | Timer1 inverted output |
| T2Q | 39 | Timer2 output |
| !T2Q | 40 | Timer2 inverted output |
| Sleeping | 41 | Sleeping function activated |
| Crane Deviat | 42 | Tripped on deviation |
| PumpSlave1 | 43 | Activate pump slave 1 |
| PumpSlave2 | 44 | Activate pump slave 2 |
| PumpSlave3 | 45 | Activate pump slave 3 |
| PumpSlave4 | 46 | Activate pump slave 4 |
| PumpSlave5 | 47 | Activate pump slave 5 |
| PumpSlave6 | 48 | Activate pump slave 6 |
| PumpMaster1 | 49 | Activate pump master 1 |
| PumpMaster2 | 50 | Activate pump master 2 |
| PumpMaster3 | 51 | Activate pump master 3 |
| PumpMaster4 | 52 | Activate pump master 4 |
| PumpMaster5 | 53 | Activate pump master 5 |
| PumpMaster6 | 54 | Activate pump master 6 |
| All Pumps | 55 | All pumps are running |
| Only Master | 56 | Only the master is running |
| Loc/Rem | 57 | Local/Rem function is active |
| Standby | 58 | Standby supply option is active |

| | | |
|--------------|----|---|
| PTC Trip | 59 | Trip when function is active |
| PT100 Trip | 60 | Trip when function is active |
| Overvolt | 61 | Overvoltage due to high main voltage |
| Overvolt G | 62 | Overvoltage due to generation mode |
| Overvolt D | 63 | Overvoltage due to deceleration |
| Acc | 64 | Acceleration along the acc. ramp |
| Dec | 65 | Deceleration along the dec. ramp |
| I^2t | 66 | I^2t limit protection active |
| V-Limit | 67 | Overvoltage limit function active |
| C-Limit | 68 | Overcurrent limit function active |
| Overtemp | 69 | Over temperature warning |
| Low voltage | 70 | Low voltage warning |
| DigIn 1 | 71 | Digital input 1 |
| DigIn 2 | 72 | Digital input 2 |
| DigIn 3 | 73 | Digital input 3 |
| DigIn 4 | 74 | Digital input 4 |
| DigIn 5 | 75 | Digital input 5 |
| DigIn 6 | 76 | Digital input 6 |
| DigIn 7 | 77 | Digital input 7 |
| DigIn 8 | 78 | Digital input 8 |
| ManRst Trip | 79 | Active trip that needs to be manually reset |
| Com Error | 80 | Serial communication lost |
| External Fan | 81 | The AC drive requires external cooling. Internal fans are active. |
| LC Pump | 82 | Activate liquid cooling pump |
| LC HE Fan | 83 | Activate liquid cooling heat exchanger fan |
| LC Level | 84 | Liquid cooling low level signal active |
| Run Right | 85 | Positive speed (>0.5%), i.e. forward/clockwise direction. |
| Run Left | 86 | Negative speed ($\leq 0.5\%$), i.e. reverse counter clockwise direction. |
| Com Active | 87 | Fieldbus communication active. |
| Brk Fault | 88 | Tripped on brake fault (not released) |
| BrkNotEngage | 89 | Warning and continued operation (keep torque) due to Brake not engaged during stop. |
| Option | 90 | Failure occurred in built-in option board. |
| CA3 | 91 | Analogue comparator 3 output |
| !A3 | 92 | Analogue comparator 3 inverted output |
| CA4 | 93 | Analogue comparator 4 output |
| !A4 | 94 | Analogue comparator 4 inverted output |
| CD3 | 95 | Digital comparator 3 output |
| !D3 | 96 | Digital comparator 3 inverted output |

| | | |
|-----|----|--------------------------------------|
| CD4 | 97 | Digital comparator 4 output |
| !D4 | 98 | Digital comparator 4 inverted output |

Communication information

| | |
|----------------------------------|---------|
| Modbus Instance no/DeviceNet no: | 43271 |
| Profibus slot/index | 169/175 |
| Fieldbus format | UInt |
| Modbus format | UInt |

Digital Out 2 [542]

NOTE: The definitions described here are valid for the active output condition.

Sets the function for the digital output 2.

| | |
|--|-----------------------|
| 542 DigOut2 Stp A Brake | |
| Default: | Brake |
| Selection: | Same as in menu [541] |

Communication information

| | |
|----------------------------------|---------|
| Modbus Instance no/DeviceNet no: | 43272 |
| Profibus slot/index | 169/176 |
| Fieldbus format | UInt |
| Modbus format | UInt |

11.5.5 Relays [550]

Submenu with all the settings for the relay outputs. The relay mode selection makes it possible to establish a “fail safe” relay operation by using the normal closed contact to function as the normal open contact.

NOTE: Additional relays will become available when I/O option boards are connected. Maximum 3 boards with 3 relays each.

Relay 1 [551]

Sets the function for the relay output 1. Same function as digital output 1 [541] can be selected.

| | |
|---|-----------------------|
| 551 Relay 1 Stp A Trip | |
| Default: | Trip |
| Selection: | Same as in menu [541] |

Communication information

| | |
|----------------------------------|---------|
| Modbus Instance no/DeviceNet no: | 43273 |
| Profibus slot/index | 169/177 |
| Fieldbus format | UInt |
| Modbus format | UInt |

Relay 2 [552]

NOTE: The definitions described here are valid for the active output condition.

Sets the function for the relay output 2.

| | |
|--|-----------------------|
| 552 Relay 2 Stp A Run | |
| Default: | Run |
| Selection: | Same as in menu [541] |

Communication information

| | |
|----------------------------------|---------|
| Modbus Instance no/DeviceNet no: | 43274 |
| Profibus slot/index | 169/178 |
| Fieldbus format | UInt |
| Modbus format | UInt |

Relay 3 [553]

Sets the function for the relay output 3.

| | |
|--|-----------------------|
| 553 Relay 3 Stp A Off | |
| Default: | Off |
| Selection: | Same as in menu [541] |

Communication information

| | |
|----------------------------------|---------|
| Modbus Instance no/DeviceNet no: | 43275 |
| Profibus slot/index | 169/179 |
| Fieldbus format | UInt |
| Modbus format | UInt |

Board Relay [554] to [55C]

These additional relays are only visible if an I/O option board is fitted in slot 1, 2, or 3. The outputs are named B1 Relay 1–3, B2 Relay 1–3 and B3 Relay 1–3. B stands for board and 1–3 is the number of the board which is related to the position of the I/O option board on the option mounting plate.

NOTE: Visible only if optional board is detected or if any input/output is activated.

Communication information

| | |
|----------------------------------|-----------------|
| Modbus Instance no/DeviceNet no: | 43511–43519 |
| Profibus slot/index | 170/160–170/168 |
| Fieldbus format | UInt |
| Modbus format | UInt |

Relay Advanced [55D]

This function makes it possible to ensure that the relay will also be closed when the AC drive is malfunctioning or powered down.

Example

A process always requires a certain minimum flow. To control the required number of pumps by the relay mode NC, the e.g. the pumps can be controlled normally by the pump control, but are also activated when the AC drive is tripped or powered down.

| |
|--------------------------------------|
| 55D Relay Adv Stp A |
|--------------------------------------|

Relay 1 Mode [55D1]

| | |
|---|--|
| 55D1 Relay Mode Stp A N.O | |
| Default: | N.O |
| N.O | 0 The normal open contact of the relay will be activated when the function is active. |
| N.C | 1 The normally closed contact of the relay will act as a normal open contact. The contact will be opened when function is not active and closed when function is active. |

Communication information

| | |
|----------------------------------|---------|
| Modbus Instance no/DeviceNet no: | 43276 |
| Profibus slot/index | 169/180 |
| Fieldbus format | UInt |
| Modbus format | UInt |

Relay Modes [55D2] to [55DC]

Same function as for relay 1 mode [55D1].

Communication information

| | |
|----------------------------------|-------------------------------------|
| Modbus Instance no/DeviceNet no: | 43277–43278, 43521–43529 |
| Profibus slot/index | 169/181–169/182, 170/170–170/178 |
| Fieldbus format | UInt |
| Modbus format | UInt |

11.5.6 Virtual Connections [560]

Functions to enable eight internal connections of comparator, timer and digital signals, without occupying physical digital in/outputs. Virtual connections are used to wireless connection of a digital output function to a digital input function. Available signals and control functions can be used to create your own specific functions.

Example of start delay

The motor will start in RunR 10 seconds after DigIn1 gets high. DigIn1 has a time delay of 10 s.

| Menu | Parameter | Setting |
|-------|--------------|---------|
| [521] | DigIn1 | Timer 1 |
| [561] | VIO 1 Dest | RunR |
| [562] | VIO 1 Source | T1Q |
| [641] | Timer1 Trig | DigIn 1 |
| [642] | Timer1 Mode | Delay |
| [643] | Timer1 Delay | 0:00:10 |

NOTE: When a digital input and a virtual destination are set to the same function, this function will act as an OR logic function.

Virtual Connection 1 Destination [561]

With this function the destination of the virtual connection is established. When a function can be controlled by several sources, e.g. VC destination or Digital Input, the function will be controlled in conformity with “OR logic”. See DigIn for descriptions of the different selections.

| | |
|--|---|
| 561 VIO 1 Dest Stp A off | |
| Default: | Off |
| Selection: | Same selections as for Digital Input 1, menu [521]. |

Communication information

| | |
|----------------------------------|---------|
| Modbus Instance no/DeviceNet no: | 43281 |
| Profibus slot/index | 169/185 |
| Fieldbus format | UInt |
| Modbus format | UInt |

Virtual Connection 1 Source [562]

With this function the source of the virtual connection is defined. See DigOut 1 for description of the different selections.

| | |
|-------------------------|-------------------------|
| 562 VIO 1 Source | |
| Stp A Off | |
| Default: | Off |
| Selection: | Same as for menu [541]. |

Communication information

| | |
|----------------------------------|---------|
| Modbus Instance no/DeviceNet no: | 43282 |
| Profibus slot/index | 169/186 |
| Fieldbus format | UInt |
| Modbus format | UInt |

Virtual Connections 2-8 [563] to [56G]

Same function as virtual connection 1 [561] and [562].

Communication information for virtual connections 2-8 Destination.

| | |
|----------------------------------|---|
| Modbus Instance no/DeviceNet no: | 43283, 43285, 43287, 43289, 43291, 43293, 43295 |
| Profibus slot/index | 169/ 187, 189, 191, 193, 195, 197, 199 |
| Fieldbus format | UInt |
| Modbus format | UInt |

Communication information for virtual connections 2-8 Source.

| | |
|----------------------------------|---|
| Modbus Instance no/DeviceNet no: | 43284, 43286, 43288, 43290, 43292, 43294, 43296 |
| Profibus slot/index | 169/ 188, 190, 192, 194, 196, 198, 200 |
| Fieldbus format | UInt |
| Modbus format | UInt |

11.6 Logical Functions and Timers [600]

With the Comparators, Logic Functions and Timers, conditional signals can be programmed for control or signalling features. This gives you the ability to compare different signals and values in order to generate monitoring/controlling features.

11.6.1 Comparators [610]

The comparators available make it possible to monitor different internal signals and values, and visualize via digital relay outputs, when a specific value or status is reached or established.

Analogue comparators [611] - [614]

There are 4 analogue comparators that compare any available analogue value (including the analogue reference inputs) with two adjustable levels. The two levels available are Level HI and Level LO. There are two analogue comparator types selectable, an analogue comparator with hysteresis and an analogue window comparator.

The analogue hysteresis type comparator uses the two available levels to create a hysteresis for the comparator between setting and resetting the output. This function gives a clear difference in switching levels, which lets the process adapt until a certain action is started. With such a hysteresis, even an unstable analogue signal can be monitored without getting a nervous comparator output signal. Another feature is the possibility to get a fixed indication that a certain level has been passed. The comparator can latch by setting Level LO to a higher value than Level HI.

The analogue window comparator uses the two available levels to define the window in which the analogue value should be within for setting the comparator output.

The input analogue value of the comparator can also be selected as bipolar, i.e. treated as signed value or unipolar, i.e. treated as absolute value.

Refer to Fig. 103, page 141 where these functions are illustrated.

Digital comparators [615]

There are 4 digital comparators that compare any available digital signal.

The output signals of these comparators can be logically tied together to yield a logical output signal.

All the output signals can be programmed to the digital or relay outputs or used as a source for the virtual connections [560].

CA1 Setup [611]

Analogue comparator 1, parameter group.

Analogue Comparator 1, Value [6111]

Selection of the analogue value for Analogue Comparator 1 (CA1).

Analogue comparator 1 compares the selectable analogue value in menu [6111] with the constant Level HI in menu [6112] and constant Level LO in menu [6113]. If Bipolar type [6115] input signal is selected then the comparison is made with sign otherwise if unipolar selected then comparison is made with absolute values.

For Hysteresis comparator type [6114], when the value exceeds the upper limit level high, the output signal CA1 is set high and !A1 low, see Fig. 99. When the value decreases below the lower limit, the output signal CA1 is set low and !A1 high.

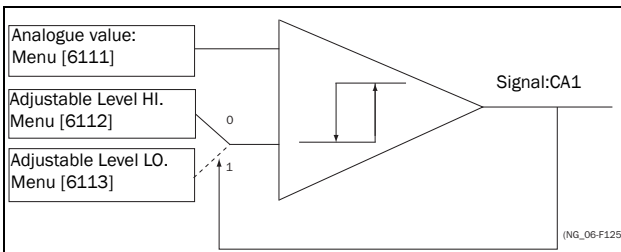

Fig. 99 Analogue comparator type Hysteresis

For Window comparator type [6114], when the value is between the lower and upper levels, the output signal value CA1 is set high and !A1 low, see Fig 113. When the value is outside the band of lower and upper levels, the output CA1 is set low and !A1 high.

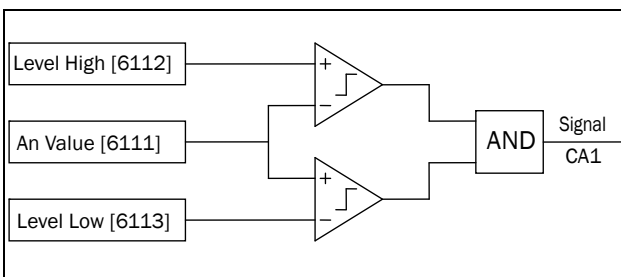

Fig. 100 Analogue comparator type "Window"

The output signal can be programmed as a virtual connection source and to the digital or relay outputs.

| 6111 CA1 Value | | |
|------------------------------|----|---|
| Stp_A Speed | | |
| Default: | | Speed |
| Process Val | 0 | Set by Process settings [321] and [322] |
| Speed | 1 | rpm |
| Torque | 2 | % |
| Shaft Power | 3 | kW |
| EI Power | 4 | kW |
| Current | 5 | A |
| Output Volt | 6 | V |
| Frequency | 7 | Hz |
| DC Voltage | 8 | V |
| Heatsink Tmp | 9 | °C |
| PT100_1 | 10 | °C |
| PT100_2 | 11 | °C |
| PT100_3 | 12 | °C |
| Energy | 13 | kWh |
| Run Time | 14 | h |
| Mains Time | 15 | h |
| AnIn1 | 16 | % |
| AnIn2 | 17 | % |
| AnIn3 | 18 | % |
| AnIn4 | 19 | % |
| Process Ref | 20 | Set by Process settings [321] and [322] |
| Process Err | 21 | |

Communication information

| | |
|----------------------------------|--------|
| Modbus Instance no/DeviceNet no: | 43401 |
| Profibus slot/index | 170/50 |
| Fieldbus format | UInt |
| Modbus format | UInt |

Example

Create automatic RUN/STOP signal via the analogue reference signal. Analogue current reference signal, 4-20 mA, is connected to Analogue Input 1. AnIn1 Setup, menu [512] = 4-20 mA and the threshold is 4 mA. Full scale (100%) input signal on AnIn 1 = 20 mA. When the reference signal on AnIn1 increases 80% of the threshold ($4 \text{ mA} \times 0.8 = 3.2 \text{ mA}$), the AC drive will be set in RUN mode. When the signal on AnIn1 goes below 60% of the threshold ($4 \text{ mA} \times 0.6 = 2.4 \text{ mA}$) the AC drive is set to STOP mode. The output of CA1 is used as a virtual connection source that controls the virtual connection destination RUN.

| Menu | Function | Setting |
|------|----------------|---|
| 511 | AnIn1 Function | Process reference |
| 512 | AnIn1 Set-up | 4-20 mA, threshold is 4 mA |
| 341 | Min Speed | 0 |
| 343 | Max Speed | 1500 |
| 6111 | CA1 Value | AnIn1 |
| 6112 | CA1 Level HI | 16% ($3.2\text{mA}/20\text{mA} \times 100\%$) |
| 6113 | CA1 Level LO | 12% ($2.4\text{mA}/20\text{mA} \times 100\%$) |
| 6114 | CA1 Type | Hysteresis |
| 561 | VIO 1 Dest | RunR |
| 562 | VIO 1 Source | CA1 |
| 215 | Run/Stp Ctrl | Remote |

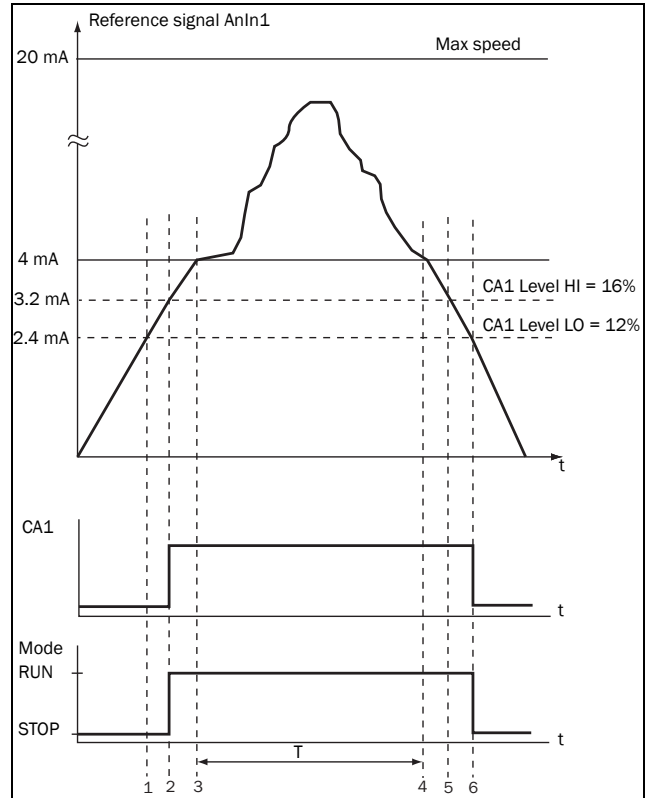

Fig. 101

| No. | Description |
|-----|---|
| 1 | The reference signal passes the Level LO value from below (positive edge), the comparator CA1 output stays low, mode=RUN. |
| 2 | The reference signal passes the Level HI value from below (positive edge), the comparator CA1 output is set high, mode=RUN. |
| 3 | The reference signal passes the threshold level of 4 mA, the motor speed will now follow the reference signal. |
| T | During this period the motor speed will follow the reference signal. |
| 4 | The reference signal reaches the threshold level, motor speed is 0 rpm, mode = RUN. |
| 5 | The reference signal passes the Level HI value from above (negative edge), the comparator CA1 output stays high, mode =RUN. |
| 6 | The reference signal passes the Level LO value from above (negative edge), the comparator CA1 output=STOP. |

Analogue Comparator 1, Level High [6112]

Sets the analogue comparator high level, with range according to the selected value in menu [6111].

| | |
|--|-----------------------------|
| 6112 CA1 Level HI StpA 300rpm | |
| Default: | 300 rpm |
| Range: | See min/max in table below. |

Min/Max setting range for menu [6112]

| Mode | Min | Max | Decimals |
|-------------------|---|-------------------------|----------|
| Process Val | Set by Process settings [321] and [322] | | 3 |
| Speed, rpm | 0 | Max speed | 0 |
| Torque, % | 0 | Max torque | 0 |
| Shaft Power, kW | 0 | Motor P _n x4 | 0 |
| El Power, kW | 0 | Motor P _n x4 | 0 |
| Current, A | 0 | Motor I _n x4 | 1 |
| Output volt, V | 0 | 1000 | 1 |
| Frequency, Hz | 0 | 400 | 1 |
| DC voltage, V | 0 | 1250 | 1 |
| Heatsink temp, °C | 0 | 100 | 1 |
| PT 100_1_2_3, °C | -100 | 300 | 1 |
| Energy, kWh | 0 | 1000000 | 0 |
| Run time, h | 0 | 65535 | 0 |
| Mains time, h | 0 | 65535 | 0 |
| AnIn 1-4% | 0 | 100 | 0 |
| Process Ref | Set by Process settings [321] and [322] | | 3 |
| Process Err | Set by Process settings [321] and [322] | | 3 |

NOTE: If Bipolar selected [6115] then Min value is equal to -Max in the table.

Communication information

| | |
|----------------------------------|---|
| Modbus Instance no/DeviceNet no: | 43402 |
| Profibus slot/index | 170/51 |
| Fieldbus format | Long, 1=1 W, 0.1 A, 0.1 V, 0.1 Hz, 0.1°C, 1 kWh, 1H, 1%, 1 rpm or 0.001 via process value |
| Modbus format | Elnt |

Example

This example describes, both for hysteresis and window type comparator, the normal use of the constant level high and low.

| Menu | Function | Setting |
|------|--------------|------------|
| 343 | Max Speed | 1500 |
| 6111 | CA1 Value | Speed |
| 6112 | CA1 Level HI | 300 rpm |
| 6113 | CA1 Level LO | 200 rpm |
| 6114 | CA1 Type | Hysteresis |
| 561 | VC1 Dest | Timer 1 |
| 562 | VC1 Source | CA1 |

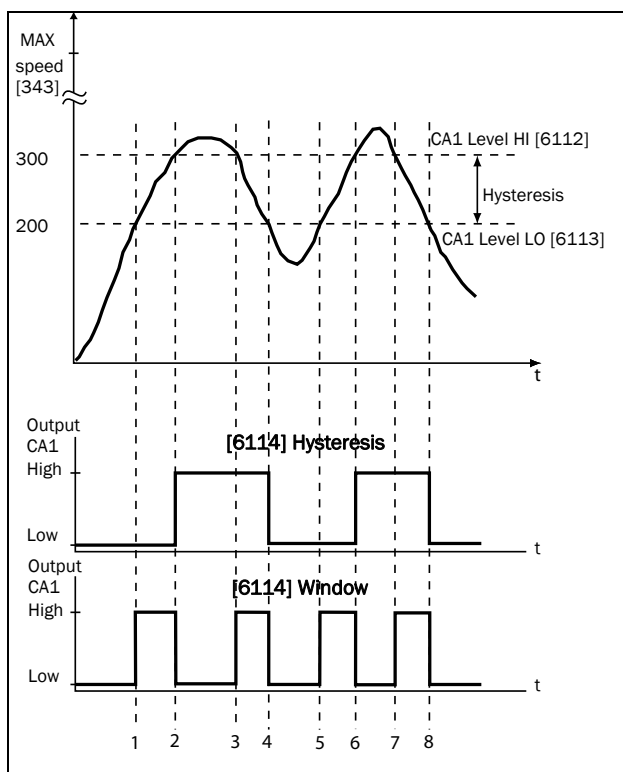

Fig. 102

| No. | Description | Hysteresis | Window |
|-----|---|------------|--------|
| 1 | The reference signal passes the Level LO value from below (positive edge), the comparator CA1 does not change, output stays low. | — | ↑ |
| 2 | The reference signal passes the Level HI value from below (positive edge), the comparator CA1 output is set high. | ↑ | ↓ |
| 3 | The reference signal passes the Level HI value from above (negative edge), the comparator CA1 does not change, output stays high. | — | ↑ |
| 4 | The reference signal passes the Level LO value from above (negative edge), the comparator CA1 is reset, output is set low. | ↓ | ↓ |
| 5 | The reference signal passes the Level LO value from below (positive edge), the comparator CA1 does not change, output stays low. | — | ↑ |
| 6 | The reference signal passes the Level HI value from below (positive edge), the comparator CA1 output is set high. | ↑ | ↓ |
| 7 | The reference signal passes the Level HI value from above (negative edge), the comparator CA1 does not change, output stays high. | — | ↑ |
| 8 | The reference signal passes the Level LO value from above (negative edge), the comparator CA1 is reset, output is set low. | ↓ | ↓ |

Analogue Comparator 1, Level Low [6113]

Sets the analogue comparator low level, with unit and range according to the selected value in menu [6111].

| | |
|--|------------------|
| 6113 CA1 Level LO StpA 200rpm | |
| Default: | 200 rpm |
| Range: | Range as [6112]. |

Communication information

| | |
|----------------------------------|---|
| Modbus Instance no/DeviceNet no: | 43403 |
| Profibus slot/index | 170/52 |
| Fieldbus format | Long, 1=1 W, 0.1 A, 0.1 V, 0.1 Hz, 0.1°C, 1 kWh, 1H, 1%, 1 rpm or 0.001 via process value |
| Modbus format | Elnt |

Analogue Comparator 1, Type [6114]

Selects the analogue comparator type, i.e. Hysteresis or Window type. See Fig. 103 and Fig. 104.

| | |
|--|------------------------------|
| 6114 CA1 Type StpA Hysteresis | |
| Default: | Hysteresis |
| Hysteresis | 0 Hysteresis type comparator |
| Window | 1 Window type comparator |

Communication information

| | |
|----------------------------------|---|
| Modbus Instance no/DeviceNet no: | 43481 |
| Profibus slot/index | 170/130 |
| Fieldbus format | Long, 1=1 W, 0.1 A, 0.1 V, 0.1 Hz, 0.1°C, 1 kWh, 1H, 1%, 1 rpm or 0.001 via process value |
| Modbus format | Elnt |

Analogue Comparator 1, Polarity [6115]

Selects how the selected value in [6111] should be handled prior to the the analogue comparator , i.e. as absolute value or handled with sign. See Fig. 103

| | |
|---|---------------------------------|
| 6115 CA1 Polar StpA Unipolar | |
| Default: | Unipolar |
| Unipolar | 0 Absolute value of [6111] used |
| Bipolar | 1 Signed value of [6111] used |

Communication information

| | |
|----------------------------------|---|
| Modbus Instance no/DeviceNet no: | 43486 |
| Profibus slot/index | 170/135 |
| Fieldbus format | Long, 1=1 W, 0.1 A, 0.1 V, 0.1 Hz, 0.1°C, 1 kWh, 1H, 1%, 1 rpm or 0.001 via process value |
| Modbus format | Elnt |

Example

See Fig. 103 and Fig. 104 for different principle functionality of comparator features 6114 and 6115.

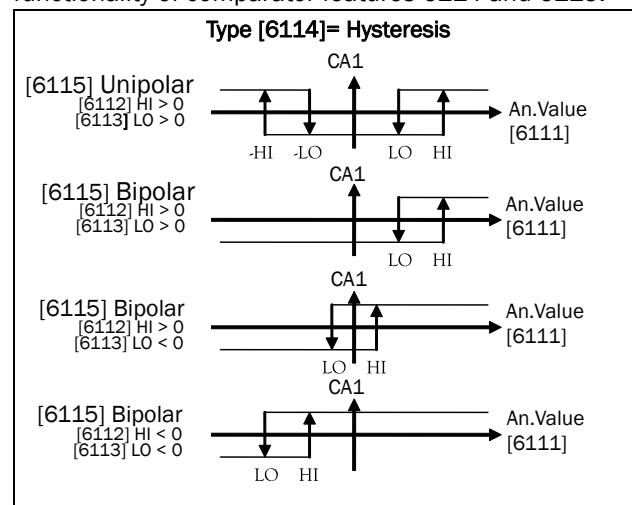

Fig. 103 Principle functionality of comparator features for "Type [6114] = Hysteresis" and "Polar [6115]".

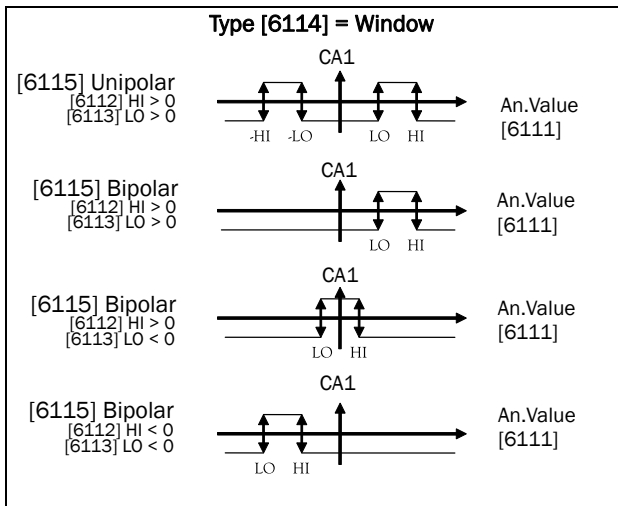

Fig. 104 Principle functionality of comparator features for “Type [6114] = Window” and “Polar [6115]”.

NOTE: When “Unipolar” is selected, absolute value of signal is used.

NOTE: When “Bipolar” is selected in [6115] then:
1. Functionality is not symmetrical and
2. Ranges for high/low are bipolar

CA2 Setup [612]

Analogue comparator 2, parameter group.

Analogue Comparator 2, Value [6121]

Function is identical to analogue comparator 1, value [6111].

| | |
|---|------------------------|
| 6121 CA2 Value StpA Torque | |
| Default: | Torque |
| Selections: | Same as in menu [6111] |

Communication information

| | |
|----------------------------------|--------|
| Modbus Instance no/DeviceNet no: | 43404 |
| Profibus slot/index | 170/53 |
| Fieldbus format | UInt |
| Modbus format | UInt |

Analogue Comparator 2, Level High [6122]

Function is identical to analogue comparator 1, level high [6112].

| | |
|---|-----------------------------------|
| 6122 CA2 Level HI StpA 20% | |
| Default: | 20% |
| Range: | Enter a value for the high level. |

Communication information

| | |
|----------------------------------|--|
| Modbus Instance no/DeviceNet no: | 43405 |
| Profibus slot/index | 170/54 |
| Fieldbus format | Long 1=1 W, 0.1 A, 0.1 V, 0.1 Hz, 0.1°C, 1 kWh, 1H, 1%, 1 rpm or 0.001 via process value |
| Modbus format | EInt |

Analogue Comparator 2, Level Low [6123]

Function is identical to analogue comparator 1, level low [6113].

| | |
|---|----------------------------------|
| 6123 CA2 Level LO StpA 10% | |
| Default: | 10% |
| Range: | Enter a value for the low level. |

Communication information

| | |
|----------------------------------|---|
| Modbus Instance no/DeviceNet no: | 43406 |
| Profibus slot/index | 170/55 |
| Fieldbus format | Long, 1=1 W, 0.1 A, 0.1 V, 0.1 Hz, 0.1°C, 1 kWh, 1H, 1%, 1 rpm or 0.001 via process value |
| Modbus format | EInt |

Analogue Comparator 2, Type [6124]

Function is identical to analogue comparator 1, Type [6114].

| | | |
|------------|---|---|
| | | 6124 CA2 Type Stp_A Hysteresis |
| Default: | | Hysteresis |
| Hysteresis | 0 | Hysteresis type comparator |
| Window | 1 | Window type comparator |

Communication information

| | |
|----------------------------------|---|
| Modbus Instance no/DeviceNet no: | 43482 |
| Profibus slot/index | 170/131 |
| Fieldbus format | Long, 1=1 W, 0.1 A, 0.1 V, 0.1 Hz, 0.1°C, 1 kWh, 1H, 1%, 1 rpm or 0.001 via process value |
| Modbus format | Elnt |

Analogue Comparator 2, Polar [6125]

Function is identical to analogue comparator 1, Polar [6115].

| | | |
|----------|---|--|
| | | 6125 CA2 Polar Stp_A Unipolar |
| Default: | | Unipolar |
| Unipolar | 0 | Absolute value of [6111] used |
| Bipolar | 1 | Signed value of [6111] used |

Communication information

| | |
|----------------------------------|---|
| Modbus Instance no/DeviceNet no: | 43487 |
| Profibus slot/index | 170/136 |
| Fieldbus format | Long, 1=1 W, 0.1 A, 0.1 V, 0.1 Hz, 0.1°C, 1 kWh, 1H, 1%, 1 rpm or 0.001 via process value |
| Modbus format | Elnt |

CA3 Setup [613]

Analogue comparators 3, parameter group.

Analogue Comparator 3, Value [6131]

Function is identical to analogue comparator 1, value [6111]

| | | |
|-------------|--|---|
| | | 6131 CA3 Value Stp_A Process Val |
| Default: | | Process Value |
| Selections: | | Same as in menu [6111] |

Communication information

| | |
|----------------------------------|---------|
| Modbus Instance no/DeviceNet no: | 43471 |
| Profibus slot/index | 170/120 |
| Fieldbus format | UInt |
| Modbus format | UInt |

Analogue Comparator 3, Level High [6132]

Function is identical to analogue comparator 1, level high [6112].

| | | |
|----------|--|---|
| | | 6132 CA3 Level HI Stp_A 300rpm |
| Default: | | 300rpm |
| Range: | | Enter a value for the high level. |

Communication information

| | |
|----------------------------------|--|
| Modbus Instance no/DeviceNet no: | 43472 |
| Profibus slot/index | 170/121 |
| Fieldbus format | Long 1=1 W, 0.1 A, 0.1 V, 0.1 Hz, 0.1°C, 1 kWh, 1H, 1%, 1 rpm or 0.001 via process value |
| Modbus format | Elnt |

Analogue Comparator 3, Level Low [6133]

Function is identical to analogue comparator 1,
level low [6113].

| | |
|--|----------------------------------|
| 6133 CA3 Level LO StpA 200rpm | |
| Default: | 200 rpm |
| Range: | Enter a value for the low level. |

Communication information

| | |
|----------------------------------|---|
| Modbus Instance no/DeviceNet no: | 43473 |
| Profibus slot/index | 170/122 |
| Fieldbus format | Long, 1=1 W, 0.1 A, 0.1 V, 0.1 Hz, 0.1°C, 1 kWh, 1H, 1%, 1 rpm or 0.001 via process value |
| Modbus format | Elnt |

Analogue Comparator, 3 Type [6134]

Function is identical to analogue comparator 1, level
Type [6114]

| | |
|--|------------------------------|
| 6134 CA3 Type StpA Hysteresis | |
| Default: | Hysteresis |
| Hysteresis | 0 Hysteresis type comparator |
| Window | 1 Window type comparator |

Communication information

| | |
|----------------------------------|---|
| Modbus Instance no/DeviceNet no: | 43483 |
| Profibus slot/index | 170/132 |
| Fieldbus format | Long, 1=1 W, 0.1 A, 0.1 V, 0.1 Hz, 0.1°C, 1 kWh, 1H, 1%, 1 rpm or 0.001 via process value |
| Modbus format | Elnt |

Analogue Comparator 3, Polar [6135]

Function is identical to analogue comparator 1,
Polar [6115].

| | |
|---|---------------------------------|
| 6135 CA3 Polar StpA Unipolar | |
| Default: | Unipolar |
| Unipolar | 0 Absolute value of [6111] used |
| Bipolar | 1 Signed value of [6111] used |

Communication information

| | |
|----------------------------------|---|
| Modbus Instance no/DeviceNet no: | 43488 |
| Profibus slot/index | 170/137 |
| Fieldbus format | Long, 1=1 W, 0.1 A, 0.1 V, 0.1 Hz, 0.1°C, 1 kWh, 1H, 1%, 1 rpm or 0.001 via process value |
| Modbus format | Elnt |

CA4 Setup [614]

Analogue comparators 4, parameter group.

Analogue Comparator 4, Value [6141]

Function is identical to analogue comparator 1,
value [6111].

| | |
|--|------------------------|
| 6141 CA4 Value StpA Process Err | |
| Default: | Process Error |
| Selections: | Same as in menu [6111] |

Communication information

| | |
|----------------------------------|---------|
| Modbus Instance no/DeviceNet no: | 43474 |
| Profibus slot/index | 170/123 |
| Fieldbus format | UInt |
| Modbus format | UInt |

Analogue Comparator 4, Level High [6142]

Function is identical to analogue comparator 1 level high [6112].

| | |
|--|-----------------------------------|
| 6142 CA4 Level HI StpA 100rpm | |
| Default: | 100rpm |
| Range: | Enter a value for the high level. |

Communication information

| | |
|----------------------------------|--|
| Modbus Instance no/DeviceNet no: | 43475 |
| Profibus slot/index | 170/124 |
| Fieldbus format | Long 1=1 W, 0.1 A, 0.1 V, 0.1 Hz, 0.1°C, 1 kWh, 1H, 1%, 1 rpm or 0.001 via process value |
| Modbus format | Elnt |

Analogue Comparator 4, Level Low [6143]

Function is identical to analogue comparator 1, level low [6113].

| | |
|---|----------------------------------|
| 6143 CA4 Level LO StpA -100rpm | |
| Default: | -100 rpm |
| Range: | Enter a value for the low level. |

Communication information

| | |
|----------------------------------|---|
| Modbus Instance no/DeviceNet no: | 43476 |
| Profibus slot/index | 170/125 |
| Fieldbus format | Long, 1=1 W, 0.1 A, 0.1 V, 0.1 Hz, 0.1°C, 1 kWh, 1H, 1%, 1 rpm or 0.001 via process value |
| Modbus format | Elnt |

Analogue Comparator 4, Type [6144]

Function is identical to analogue comparator 1, level Type [6114]

| | | |
|--------------------------------------|---|----------------------------|
| 6144 CA4 Type StpA Window | | |
| Default: | | Window |
| Hysteresis | 0 | Hysteresis type comparator |
| Window | 1 | Window type comparator |

Communication information

| | |
|----------------------------------|---|
| Modbus Instance no/DeviceNet no: | 43484 |
| Profibus slot/index | 170/133 |
| Fieldbus format | Long, 1=1 W, 0.1 A, 0.1 V, 0.1 Hz, 0.1°C, 1 kWh, 1H, 1%, 1 rpm or 0.001 via process value |
| Modbus format | Elnt |

Analogue Comparator 4, Polar [6145]

Function is identical to analogue comparator 1, Polar [6115]

| | | |
|--|---|-------------------------------|
| 6145 CA4 Polar StpA Bipolar | | |
| Default: | | Bipolar |
| Unipolar | 0 | Absolute value of [6111] used |
| Bipolar | 1 | Signed value of [6111] used |

Communication information

| | |
|----------------------------------|---|
| Modbus Instance no/DeviceNet no: | 43489 |
| Profibus slot/index | 170/138 |
| Fieldbus format | Long, 1=1 W, 0.1 A, 0.1 V, 0.1 Hz, 0.1°C, 1 kWh, 1H, 1%, 1 rpm or 0.001 via process value |
| Modbus format | Elnt |

Digital comparator Setup [615]

Digital comparators, parameter group.

Digital Comparator 1 [6151]

Selection of the input signal for digital comparator 1 (CD1).

The output signal CD1 is set high if the selected input signal is active. See Fig. 105.

The output signal can be programmed to the digital or relay outputs or used as a source for the virtual connections [560].

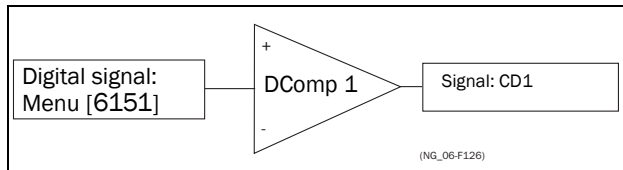

Fig. 105 Digital comparator

| | |
|---|--|
| 6151 CD1 StpA Run | |
| Default: | Run |
| Selection: | Same selections as for DigOut 1 [541]. |

Communication information

| | |
|----------------------------------|--------|
| Modbus Instance no/DeviceNet no: | 43407 |
| Profibus slot/index | 170/56 |
| Fieldbus format | UInt |
| Modbus format | UInt |

Digital Comparator 2 [6152]

Function is identical to digital comparator 1 [6151].

| | |
|--|--|
| 6152 CD 2 StpA DigIn 1 | |
| Default: | DigIn 1 |
| Selection: | Same selections as for DigOut 1 [541]. |

Communication information

| | |
|----------------------------------|--------|
| Modbus Instance no/DeviceNet no: | 43408 |
| Profibus slot/index | 170/57 |
| Fieldbus format | UInt |
| Modbus format | UInt |

Digital Comparator 3 [6153]

Function is identical to digital comparator 1 [6151].

| | |
|---|--|
| 6153 CD 3 StpA Trip | |
| Default: | Trip |
| Selection: | Same selections as for DigOut 1 [541]. |

Communication information

| | |
|----------------------------------|---------|
| Modbus Instance no/DeviceNet no: | 43477 |
| Profibus slot/index | 170/126 |
| Fieldbus format | UInt |
| Modbus format | UInt |

Digital Comparator 4 [6154]

Function is identical to digital comparator 1 [6151].

| | |
|--|--|
| 6154 CD 4 StpA Ready | |
| Default: | Ready |
| Selection: | Same selections as for DigOut 1 [541]. |

Communication information

| | |
|----------------------------------|---------|
| Modbus Instance no/DeviceNet no: | 43478 |
| Profibus slot/index | 170/127 |
| Fieldbus format | UInt |
| Modbus format | UInt |

11.6.2 Logic Output Y [620]

By means of an expression editor, the comparator signals can be logically combined into the Logic Y function.

The expression editor has the following features:

- The following signals can be used:
CA1, CA2, CD1, CD2 or LZ (or LY)
- The following signals can be inverted:
!A1, !A2, !D1, !D2, or !LZ (or !LY)
- The following logical operators are available:
"+" : OR operator
"&" : AND operator
"^" : EXOR operator

Expressions according to the following truth table can be made:

| Input | | Result | | |
|-------|---|---------|--------|---------|
| A | B | & (AND) | + (OR) | ^(EXOR) |
| 0 | 0 | 0 | 0 | 0 |
| 0 | 1 | 0 | 1 | 1 |
| 1 | 0 | 0 | 1 | 1 |
| 1 | 1 | 1 | 1 | 0 |

The output signal can be programmed to the digital or relay outputs or used as a Virtual Connection Source [560].

```
620 LOGIC Y
Stp CA1&!A2&CD1
```

Communication information

| | |
|----------------------------------|---------|
| Modbus Instance no/DeviceNet no: | 31035 |
| Profibus slot/index | 121/179 |
| Fieldbus format | Long |
| Modbus format | Text |

The expression must be programmed by means of the menus [621] to [625].

Example:

Broken belt detection for Logic Y

This example describes the programming for a so-called "broken belt detection" for fan applications.

The comparator CA1 is set for frequency > 10Hz.

The comparator !A2 is set for load < 20%.

The comparator CD1 is set for Run.

The 3 comparators are all AND-ed, given the "broken belt detection".

In menus [621]-[625] expression entered for Logic Y is visible.

Set menu [621] to CA1

Set menu [622] to &

Set menu [623] to !A2

Set menu [624] to &

Set menu [625] to CD1

Menu [620] now holds the expression for Logic Y:

CA1&!A2&CD1

which is to be read as:

(CA1&!A2)&CD1

NOTE: Set menu [624] to "." to finish the expression when only two comparators are required for Logic Y.

Y Comp 1 [621]

Selects the first comparator for the logic Y function.

| <div style="border: 2px solid black; padding: 2px; display: inline-block;"> 621 Y Comp 1 Stp A CA1 </div> | | |
|--|-----|--|
| Default: | CA1 | |
| CA1 | 0 | |
| IA1 | 1 | |
| CA2 | 2 | |
| IA2 | 3 | |
| CD1 | 4 | |
| !D1 | 5 | |
| CD2 | 6 | |
| !D2 | 7 | |
| LZ/LY | 8 | |
| !LZ/!LY | 9 | |
| T1 | 10 | |
| !T1 | 11 | |
| T2 | 12 | |
| !T2 | 13 | |
| CA3 | 14 | |
| IA3 | 15 | |
| CA4 | 16 | |
| IA4 | 17 | |
| CD3 | 18 | |
| !D3 | 19 | |
| CD4 | 20 | |
| !D4 | 21 | |

Communication information

| | |
|----------------------------------|--------|
| Modbus Instance no/DeviceNet no: | 43411 |
| Profibus slot/index | 170/60 |
| Fieldbus format | UInt |
| Modbus format | UInt |

Y Operator 1 [622]

Selects the first operator for the logic Y function.

| <div style="border: 2px solid black; padding: 2px; display: inline-block;"> 622 Y Operator 1 Stp A & </div> | | |
|--|---|--------|
| Default: | & | |
| & | 1 | &=AND |
| + | 2 | +=OR |
| ^ | 3 | ^=EXOR |

Communication information

| | |
|----------------------------------|--------|
| Modbus Instance no/DeviceNet no: | 43412 |
| Profibus slot/index | 170/61 |
| Fieldbus format | UInt |
| Modbus format | UInt |

Y Comp 2 [623]

Selects the second comparator for the logic Y function.

| <div style="border: 2px solid black; padding: 2px; display: inline-block;"> 623 Y Comp 2 Stp A !A2 </div> | |
|--|--------------------|
| Default: | !A2 |
| Selection: | Same as menu [621] |

Communication information

| | |
|----------------------------------|--------|
| Modbus Instance no/DeviceNet no: | 43413 |
| Profibus slot/index | 170/62 |
| Fieldbus format | UInt |
| Modbus format | UInt |

Y Operator 2 [624]

Selects the second operator for the logic Y function.

| | | |
|---|---|---|
| 624 Y Operator 2 Stp A & | | |
| Default: | & | |
| . | 0 | When · (dot) is selected, the Logic Y expression is finished (when only two expressions are tied together). |
| & | 1 | &=AND |
| + | 2 | + =OR |
| ^ | 3 | ^=EXOR |

Communication information

| | |
|----------------------------------|--------|
| Modbus Instance no/DeviceNet no: | 43414 |
| Profibus slot/index | 170/63 |
| Fieldbus format | UInt |
| Modbus format | UInt |

Y Comp 3 [625]

Selects the third comparator for the logic Y function.

| | |
|---|--------------------|
| 625 Y Comp 3 Stp A CD1 | |
| Default: | CD1 |
| Selection: | Same as menu [621] |

Communication information

| | |
|----------------------------------|--------|
| Modbus Instance no/DeviceNet no: | 43415 |
| Profibus slot/index | 170/64 |
| Fieldbus format | UInt |
| Modbus format | UInt |

11.6.3 Logic Output Z [630]

630 LOGIC Z
Stp **A** CA1&!A2&CD1

The expression must be programmed by means of the menus [631] to [635].

Z Comp 1 [631]

Selects the first comparator for the logic Z function.

| | |
|---|--------------------|
| 631 Z Comp 1 Stp A CA1 | |
| Default: | CA1 |
| Selection: | Same as menu [621] |

Communication information

| | |
|----------------------------------|--------|
| Modbus Instance no/DeviceNet no: | 43421 |
| Profibus slot/index | 170/70 |
| Fieldbus format | UInt |
| Modbus format | UInt |

Z Operator 1 [632]

Selects the first operator for the logic Z function.

| | |
|---|--------------------|
| 632 Z Operator 1 Stp A & | |
| Default: | & |
| Selection: | Same as menu [622] |

Communication information

| | |
|----------------------------------|--------|
| Modbus Instance no/DeviceNet no: | 43422 |
| Profibus slot/index | 170/71 |
| Fieldbus format | UInt |
| Modbus format | UInt |

Z Comp 2 [633]

Selects the second comparator for the logic Z function.

| | |
|---|--------------------|
| 633 Z Comp 2 Stp A !A2 | |
| Default: | !A2 |
| Selection: | Same as menu [621] |

Communication information

| | |
|----------------------------------|--------|
| Modbus Instance no/DeviceNet no: | 43423 |
| Profibus slot/index | 170/72 |
| Fieldbus format | UInt |
| Modbus format | UInt |

Z Operator 2 [634]

Selects the second operator for the logic Z function.

| | |
|---|--------------------|
| 634 Z Operator 2 Stp A & | |
| Default: | & |
| Selection: | Same as menu [624] |

Communication information

| | |
|----------------------------------|--------|
| Modbus Instance no/DeviceNet no: | 43424 |
| Profibus slot/index | 170/73 |
| Fieldbus format | UInt |
| Modbus format | UInt |

Z Comp 3 [635]

Selects the third comparator for the logic Z function.

| | |
|---|--------------------|
| 635 Z Comp 3 Stp A CD1 | |
| Default: | CD1 |
| Selection: | Same as menu [621] |

Communication information

| | |
|----------------------------------|--------|
| Modbus Instance no/DeviceNet no: | 43425 |
| Profibus slot/index | 170/74 |
| Fieldbus format | UInt |
| Modbus format | UInt |

11.6.4 Timer1 [640]

The Timer functions can be used as a delay timer or as an interval with separate On and Off times (alternate

mode). In delay mode, the output signal T1Q becomes high if the set delay time is expired. See Fig. 106.

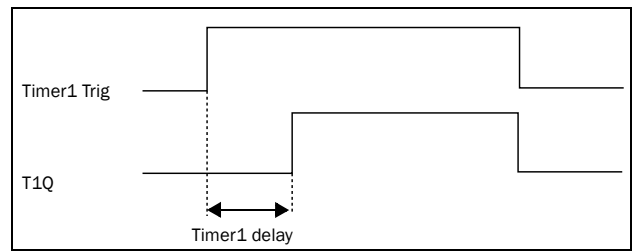

Fig. 106

In alternate mode, the output signal T1Q will switch automatically from high to low etc. according to the set interval times. See Fig. 107.

The output signal can be programmed to the digital or relay outputs used in logic functions [620] and [630], or as a virtual connection source [560].

NOTE: The actual timers are common for all parameter sets. If the actual set is changed, the timer functionality [641] to [645] will change according set settings but the timer value will stay unchanged. So initialization of the timer might differ for a set change compared to normal triggering of a timer.

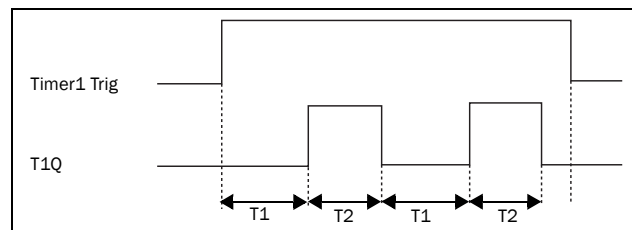

Fig. 107

Timer 1 Trig [641]

| | |
|--|---|
| 641 Timer1 Trig Stp A Off | |
| Default: | Off |
| Selection: | Same selections as Digital Output 1 menu [541]. |

Communication information

| | |
|----------------------------------|--------|
| Modbus Instance no/DeviceNet no: | 43431 |
| Profibus slot/index | 170/80 |
| Fieldbus format | UInt |
| Modbus format | UInt |

Timer 1 Mode [642]

| | |
|--|-----|
| 642 Timer1 Mode Stp A Off | |
| Default: | Off |
| Off | 0 |
| Delay | 1 |
| Alternate | 2 |

Communication information

| | |
|----------------------------------|--------|
| Modbus Instance no/DeviceNet no: | 43432 |
| Profibus slot/index | 170/81 |
| Fieldbus format | UInt |
| Modbus format | UInt |

Timer 1 Delay [643]

This menu is only visible when timer mode is set to delay.

This menu can only be edited as in alternative 2, see section 9.5, page 57.

Timer 1 delay sets the time that will be used by the first timer after it is activated. Timer 1 can be activated by a high signal on a DigIn that is set to Timer 1 or via a virtual destination [560].

| | |
|--|----------------------|
| 643 Timer1Delay Stp A 0:00:00 | |
| Default: | 0:00:00 (hr:min:sec) |
| Range: | 0:00:00–9:59:59 |

Communication information

| | |
|----------------------------------|---|
| Modbus Instance no/DeviceNet no: | 43433 hours 43434 minutes 43435 seconds |
| Profibus slot/index | 170/82, 170/83, 170/84 |
| Fieldbus format | UInt |
| Modbus format | UInt |

Timer 1 T1 [644]

When timer mode is set to Alternate and Timer 1 is enabled, this timer will automatically keep on switching according to the independently programmable up and down times. The Timer 1 in Alternate mode can be enabled by a digital input or via a virtual connection. See Fig. 107. Timer 1 T1 sets the up time in the alternate mode.

| | |
|---|----------------------|
| 644 Timer 1 T1 Stp A 0:00:00 | |
| Default: | 0:00:00 (hr:min:sec) |
| Range: | 0:00:00–9:59:59 |

Communication information

| | |
|----------------------------------|---|
| Modbus Instance no/DeviceNet no: | 43436 hours 43437 minutes 43438 seconds |
| Profibus slot/index | 170/85, 170/86, 170/87 |
| Fieldbus format | UInt |
| Modbus format | UInt |

Timer 1 T2 [645]

Timer 1 T2 sets the down time in the alternate mode.

| | |
|--|---------------------|
| 645 Timer1 T2 Stp A 0:00:00 | |
| Default: | 0:00:00, hr:min:sec |
| Range: | 0:00:00–9:59:59 |

Communication information

| | |
|----------------------------------|---|
| Modbus Instance no/DeviceNet no: | 43439 hours 43440 minutes 43441 seconds |
| Profibus slot/index | 170/88, 170/89, 170/90 |
| Fieldbus format | UInt |
| Modbus format | UInt |

NOTE: Timer 1 T1 [644] and Timer 2 T1 [654] are only visible when Timer Mode is set to Alternate.

Timer 1 Value [649]

Timer 1 Value shows actual value of the timer.

| | |
|---|---------------------|
| 649 Timer1 Value Stp A 0:00:00 | |
| Default: | 0:00:00, hr:min:sec |
| Range: | 0:00:00–9:59:59 |

Communication information

| | |
|----------------------------------|---|
| Modbus Instance no/DeviceNet no: | 42921 hours 42922 minutes 42923 seconds |
| Profibus slot/index | 168/80, 168/81, 168/82 |
| Fieldbus format | UInt |
| Modbus format | UInt |

11.6.5 Timer2 [650]

Refer to the descriptions for Timer1.

Timer 2 Trig [651]

| | |
|--|---|
| 651 Timer2 Trig Stp A Off | |
| Default: | Off |
| Selection: | Same selections as Digital Output 1 menu [541]. |

Communication information

| | |
|----------------------------------|---------|
| Modbus Instance no/DeviceNet no: | 43451 |
| Profibus slot/index | 170/100 |
| Fieldbus format | UInt |
| Modbus format | UInt |

Timer 2 Mode [652]

| | |
|--|-----------------------|
| 652 Timer2 Mode Stp A Off | |
| Default: | Off |
| Selection: | Same as in menu [642] |

Communication information

| | |
|----------------------------------|---------|
| Modbus Instance no/DeviceNet no: | 43452 |
| Profibus slot/index | 170/101 |
| Fieldbus format | UInt |
| Modbus format | UInt |

Timer 2 Delay [653]

| | |
|--|---------------------|
| 653 Timer2Delay Stp A 0:00:00 | |
| Default: | 0:00:00, hr:min:sec |
| Range: | 0:00:00–9:59:59 |

Communication information

| | |
|----------------------------------|---|
| Modbus Instance no/DeviceNet no: | 43453 hours 43454 minutes 43455 seconds |
| Profibus slot/index | 170/102, 170/103, 170/104 |
| Fieldbus format | UInt |
| Modbus format | UInt |

Timer 2 T1 [654]

| | |
|---|---------------------|
| 654 Timer 2 T1 Stp A 0:00:00 | |
| Default: | 0:00:00, hr:min:sec |
| Range: | 0:00:00–9:59:59 |

Communication information

| | |
|----------------------------------|---|
| Modbus Instance no/DeviceNet no: | 43456 hours 43457 minutes 43458 seconds |
| Profibus slot/index | 170/105, 170/106, 170/107 |
| Fieldbus format | UInt |
| Modbus format | UInt |

Timer 2 T2 [655]

| | |
|---|---------------------|
| 655 Timer 2 T2 Stp A 0:00:00 | |
| Default: | 0:00:00, hr:min:sec |
| Range: | 0:00:00–9:59:59 |

Communication information

| | |
|----------------------------------|---|
| Modbus Instance no/DeviceNet no: | 43459 hours 43460 minutes 43461 seconds |
| Profibus slot/index | 170/108, 170/109, 170/110 |
| Fieldbus format | UInt |
| Modbus format | UInt |

Timer 2 Value [659]

Timer 2 Value shows actual value of the timer.

| | |
|---|---------------------|
| 659 Timer2 Value Stp A 0:00:00 | |
| Default: | 0:00:00, hr:min:sec |
| Range: | 0:00:00–9:59:59 |

Communication information

| | |
|----------------------------------|---|
| Modbus Instance no/DeviceNet no: | 42924 hours 42925 minutes 42926 seconds |
| Profibus slot/index | 168/83, 168/84, 168/84 |
| Fieldbus format | UInt |
| Modbus format | UInt |

11.7 View Operation/Status [700]

Menu with parameters for viewing all actual operational data, such as speed, torque, power, etc.

11.7.1 Operation [710]

Process Value [711]

The process value is showing the process actual value, depending on selection done in chapter Process Source [321].

| | |
|-------------------------------|--|
| 711 Process Val Stp | |
| Unit | Depends on selected Process source [321] and Process Unit [322]. |
| Resolution | Speed: 1 rpm, 4 digits Other units: 3 digits |

Communication information

| | |
|----------------------------------|---------------|
| Modbus Instance no/DeviceNet no: | 31001 |
| Profibus slot/index | 121/145 |
| Fieldbus format | Long, 1=0.001 |
| Modbus format | EInt |

Speed [712]

Displays the actual shaft speed.

| | |
|--|-----------------|
| 712 Speed Stp rpm | |
| Unit: | rpm |
| Resolution: | 1 rpm, 4 digits |

Communication information

| | |
|----------------------------------|--------------|
| Modbus Instance no/DeviceNet no: | 31002 |
| Profibus slot/index | 121/146 |
| Fieldbus format | Int, 1=1 rpm |
| Modbus format | Int, 1=1 rpm |

Torque [713]

Displays the actual shaft torque.

| | |
|-----------------------------------|-------------|
| 713 Torque Stp 0% 0.0Nm | |
| Unit: | %, Nm |
| Resolution: | 1 %, 0.1 Nm |

Communication information

| | |
|----------------------------------|-------------------------------|
| Modbus Instance no/DeviceNet no: | 31003 Nm 31004 % |
| Profibus slot/index | 121/147 121/148 |
| Fieldbus format | Long, 1=0.1 Nm Long, 1=1 % |
| Modbus format | Elnt |

Shaft power [714]

Displays the actual shaft power.

| | |
|---------------------------------|----|
| 714 Shaft Power Stp W | |
| Unit: | W |
| Resolution: | 1W |

Communication information

| | |
|----------------------------------|------------|
| Modbus Instance no/DeviceNet no: | 31005 |
| Profibus slot/index | 121/149 |
| Fieldbus format | Long, 1=1W |
| Modbus format | Elnt |

Electrical Power [715]

Displays the actual electrical output power.

| | |
|-------------------------------|-----|
| 715 El Power Stp kW | |
| Unit: | kW |
| Resolution: | 1 W |

Communication information

| | |
|----------------------------------|------------|
| Modbus Instance no/DeviceNet no: | 31006 |
| Profibus slot/index | 121/150 |
| Fieldbus format | Long, 1=1W |
| Modbus format | Elnt |

Current [716]

Displays the actual output current.

| | |
|-----------------------------|-------|
| 716 Current Stp A | |
| Unit: | A |
| Resolution: | 0.1 A |

Communication information

| | |
|----------------------------------|---------------|
| Modbus Instance no/DeviceNet no: | 31007 |
| Profibus slot/index | 121/151 |
| Fieldbus format | Long, 1=0.1 A |
| Modbus format | Elnt |

Output Voltage [717]

Displays the actual output voltage.

| | |
|---------------------------------|-------|
| 717 Output Volt Stp V | |
| Unit: | V |
| Resolution: | 0.1 V |

Communication information

| | |
|----------------------------------|---------------|
| Modbus Instance no/DeviceNet no: | 31008 |
| Profibus slot/index | 121/152 |
| Fieldbus format | Long, 1=0.1 V |
| Modbus format | Elnt |

Frequency [718]

Displays the actual output frequency.

| | |
|--------------------------------|--------|
| 718 Frequency Stp Hz | |
| Unit: | Hz |
| Resolution: | 0.1 Hz |

Communication information

| | |
|----------------------------------|----------------|
| Modbus Instance no/DeviceNet no: | 31009 |
| Profibus slot/index | 121/153 |
| Fieldbus format | Long, 1=0.1 Hz |
| Modbus format | Elnt |

DC Link Voltage [719]

Displays the actual DC link voltage.

| | |
|--------------------------------|-------|
| 719 DC Voltage Stp V | |
| Unit: | V |
| Resolution: | 0.1 V |

Communication information

| | |
|----------------------------------|---------------|
| Modbus Instance no/DeviceNet no: | 31010 |
| Profibus slot/index | 121/154 |
| Fieldbus format | Long, 1=0.1 V |
| Modbus format | Elnt |

Heatsink Temperature [71A]

Displays the actual heatsink temperature, measured.
The signal is generated by a sensor in the IGBT module.

| | |
|-----------------------------------|--------|
| 71A Heatsink Tmp Stp °C | |
| Unit: | °C |
| Resolution: | 0.1 °C |

Communication information

| | |
|----------------------------------|----------------|
| Modbus Instance no/DeviceNet no: | 31011 |
| Profibus slot/index | 121/155 |
| Fieldbus format | Long, 1=0.1 °C |
| Modbus format | Elnt |

PT100_1_2_3 Temp [71B]

Displays the actual PT100 temperature.

| | |
|----------------------------------|------|
| 71B PT100 1,2,3 Stp °C | |
| Unit: | °C |
| Resolution: | 1 °C |

Communication information

| | |
|----------------------------------|-------------------------------|
| Modbus Instance no/DeviceNet no: | 31012, 31013, 31014 |
| Profibus slot/index | 121/156 121/157 121/158 |
| Fieldbus format | Long, 1=1 °C |
| Modbus format | Elnt |

11.7.2 Status [720]

VSD Status [721]

Indicates the overall status of the AC drive.

| |
|-----------------------|
| 721 VSD Status |
| Stp 1/222/333/44 |

Fig. 108 AC drive status

| Display position | Status | Value |
|------------------|-----------------------------------|---|
| 1 | Parameter Set | A,B,C,D |
| 222 | Source of reference value | -Key (keyboard) -Rem (remote) -Com (Serial comm.) -Opt (option) |
| 333 | Source of Run/ Stop/Reset command | -Key (keyboard) -Rem (remote) -Com (Serial comm.) -Opt (option) |
| 44 | Limit functions | -TL (Torque Limit) -SL (Speed Limit) -CL (Current Limit) -VL (Voltage Limit) - - -No limit active |

Example: "A/Key/Rem/TL"

This means:

- A: Parameter Set A is active.
- Key: Reference value comes from the keyboard (CP).
- Rem: Run/Stop commands come from terminals 1-22.
- TL: Torque Limit active.

Warning [722]

Display the actual or last warning condition. A warning occurs if the AC drive is close to a trip condition but still in operation. During a warning condition the red trip LED will start to blink as long as the warning is active.

| |
|---------------------|
| 722 Warnings |
| Stp warn.msg |

The active warning message is displayed in menu [722]. If no warning is active the message "No Error" is displayed.

The following warnings are possible:

| Fieldbus integer value | Warning message |
|------------------------|------------------------|
| 0 | No Error |
| 1 | Motor I ² t |
| 2 | PTC |
| 3 | Motor lost |
| 4 | Locked rotor |
| 5 | Ext trip |
| 6 | Mon MaxAlarm |
| 7 | Mon MinAlarm |
| 8 | Comm error |
| 9 | PT100 |
| 10 | Deviation |
| 11 | Pump |
| 12 | Ext Mot Temp |
| 13 | LC Level |
| 14 | Brake |
| 15 | Option |
| 16 | Over temp |
| 17 | Over curr F |
| 18 | Over volt D |
| 19 | Over volt G |
| 20 | Over volt M |
| 21 | Over speed |
| 22 | Under voltage |
| 23 | Power fault |
| 24 | Desat |
| 25 | DClk error |
| 26 | Int error |
| 27 | Ovolt m cut |
| 28 | Over voltage |
| 29 | Not used |
| 30 | Not used |
| 31 | Not used |

Communication information

| | |
|----------------------------------|---------|
| Modbus Instance no/DeviceNet no: | 31016 |
| Profibus slot/index | 121/160 |
| Fieldbus format | Long |
| Modbus format | UInt |

See also the Chapter 12. page 169.

Digital Input Status [723]

Indicates the status of the digital inputs. See Fig. 109.

- 1 DigIn 1
- 2 DigIn 2
- 3 DigIn 3
- 4 DigIn 4
- 5 DigIn 5
- 6 DigIn 6
- 7 DigIn 7
- 8 DigIn 8

The positions one to eight (read from left to right) indicate the status of the associated input:

- 1 High
- 0 Low

The example in Fig. 109 indicates that DigIn 1, DigIn 3 and DigIn 6 are active at this moment.

```
723 DigIn Status
Stp   1010 0100
```

Fig. 109 Digital input status example

Communication information

| | |
|----------------------------------|----------------------------------|
| Modbus Instance no/DeviceNet no: | 31017 |
| Profibus slot/index | 121/161 |
| Fieldbus format | UInt, bit 0=DigIn1, bit 8=DigIn8 |
| Modbus format | |

Digital Output Status [724]

Indicates the status of the digital outputs and relays. See Fig. 110.

RE indicate the status of the relays on position:

- 1 Relay1
- 2 Relay2
- 3 Relay3

DO indicate the status of the digital outputs on position:

- 1 DigOut1
- 2 DigOut2

The status of the associated output is shown.

- 1 High
- 0 Low

The example in Fig. 110 indicates that DigOut1 is active and Digital Out 2 is not active. Relay 1 is active, relay 2 and 3 are not active.

```
724 DigOutStatus
Stp RE 100 DO 10
```

Fig. 110 Digital output status example

Communication information

| | |
|----------------------------------|---|
| Modbus Instance no/DeviceNet no: | 31018 |
| Profibus slot/index | 121/162 |
| Fieldbus format | UInt, bit 0=DigOut1, bit 1=DigOut2, bit 8=Relay1, bit 9=Relay2, bit 10=Relay3 |
| Modbus format | |

Analogue Input Status [725]

Indicates the status of the analogue inputs 1 and 2.

```
725 AnIn 1 2
Stp   -100% 65%
```

Fig. 111 Analogue input status

Communication information

| | |
|----------------------------------|------------------|
| Modbus Instance no/DeviceNet no: | 31019, 31020 |
| Profibus slot/index | 121/163, 121/164 |
| Fieldbus format | Long, 1=1% |
| Modbus format | EInt |

The first row indicates the analogue inputs.

- 1 AnIn 1
- 2 AnIn 2

Reading downwards from the first row to the second row the status of the belonging input is shown in %:

-100% AnIn1 has a negative 100% input value
65% AnIn2 has a 65% input value

So the example in Fig. 111 indicates that both the Analogue inputs are active.

NOTE: The shown percentages are absolute values based on the full range/scale of the in- our output; so related to either 0–10 V or 0–20 mA.

Analogue Input Status [726]

Indicates the status of the analogue inputs 3 and 4.

| | |
|-------------------|-----------|
| 726 AnIn 3 | 4 |
| Stp | -100% 65% |

Fig. 112 Analogue input status

Communication information

| | |
|----------------------------------|------------------|
| Modbus Instance no/DeviceNet no: | 31021, 31022 |
| Profibus slot/index | 121/165, 121/166 |
| Fieldbus format | Long, 1=1% |
| Modbus format | Elnt |

Analogue Output Status [727]

Indicates the status of the analogue outputs. Fig. 109.
E.g. if 4-20 mA output is used, the value 20% equals to 4 mA.

| | |
|--------------------|-----------|
| 727 AnOut 1 | 2 |
| Stp | -100% 65% |

Fig. 113 Analogue output status

Communication information

| | |
|----------------------------------|------------------|
| Modbus Instance no/DeviceNet no: | 31023, 31024 |
| Profibus slot/index | 121/167, 121/168 |
| Fieldbus format | Long, 1=1% |
| Modbus format | Elnt |

The first row indicates the Analogue outputs.

- 1 AnOut 1
- 2 AnOut 2

Reading downwards from the first row to the second row the status of the belonging output is shown in %:

-100%AnOut1 has a negative 100% output value

65%AnOut2 has a 65% output value

The example in Fig. 109 indicates that both the Analogue outputs are active.

NOTE: The shown percentages are absolute values based on the full range/scale of the in- our output; so related to either 0-10 V or 0-20 mA.

I/O board Status [728] - [72A]

Indicates the status for the additional I/O on option boards 1 (B1), 2 (B2) and 3 (B3).

| |
|------------------|
| 728 IO B1 |
| Stp RE000 DI10 |

Communication information

| | |
|----------------------------------|--|
| Modbus Instance no/DeviceNet no: | 31025 - 31027 |
| Profibus slot/index | 121/170 - 172 |
| Fieldbus format | UInt, bit 0=DigIn1 bit 1=DigIn2 bit 2=DigIn3 |
| Modbus format | bit 8=Relay1 bit 9=Relay2 bit 10=Relay3 |

11.7.3 Stored values [730]

The shown values are the actual values built up over time. Values are stored at power down and updated again at power up.

Run Time [731]

Displays the total time that the AC drive has been in the Run Mode.

| | |
|---|------------------------------------|
| 731 Run Time Stp h:mm:ss | |
| Unit: | h: mm:ss (hours: minutes: seconds) |
| Range: | 00: 00: 00-262143: 59: 59 |

Communication information

| | |
|----------------------------------|-----------------------------------|
| Modbus Instance no/DeviceNet no: | 31028:31029:31030 (hr:min:sec) |
| Profibus slot/index | 121/172:121/173: 121/174 |
| Fieldbus format | UInt, 1=1h/m/s |
| Modbus format | UInt, 1=1h/m/s |

Reset Run Time [7311]

Reset the run time counter. The stored information will be erased and a new registration period will start.

| | |
|--|----|
| 7311 Reset RunTm Stp No | |
| Default: | No |
| No | 0 |
| Yes | 1 |

Communication information

| | |
|----------------------------------|------|
| Modbus Instance no/DeviceNet no: | 7 |
| Profibus slot/index | 0/6 |
| Fieldbus format | UInt |
| Modbus format | UInt |

NOTE: After reset the setting automatically reverts to "No".

Mains time [732]

Displays the total time that the AC drive has been connected to the mains supply. This timer cannot be reset.

| | |
|---|------------------------------------|
| 732 Mains Time Stp h:mm:ss | |
| Unit: | h: mm:ss (hours: minutes: seconds) |
| Range: | 00: 00: 00-262143: 59: 59 |

Communication information

| | |
|----------------------------------|-----------------------------------|
| Modbus Instance no/DeviceNet no: | 31031:31032:31033 (hr:min:sec) |
| Profibus slot/index | 121/175:121/176: 121/177 |
| Fieldbus format | UInt, 1=1h/m/s |
| Modbus format | UInt, 1=1h/m/s |

Energy [733]

Displays the total energy consumption since the last energy reset [7331] took place.

| | |
|---|--------------------------------|
| 733 Energy Stp kWh | |
| Unit: | Wh (shows Wh, kWh, MWh or GWh) |
| Range: | 0.0-999999GWh |

Communication information

| | |
|----------------------------------|-------------|
| Modbus Instance no/DeviceNet no: | 31034 |
| Profibus slot/index | 121/178 |
| Fieldbus format | Long, 1=1 W |
| Modbus format | EInt |

Reset Energy [7331]

Resets the energy counter. The stored information will be erased and a new registration period will start.

| | |
|----------------------------------|---------|
| 7331 Rst Energy Stp No | |
| Default: | No |
| Selection: | No, Yes |

Communication information

| | |
|----------------------------------|------|
| Modbus Instance no/DeviceNet no: | 6 |
| Profibus slot/index | 0/5 |
| Fieldbus format | UInt |
| Modbus format | UInt |

NOTE: After reset the setting automatically goes back to "No".

11.8 View Trip Log [800]

Main menu with parameters for viewing all the logged trip data. In total the AC drive saves the last 10 trips in the trip memory. The trip memory refreshes on the FIFO principle (First In, First Out). Every trip in the memory is logged on the time of the Run Time [731] counter. At every trip, the actual values of several parameter are stored and available for troubleshooting.

11.8.1 Trip Message log [810]

Display the cause of the trip and what time that it occurred. When a trip occurs the status menus are copied to the trip message log. There are nine trip message logs [810]–[890]. When the tenth trip occurs the oldest trip will disappear.

| | |
|--|-----------------------|
| 8x0 Trip message Stp h:mm:ss | |
| Unit: | h: m (hours: minutes) |
| Range: | 0h: 0m–65355h: 59m |

| |
|--------------------------------------|
| 810 Ext Trip Stp 132:12:14 |
|--------------------------------------|

For fieldbus integer value of trip message, see message table for warnings, [722].

NOTE: Bits 0–5 used for trip message value. Bits 6–15 for internal use.

Communication information

| | |
|----------------------------------|---------|
| Modbus Instance no/DeviceNet no: | 31101 |
| Profibus slot/index | 121/245 |
| Fieldbus format | UInt |
| Modbus format | UInt |

Trip message [811]-[81N]

The information from the status menus are copied to the trip message log when a trip occurs.

| Trip menu | Copied from | Description |
|-----------|-------------|----------------------------|
| 811 | 711 | Process Value |
| 812 | 712 | Speed |
| 813 | 712 | Torque |
| 814 | 714 | Shaft Power |
| 815 | 715 | Electrical Power |
| 816 | 716 | Current |
| 817 | 717 | Output voltage |
| 818 | 718 | Frequency |
| 819 | 719 | DC Link voltage |
| 81A | 71A | Heatsink Temperature |
| 81B | 71B | PT100_1, 2, 3 |
| 81C | 721 | AC drive Status |
| 81D | 723 | Digital input status |
| 81E | 724 | Digital output status |
| 81F | 725 | Analogue input status 1-2 |
| 81G | 726 | Analogue input status 3-4 |
| 81H | 727 | Analogue output status 1-2 |
| 81I | 728 | I/O status option board 1 |
| 81J | 729 | I/O status option board 2 |
| 81K | 72A | I/O status option board 3 |
| 81L | 731 | Run Time |
| 81M | 732 | Mains Time |
| 81N | 733 | Energy |
| 81O | 310 | Process reference |

Communication information

| | |
|----------------------------------|---|
| Modbus Instance no/DeviceNet no: | 31102 - 31135 |
| Profibus slot/index | 121/246 - 254, 122/0 - 24 |
| Fieldbus format | Depends on parameter, see respective parameter. |
| Modbus format | Depends on parameter, see respective parameter. |

Example:

Fig. 110 shows the third trip memory menu [830]: Over temperature trip occurred after 1396 hours and 13 minutes in Run time.

| |
|----------------------|
| 830 Over temp |
| Stp 1396h:13m |

Fig. 114 Trip 3

11.8.2 Trip Messages [820] - [890]

Same information as for menu [810].

Communication information

| | | |
|--------------------------------------|---|---------------|
| Modbus Instance no/ DeviceNet no: | 31151-31185 | Trip log list |
| | 31201-31235 | 2 |
| | 31251-31285 | 3 |
| | 31301-31335 | 4 |
| | 31351-31385 | 5 |
| | 31401-31435 | 6 |
| | 31451-31485 | 7 |
| | 31501-31535 | 8 |
| | 31501-31535 | 9 |
| Profibus slot/index | 122/40-122/74 | Trip log list |
| | 122/90-122/124 | 2 |
| | 122/140-122/174 | 3 |
| | 122/190-122/224 | 4 |
| | 122/240-123/18 | 5 |
| | 123/35 - 123/68 | 6 |
| | 123/85-123/118 | 7 |
| | 123/135-123/168 | 8 |
| | 123/135-123/168 | 9 |
| Fieldbus format | Depends on parameter, see respective parameter. | |
| Modbus format | Depends on parameter, see respective parameter. | |

All nine alarm lists contain the same type of data. For example DeviceNet parameter 31101 in alarm list 1 contains the same data information as 31151 in alarm list 2. It is possible to read all parameters in alarm lists 2-9 by recalculating the DeviceNet instance number into a Profibus slot/index number. This is done in the following way:

slot no = $\text{abs}((\text{dev instance no}-1)/255)$
index no = $(\text{dev instance no}-1) \text{ modulo } 255$
dev instance no = $\text{slot no} \times 255 + \text{index no} + 1$

Example: We want to read out the process value out from alarm list 9. In alarm list 1 process value has the DeviceNet instance number 31102. In alarm list 9 it has DeviceNet instance no 31502 (see table 2 above). The corresponding slot/index no is then:

slot no = $\text{abs}((31502-1)/255)=123$
index no (modulo)= the remainder of the division above = 136, calculated as: $(31502-1)-123 \times 255=136$

11.8.3 Reset Trip Log [8A0]

Resets the content of the 10 trip memories.

| | |
|-----------------------|----|
| 8A0 Reset Trip | |
| Stp | No |
| Default: | No |
| No | 0 |
| Yes | 1 |

Communication information

| | |
|----------------------------------|------|
| Modbus Instance no/DeviceNet no: | 8 |
| Profibus slot/index | 0/7 |
| Fieldbus format | UInt |
| Modbus format | UInt |

NOTE: After the reset the setting goes automatically back to "NO". The message "OK" is displayed for 2 sec.

11.9 System Data [900]

Main menu for viewing all the AC drive system data.

11.9.1 VSD Data [920]

VSD Type [921]

Shows the AC drive type according to the type number.

The options are indicated on the type plate of the AC drive.

NOTE: If the control board is not configured, then type type shown is JNVX40-XXXX.

| | |
|------------|--------------------|
| 921 | V332.0 |
| Stp | JNVX48-0046 |

Example of type

Communication information

| | |
|----------------------------------|---------|
| Modbus Instance no/DeviceNet no: | 31037 |
| Profibus slot/index | 121/181 |
| Fieldbus format | Long |
| Modbus format | Text |

Examples:

JNVX48-046AC drive-series suited for 380-480 volt mains supply, and a rated output current of 46 A.

Software [922]

Shows the software version number of the AC drive.

Fig. 115 gives an example of the version number.

| |
|---------------------|
| 922 Software |
| Stp V 4.30 |

Fig. 115 Example of software version

Communication information

| | |
|----------------------------------|--|
| Modbus Instance no/DeviceNet no: | 31038 software version 31039 option version |
| Profibus slot/index | 121/182-183 |
| Fieldbus format | UInt |
| Modbus format | UInt |

Table 28 Information for Modbus and Profibus number, software version

| Bit | Description |
|-------|--|
| 7-0 | minor |
| 13-8 | major |
| 15-14 | release 00: V, release version 01: P, pre-release version 10: β, Beta version 11: α, Alpha version |

Table 29 Information for Modbus and Profibus number, option version

| Bit | Description |
|------|-------------|
| 7-0 | minor |
| 15-8 | major |

V 4.30 = Version of the Software

NOTE: It is important that the software version displayed in menu [922] is the same software version number as the software version number written on the title page of this instruction manual. If not, the functionality as described in this manual may differ from the functionality of the AC drive.

Unit name [923]

Option to enter a name of the unit for service use or customer identity. The function enables the user to define a name with 12 symbols. Use the Prev and Next key to move the cursor to the required position. Then use the + and - keys to scroll in the character list. Confirm the character by moving the cursor to the next position by pressing the Next key. See section User-defined Unit [323].

Example

Create user name USER 15.

1. When in the menu [923] press Next to move the cursor to the right most position.
2. Press the + key until the character U is displayed.
3. Press Next.
4. Then press the + key until S is displayed and confirm with Next.
5. Repeat until you have entered USER15.

| |
|------------------------------|
| 923 Unit Name Stp |
| Default: No characters shown |

Communication information

| | |
|----------------------------------|-------------|
| Modbus Instance no/DeviceNet no: | 42301-42312 |
| Profibus slot/index | 165/225-236 |
| Fieldbus format | UInt |
| Modbus format | UInt |

When sending a unit name you send one character at a time starting at the right most position.

12. Troubleshooting, Diagnoses and Maintenance

12.1 Trips, warnings and limits

In order to protect the AC drive the principal operating variables are continuously monitored by the system. If one of these variables exceeds the safety limit an error/warning message is displayed. In order to avoid any possibly dangerous situations, the inverter sets itself into a stop Mode called Trip and the cause of the trip is shown in the display.

Trips will always stop the AC drive. Trips can be divided into normal and soft trips, depending on the setup Trip Type, see menu [250] Autoreset. Normal trips are default. For normal trips the AC drive stops immediately, i.e. the motor coasts naturally to a standstill. For soft trips the AC drive stops by ramping down the speed, i.e. the motor decelerates to a standstill.

“Normal Trip”

- The AC drive stops immediately, the motor coasts to naturally to a standstill.
- The Trip relay or output is active (if selected).
- The Trip LED is on.
- The accompanying trip message is displayed.
- The “TRP” status indication is displayed (area D of the display).

“Soft Trip”

- the AC drive stops by decelerating to a standstill.

During the deceleration.

- The accompanying trip message is displayed, including an additional soft trip indicator “S” before the trip time.
- The Trip LED is flashing.
- The Warning relay or output is active (if selected).

After standstill is reached.

- The Trip LED is on.
- The Trip relay or output is active (if selected).
- The “TRP” status indication is displayed (area D of the display).

Apart from the TRIP indicators there are two more indicators to show that the inverter is in an “abnormal” situation.

“Warning”

- The inverter is close to a trip limit.
- The Warning relay or output is active (if selected).
- The Trip LED is flashing.
- The accompanying warning message is displayed in window [722] Warning.
- One of the warning indications is displayed (area F of the display).

“Limits”

- The inverter is limiting torque and/or frequency to avoid a trip.
- The Limit relay or output is active (if selected).
- The Trip LED is flashing.
- One of the Limit status indications is displayed (area D of the display).

Table 30 List of trips and warnings

| Trip/Warning messages | Selections | Trip (Normal/Soft) | Warning indicators (Area D) |
|---------------------------|----------------------------|--------------------|-----------------------------|
| Motor I ² t | Trip/Off/Limit | Normal/Soft | I ² t |
| PTC | Trip/Off | Normal/Soft | |
| Motor PTC | On | Normal | |
| PT100 | Trip/Off | Normal/Soft | |
| Motor lost | Trip/Off | Normal | |
| Locked rotor | Trip/Off | Normal | |
| Ext trip | Via DigIn | Normal/Soft | |
| Ext Mot Temp | Via DigIn | Normal/Soft | |
| Mon MaxAlarm | Trip/Off/Warn | Normal/Soft | |
| Mon MinAlarm | Trip/Off/Warn | Normal/Soft | |
| Comm error | Trip/Off/Warn | Normal/Soft | |
| Deviation | Via Option | Normal | |
| Pump | Via Option | Normal | |
| Over temp | On | Normal | OT |
| Over curr F | On | Normal | |
| Over volt D | On | Normal | |
| Over volt G | On | Normal | |
| Over volt | On | Normal | |
| Over speed | On | Normal | |
| Under voltage | On | Normal | LV |
| LC Level | Trip/Off/Warn Via DigIn | Normal/Soft | LCL |
| Desat ### * | On | Normal | |
| DClint error | On | Normal | |
| Power Fault PF ##### * | On | Normal | |
| Ovolt m cut | On | Normal | |
| Over voltage | Warning | | VL |
| Safe stop | Warning | | SST |
| Brake | Trip/Off/Warn | Normal | |
| OPTION | On | Normal | |

*) Refer to table Table 31 regarding which Desat or Power Fault is triggered.

12.2 Trip conditions, causes and remedial action

The table later on in this section must be seen as a basic aid to find the cause of a system failure and to how to solve any problems that arise. An AC drive is mostly just a small part of a complete AC drive system. Sometimes it is difficult to determine the cause of the failure, although the AC drive gives a certain trip message it is not always easy to find the right cause of the failure. Good knowledge of the complete drive system is therefore necessary. Contact your supplier if you have any questions.

The AC drive is designed in such a way that it tries to avoid trips by limiting torque, overvolt etc.

Failures occurring during commissioning or shortly after commissioning are most likely to be caused by incorrect settings or even bad connections.

Failures or problems occurring after a reasonable period of failure-free operation can be caused by changes in the system or in its environment (e.g. wear).

Failures that occur regularly for no obvious reasons are generally caused by Electro Magnetic Interference. Be sure that the installation fulfils the demands for installation stipulated in the EMC directives. See chapter 8, page 51.

Sometimes the so-called "Trial and error" method is a quicker way to determine the cause of the failure. This can be done at any level, from changing settings and functions to disconnecting single control cables or replacing entire drives.

The Trip Log can be useful for determining whether certain trips occur at certain moments. The Trip Log also records the time of the trip in relation to the run time counter.



WARNING!

If it is necessary to open the AC drive or any part of the system (motor cable housing, conduits, electrical panels, cabinets, etc.) to inspect or take measurements as suggested in this instruction manual, it is absolutely necessary to read and follow the safety instructions in the manual.

12.2.1 Technically qualified personnel

Installation, commissioning, demounting, making measurements, etc., of or at the AC drive may only be carried out by personnel technically qualified for the task.

12.2.2 Opening the AC drive



WARNING!

Always switch the mains voltage off if it is necessary to open the AC drive and wait at least 7 minutes to allow the capacitors to discharge.



WARNING!

In case of malfunctioning always check the DC-link voltage, or wait one hour after the mains voltage has been switched off, before dismantling the AC drive for repair.

The connections for the control signals and the switches are isolated from the mains voltage. Always take adequate precautions before opening the AC drive.

12.2.3 Precautions to take with a connected motor

If work must be carried out on a connected motor or on the driven machine, the mains voltage must always first be disconnected from the AC drive. Wait at least 7 minutes before continuing.

12.2.4 Autoreset Trip

If the maximum number of Trips during Autoreset has been reached, the trip message hour counter is marked with an "A".

```
830 OVERVOLT G
Trp A 345:45:12
```

Fig. 116 Autoreset trip

Fig. 116 shows the 3rd trip memory menu [830]: Overvoltage G trip after the maximum Autoreset attempts took place after 345 hours, 45 minutes and 12 seconds of run time.

Table 31 Trip condition, their possible causes and remedial action

| Trip condition | Possible Cause | Remedy | Size** |
|--|---|--|--------|
| Motor I ² t "I ² t" | I ² t value is exceeded. - Overload on the motor according to the programmed I ² t settings. | - Check on mechanical overload on the motor or the machinery (bearings, gearboxes, chains, belts, etc.) - Change the Motor I ² t Current setting in menu group [230] | |
| PTC | Motor thermistor (PTC) exceeds maximum level. NOTE: Only valid if option board PTC/PT100 is used. | - Check on mechanical overload on the motor or the machinery (bearings, gearboxes, chains, belts, etc.) - Check the motor cooling system. - Self-cooled motor at low speed, too high load. - Set PTC, menu [234] to OFF | |
| Motor PTC | Motor thermistor (PTC) exceeds maximum level. NOTE: Only valid if [237] is enabled. | - Check on mechanical overload on the motor or the machinery (bearings, gearboxes, chains, belts, etc.) - Check the motor cooling system. - Self-cooled motor at low speed, too high load. - Set PTC, menu [237] to OFF | B,C,D |
| PT100 | Motor PT100 elements exceeds maximum level. NOTE: Only valid if option board PTC/PT100 is used. | - Check on mechanical overload on the motor or the machinery (bearings, gearboxes, chains, belts, etc.) - Check the motor cooling system. - Self-cooled motor at low speed, too high load. - Set PT100 to OFF, menu [234] | |
| Motor lost | Phase loss or too great imbalance on the motor phases | - Check the motor voltage on all phases. - Check for loose or poor motor cable connections - If all connections are OK, contact your supplier - Set motor lost alarm to OFF. | |
| Locked rotor | Torque limit at motor standstill: - Mechanical blocking of the rotor. | - Check for mechanical problems at the motor or the machinery connected to the motor - Set locked rotor alarm to OFF. | |
| Ext trip | External input (DigIn 1-8) active: - active low function on the input. | - Check the equipment that initiates the external input - Check the programming of the digital inputs DigIn 1-8 | |
| Ext Mot Temp | External input (DigIn 1-8) active: - active low function on the input. | - Check the equipment that initiates the external input - Check the programming of the digital inputs DigIn 1-8 | |
| Mon MaxAlarm | Max alarm level (overload) has been reached. | - Check the load condition of the machine - Check the monitor setting in section 11.6, page 140. | |
| Mon MinAlarm | Min alarm level (underload) has been reached. | - Check the load condition of the machine - Check the monitor setting in section 11.6, page 140. | |

Table 31 Trip condition, their possible causes and remedial action

| Trip condition | Possible Cause | Remedy | Size** |
|--------------------------|--|--|--------|
| Comm error | Error on serial communication (option) | <ul style="list-style-type: none"> - Check cables and connection of the serial communication. - Check all settings with regard to the serial communication - Restart the equipment including the AC drive | |
| Deviation | CRANE board detecting deviation in motor operation. NOTE: Only used in Crane Control. | <ul style="list-style-type: none"> - Check encoder signals - Check Deviation jumper on Crane option board. - Check the settings in menu group [264] | |
| Pump | No master pump can be selected due to error in feedback signalling. NOTE: Only used in Pump Control. | <ul style="list-style-type: none"> - Check cables and wiring for Pump feedback signals - Check settings with regard to the pump feedback digital inputs | |
| Over temp | Heatsink temperature too high: <ul style="list-style-type: none"> - Too high ambient temperature of the AC drive - Insufficient cooling - Too high current - Blocked or stuffed fans | <ul style="list-style-type: none"> - Check the cooling of the AC drive cabinet. - Check the functionality of the built-in fans. The fans must switch on automatically if the heatsink temperature gets too high. At power up the fans are briefly switched on. - Check AC drive and motor rating - Clean fans | |
| Over curr F | Motor current exceeds the peak AC drive current: <ul style="list-style-type: none"> - Too short acceleration time. - Too high motor load - Excessive load change - Soft short-circuit between phases or phase to earth - Poor or loose motor cable connections - Too high IxR Compensation level | <ul style="list-style-type: none"> - Check the acceleration time settings and make them longer if necessary. - Check the motor load. - Check on bad motor cable connections - Check on bad earth cable connection - Check on water or moisture in the motor housing and cable connections. - Lower the level of IxR Compensation [352] | |
| Over volt D(eceleration) | Too high DC Link voltage: <ul style="list-style-type: none"> - Too short deceleration time with respect to motor/machine inertia. | <ul style="list-style-type: none"> - Check the deceleration time settings and make them longer if necessary. - Check the dimensions of the brake resistor and the functionality of the Brake chopper (if used) | |
| Over volt G(eneration) | <ul style="list-style-type: none"> - Too small brake resistor malfunctioning Brake chopper | | |
| Over volt (Mains) | Too high DC Link voltage, due to too high mains voltage | <ul style="list-style-type: none"> - Check the main supply voltage - Try to take away the interference cause or use other main supply lines. | |
| O(ver) volt M(ains) cut | | | |
| Over speed | Motor speed measurement exceeds maximum level. 110% of max speed (all parameter sets). | Check encoder cables, wiring and setup Check motor data setup [22x] Perform short ID-run | |
| Under voltage | Too low DC Link voltage: <ul style="list-style-type: none"> - Too low or no supply voltage - Mains voltage dip due to starting other major power consuming machines on the same line. | <ul style="list-style-type: none"> - Make sure all three phases are properly connected and that the terminal screws are tightened. - Check that the mains supply voltage is within the limits of the AC drive. - Try to use other mains supply lines if dip is caused by other machinery - Use the function low voltage override [421] | |
| LC Level | Low liquid cooling level in external reservoir. External input (DigIn 1-8) active: <ul style="list-style-type: none"> - active low function on the input. NOTE: Only valid for AC drive types with Liquid Cooling option. | <ul style="list-style-type: none"> - Check liquid cooling - Check the equipment and wiring that initiates the external input - Check the programming of the digital inputs DigIn 1-8 | |
| OPTION | If an Option specific trip occurs | Check the description of the specific option | |

Table 31 Trip condition, their possible causes and remedial action

| Trip condition | Possible Cause | Remedy | Size** |
|----------------|---|---|--------|
| Desat | Failure in output stage, - desaturation of IGBTs - Hard short circuit between phases or phase to earth - Earth fault - For size B - D also the Brake IGBT | <ul style="list-style-type: none"> - Check on bad motor cable connections - Check on bad earth cable connections - Check on water and moisture in the motor housing and cable connections - Check that the rating plate data of the motor is correctly entered. - Check the brake resistor, brake IGBT and wiring. | B - D |
| Desat U+ * | | | E & Up |
| Desat U- * | | | |
| Desat V+ * | | | |
| Desat V- * | | | |
| Desat W+ * | | | |
| Desat W- * | | | |
| Desat BCC * | | | |
| DC link error | DC link voltage ripple exceeds maximum level | <ul style="list-style-type: none"> - Make sure all three phases are properly connected and that the terminal screws are tightened. - Check that the mains supply voltage is within the limits of the AC drive. - Try to use other mains supply lines if dip is caused by other machinery. | |
| Power Fault | One of the 10 PF (Power Fault) trips below has occurred, but could not be determined. | <ul style="list-style-type: none"> - Check the PF errors and try to determine the cause. The trip history can be helpful. | |
| PF Fan Err * | Error in fan module | <ul style="list-style-type: none"> - Check for clogged air inlet filters in panel door and blocking material in fan module. | E & Up |
| PF HCB Err* | Error in controlled rectifier module (HCB) | <ul style="list-style-type: none"> - Check mains supply voltage | D & Up |
| PF Curr Err * | Error in current balancing: - between different modules. - between two phases within one module. | <ul style="list-style-type: none"> - Check motor. - Check fuses and line connections - Check the individual motor current leads with an clamp on amp meter. | G & Up |
| PF Overvolt * | Error in voltage balancing, overvoltage detected in one of the power modules (PEBB) | <ul style="list-style-type: none"> - Check motor. - Check fuses and line connections. | G & Up |
| PF Comm Err * | Internal communication error | Contact service | |
| PF Int Temp * | Internal temperature too high | Check internal fans | |
| PF Temp Err * | Malfunction in temperature sensor | Contact service | |
| PF DC Err * | DC-link error and mains supply fault | <ul style="list-style-type: none"> - Check mains supply voltage - Check fuses and line connections. | D & Up |
| PF Sup Err * | Mains supply fault | <ul style="list-style-type: none"> - Check mains supply voltage - Check fuses and line connections. | |
| Brake | Brake tripped on brake fault (not released) or Brake not engaged during stop. | <ul style="list-style-type: none"> - Check Brake acknowledge signal wiring to selected digital input. - Check programming of digital input DigIn 1-8, [520]. - Check circuit breaker feeding mechanical brake circuit. - Check mechanical brake if acknowledge signal is wired from brake limit switch. - Check brake contactor. - Check settings [33C], [33D], [33E], [33F]. | |

* = 2...6 Module number if parallel power units (size 300–1500 A)

** = If no size is mentioned in this column, the information is valid for all sizes.

12.3 Maintenance

The AC drive is designed not to require any servicing or maintenance. There are however some things which must be checked regularly.

All AC drives have built-in fan which is speed controlled using heatsink temperature feedback. This means that the fans are only running if the AC drive is running and loaded. The design of the heatsinks is such that the fan does not blow the cooling air through the interior of the AC drive, but only across the outer surface of the heat-sink. However, running fans will always attract dust. Depending on the environment the fan and the heat-sink will collect dust. Check this and clean the heatsink and the fans when necessary.

If AC drives are built into cabinets, also check and clean the dust filters of the cabinets regularly.

Check external wiring, connections and control signals. Tighten terminal screws if necessary.

13. Options

The standard options available are described here briefly. Some of the options have their own instruction or installation manual. For more information please contact your supplier.

13.1 Options for the control panel

| Part number | Description |
|-------------|--|
| 01-3957-00 | Panel kit complete including panel |
| 01-3957-01 | Panel kit complete including blank panel |

Mounting cassette, blank panel and straight RS232-cable are available as options for the control panel. These options may be useful, for example for mounting a control panel in a cabinet door.

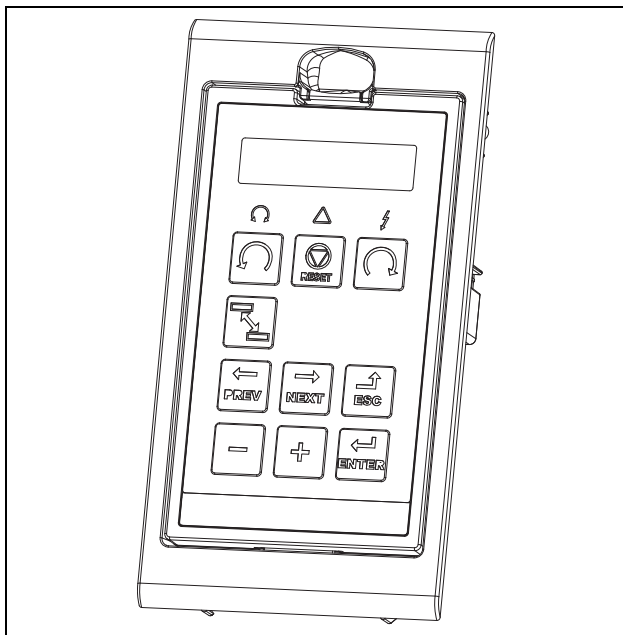

Fig. 117 Control panel in mounting cassette

13.2 Handheld Control Panel 2.0

| Part number | Description |
|-------------|--|
| 01-5039-00 | Handheld Control Panel 2.0 complete for F33/V33 2.0 or CDU/CDX 2.0 |



The Handheld Control Panel - HCP 2.0 is a complete control panel, easy to connect to the AC drive, for temporary use when e.g. commissioning, servicing and so on.

The HCP has full functionality including memory. It is possible to set parameters, view signals, actual values, fault logger information and so on. It is also possible to use the memory to copy all data (such as parameter set data and motor data) from one AC drive to the HCP and then load this data to other AC drives

13.3 EmoSoftCom

EmoSoftCom is an optional software that runs on a personal computer. It can also be used to load parameter settings from the AC drive to the PC for backup and printing. Recording can be made in oscilloscope mode. Please contact your supplier for further information.

13.4 Brake chopper

All AC drive sizes can be fitted with an optional built-in brake chopper. The brake resistor must be mounted outside the AC drive. The choice of the resistor depends on the application switch-on duration and duty-cycle. This option can not be after mounted.



WARNING!

The table gives the minimum values of the brake resistors. Do not use resistors lower than this value. The AC drive can trip or even be damaged due to high braking currents.

The following formula can be used to define the power of the connected brake resistor:

$$P_{\text{resistor}} = \frac{(\text{Brake level } V_{\text{DC}})^2}{R_{\text{min}}} \times \text{ED}$$

Where:

P_{resistor} required power of brake resistor

Brake level V_{DC} DC brake voltage level (see Table 32)

R_{min} minimum allowable brake resistor (see Table 33, Table 34 and Table 35)

ED effective braking period. Defined as:

$$\text{ED} = \frac{t_{\text{br}}}{120 \text{ [s]}}$$

t_{br} Active braking time at nominal braking power during a 2 minute operation cycle.

Maximum value of ED = 1, meaning continuous braking.

Table 32

| Supply voltage (V_{AC}) (set in menu [21B]) | Brake level (V_{DC}) |
|---|---------------------------------|
| 220-240 | 380 |
| 380-415 | 660 |
| 440-480 | 780 |
| 500-525 | 860 |
| 550-600 | 1000 |
| 660-690 | 1150 |

Table 33 Brake resistor JNVX48 type

| Type | R_{min} [ohm] if supply 380-415 V_{AC} | R_{min} [ohm] if supply 440-480 V_{AC} |
|-------------|---|---|
| JNVX48-0003 | 43 | 50 |
| -0004 | 43 | 50 |
| -0006 | 43 | 50 |
| -0008 | 43 | 50 |
| -0010 | 43 | 50 |
| -0013 | 43 | 50 |
| -0018 | 43 | 50 |
| -0026 | 26 | 30 |
| -0031 | 26 | 30 |
| -0037 | 17 | 20 |
| -046 | 17 | 20 |
| -0061 | 10 | 12 |
| -0074 | 10 | 12 |
| -0090 | 3.8 | 4.4 |
| -0109 | 3.8 | 4.4 |
| -0146 | 3.8 | 4.4 |
| -0175 | 3.8 | 4.4 |
| -0210 | 2.7 | 3.1 |
| -0250 | 2.7 | 3.1 |
| -0300 | 2 x 3.8 | 2 x 4.4 |
| -0375 | 2 x 3.8 | 2 x 4.4 |
| -0430 | 2 x 2.7 | 2 x 3.1 |
| -0500 | 2 x 2.7 | 2 x 3.1 |
| -0600 | 3 x 2.7 | 3 x 3.1 |
| -0650 | 3 x 2.7 | 3 x 3.1 |
| -0750 | 3 x 2.7 | 3 x 3.1 |
| -0860 | 4 x 2.7 | 4 x 3.1 |
| -1000 | 4 x 2.7 | 4 x 3.1 |
| -1200 | 6 x 2.7 | 6 x 3.1 |
| -1500 | 6 x 2.7 | 6 x 3.1 |

Table 34 Brake resistors JNVX52 V types

| Type | Rmin [ohm] if supply 440–480 V _{AC} | Rmin [ohm] if supply 500–525 V _{AC} |
|-------------|---|---|
| JNVX52-0003 | 50 | 55 |
| -0004 | 50 | 55 |
| -0006 | 50 | 55 |
| -0008 | 50 | 55 |
| -0010 | 50 | 55 |
| -0013 | 50 | 55 |
| -0018 | 50 | 55 |
| -0026 | 30 | 32 |
| -0031 | 30 | 32 |
| -0037 | 20 | 22 |
| -0046 | 20 | 22 |
| -0061 | 12 | 14 |
| -0074 | 12 | 14 |

Table 35 Brake resistors JNVX69 V types

| Type | Rmin [ohm] if supply 500–525 V _{AC} | Rmin [ohm] if supply 550–600 V _{AC} | Rmin [ohm] if supply 660–690 V _{AC} |
|-------------|--|--|--|
| JNVX69-0090 | 4.9 | 5.7 | 6.5 |
| -0109 | 4.9 | 5.7 | 6.5 |
| -0146 | 4.9 | 5.7 | 6.5 |
| -0175 | 4.9 | 5.7 | 6.5 |
| -0210 | 2 x 4.9 | 2 x 5.7 | 2 x 6.5 |
| -0250 | 2 x 4.9 | 2 x 5.7 | 2 x 6.5 |
| -0300 | 2 x 4.9 | 2 x 5.7 | 2 x 6.5 |
| -0375 | 2 x 4.9 | 2 x 5.7 | 2 x 6.5 |
| -0430 | 3 x 4.9 | 3 x 5.7 | 3 x 6.5 |
| -0500 | 3 x 4.9 | 3 x 5.7 | 3 x 6.5 |
| -0600 | 4 x 4.9 | 4 x 5.7 | 4 x 6.5 |
| -0650 | 4 x 4.9 | 4 x 5.7 | 4 x 6.5 |
| -0750 | 6 x 4.9 | 6 x 5.7 | 6 x 6.5 |
| -0860 | 6 x 4.9 | 6 x 5.7 | 6 x 6.5 |
| -0900 | 6 x 4.9 | 6 x 5.7 | 6 x 6.5 |
| -1000 | 6 x 4.9 | 6 x 5.7 | 6 x 6.5 |

NOTE: Although the AC drive will detect a failure in the brake electronics, the use of resistors with a thermal overload which will cut off the power at overload is strongly recommended.

The brake chopper option is built-in by the manufacturer and must be specified when the AC drive is ordered.

13.5 I/O Board

| Part number | Description |
|-------------|----------------------|
| 01-3876-01 | I/O option board 2.0 |

Each I/O option board 2.0 provides three extra relay outputs and three extra digital inputs (24V). The I/O Board works in combination with the Pump/Fan Control, but can also be used as a separate option. Maximum 3 I/O boards possible. This option is described in a separate manual.

13.6 Encoder

| Part number | Description |
|-------------|--------------------------|
| 01-3876-03 | Encoder 2.0 option board |

The Encoder 2.0 option board, used for connection of feedback signal of the actual motor speed via an incremental encoder is described in a separate manual.

13.7 PTC/PT100

| Part number | Description |
|-------------|----------------------------|
| 01-3876-08 | PTC/PT100 2.0 option board |

The PTC/PT100 2.0 option board for connecting motor thermistors and max 3 PT100 elements to the AC drive is described in a separate manual.

13.8 Crane option board

| Part number | Description |
|-------------|--|
| 590059 | Crane interface board, 230 V _{AC} |
| 590060 | Crane interface board, 24 V _{DC} |

This option is used in crane applications. The crane option board 2.0 is described in a separate manual.

13.9 Serial communication and fieldbus

| Part number | Description |
|-------------|----------------------|
| 01-3876-04 | RS232/485 |
| 01-3876-05 | Profibus DP |
| 01-3876-06 | DeviceNet |
| 01-3876-09 | Modbus/TCP, Ethernet |

For communication with the AC drive there are several option boards for communication. There are different options for Fieldbus communication and one serial communication option with RS232 or RS485 interface which has galvanic isolation.

13.10 Standby supply board option

| Part number | Description |
|-------------|---|
| 01-3954-00 | Standby power supply kit for after mounting |

The standby supply board option provides the possibility of keeping the communication system up and running without having the 3-phase mains connected. One advantage is that the system can be set up without mains power. The option will also give backup for communication failure if main power is lost.

The standby supply board option is supplied with external $\pm 10\%$ 24 V_{DC} protected by a 2 A slow acting fuse, from a double isolated transformer. The terminals X1:1, X1:2 (on size B,C and E to F) are voltage polarity independent.

The terminals A and B (on size D) are voltage polarity dependent.

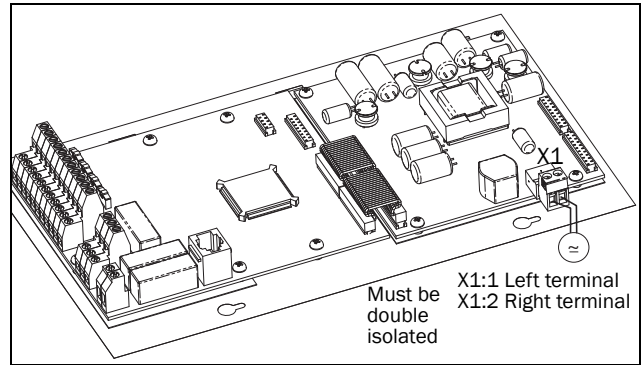

Fig. 118 Connection of standby supply option on size B,C and E-F

| X1 terminal | Name | Function | Specification |
|-------------|---------------|--|--|
| 1 | Ext. supply 1 | External, AC drive main power independent, supply voltage for control and communication circuits | 24 V _{DC} $\pm 10\%$ Double isolated |
| 2 | Ext. supply 2 | | |

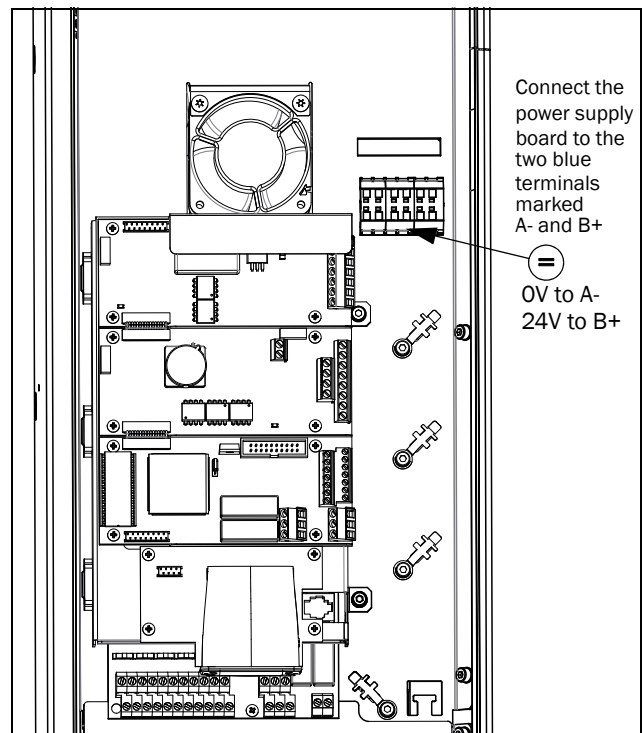

Fig. 119 Connection of standby supply option on size D

| Terminal | Name | Function | Specification |
|----------|------|--|--|
| A - | 0V | External, AC drive main power dependent, supply voltage for control and communication circuits | 24 V _{DC} $\pm 10\%$ Double isolated |
| B + | +24V | | |

13.11 Safe Stop option

To realize a Safe Stop configuration in accordance with Safe Torque Off (STO) EN-IEC 62061:2005 SIL 2 & EN-ISO 13849-1:2006, the following three parts need to be attended to:

1. Inhibit trigger signals with safety relay K1 (via Safe Stop option board).
2. Enable input and control of AC drive (via normal I/O control signals of AC drive).
3. Power conductor stage (checking status and feedback of driver circuits and IGBT's).

To enable the AC drive to operate and run the motor, the following signals should be active:

- "Inhibit" input, terminals 1 (DC+) and 2 (DC-) on the Safe Stop option board should be made active by connecting 24 V_{DC} to secure the supply voltage for the driver circuits of the power conductors via safety relay K1. See also Fig. 122.
- High signal on the digital input, e.g. terminal 10 in Fig. 122, which is set to "Enable". For setting the digital input please refer to section 11.5.2, page 130.

These two signals need to be combined and used to enable the output of the AC drive and make it possible to activate a Safe Stop condition.

NOTE: The "Safe Stop" condition according to EN-IEC 62061:2005 SIL 2 & EN-ISO 13849-1:2006, can only be realized by de-activating both the "Inhibit" and "Enable" inputs.

When the "Safe Stop" condition is achieved by using these two different methods, which are independently controlled, this safety circuit ensures that the motor will not start running because:

- The 24VDC signal is disconnected from the "Inhibit" input, terminals 1 and 2, the safety relay K1 is switched off.

The supply voltage to the driver circuits of the power conductors is switched off. This will inhibit the trigger pulses to the power conductors.

- The trigger pulses from the control board are shut down.

The Enable signal is monitored by the controller circuit which will forward the information to the PWM part on the Control board.

To make sure that the safety relay K1 has been switched off, this should be guarded externally to ensure that this relay did not refuse to act. The Safe Stop option board offers a feedback signal for this via a second forced switched safety relay K2 which is switched on when a detection circuit has confirmed that the supply voltage to the driver circuits is shut down. See Table 36 for the contacts connections.

To monitor the "Enable" function, the selection "RUN" on a digital output can be used. For setting a digital output, e.g. terminal 20 in the example Fig. 122, please refer to section 11.5.4, page 136 [540].

When the "Inhibit" input is de-activated, the AC drive display will show a flashing "SST" indication in section D (bottom left corner) and the red Trip LED on the Control panel will be flashing.

To resume normal operation, the following steps have to be taken:

- Release "Inhibit" input; 24V_{DC} (High) to terminal 1 and 2.
- Give a STOP signal to the AC drive, according to the set Run/Stop Control in menu [215].
- Give a new Run command, according to the set Run/Stop Control in menu [215].

NOTE: The method of generating a STOP command is dependent on the selections made in Start Signal Level/Edge [21A] and the use of a separate Stop input via digital input.



WARNING!

The safe stop function can never be used for electrical maintenance. For electrical maintenance the AC drive should always be disconnected from the supply voltage.

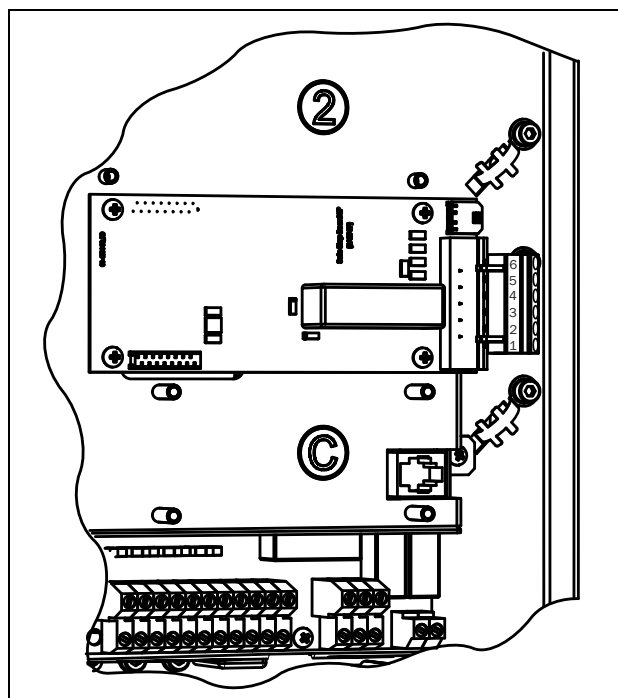

Fig. 120 Connection of safe stop option in size B - D.

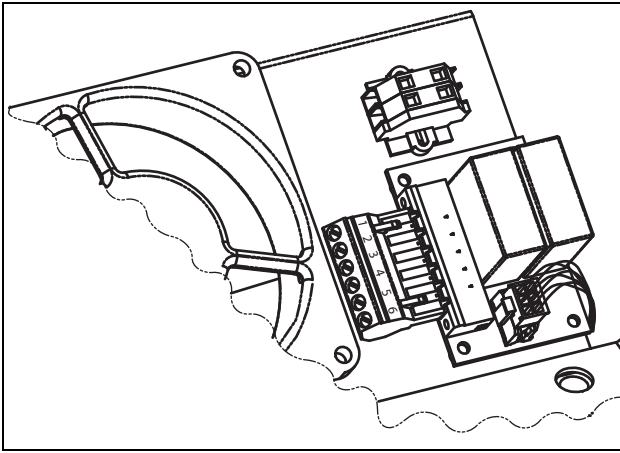

Fig. 121 Connection of safe stop option in size E and up.

Table 36 Specification of Safe Stop option board

| X1 pin | Name | Function | Specification |
|--------|---------------------|--|---|
| 1 | Inhibit + | Inhibit driver circuits of power conductors | DC 24 V (20–30 V) |
| 2 | Inhibit - | | |
| 3 | NO contact relay K2 | Feedback; confirmation of activated inhibit | 48 V _{DC} / 30 V _{AC} /2 A |
| 4 | P contact relay K2 | | |
| 5 | GND | Supply ground | |
| 6 | +24 VDC | Supply Voltage for operating Inhibit input only. | +24 V _{DC} , 50 mA |

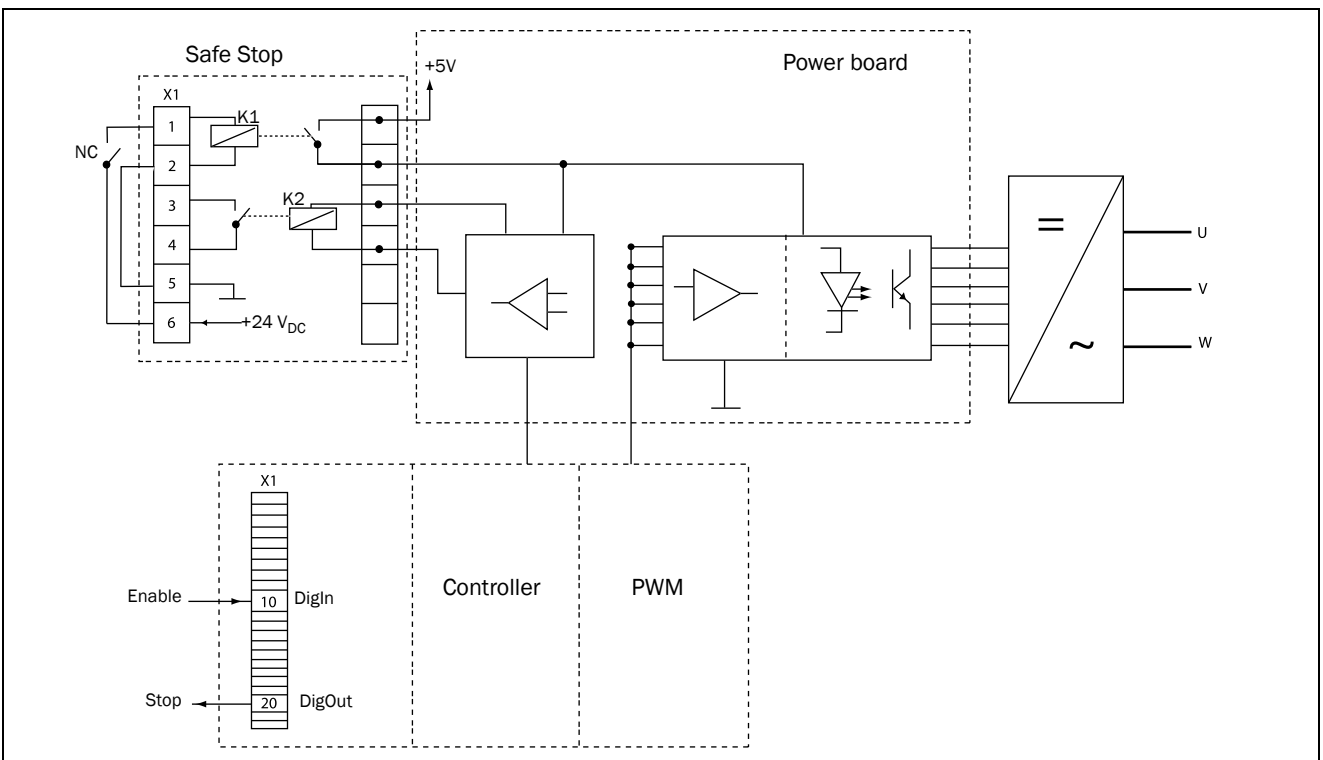

Fig. 122

13.12 Output chokes

Output chokes, which are supplied separately, are recommended for lengths of screened motor cable longer than 100 m. Because of the fast switching of the motor voltage and the capacitance of the motor cable (both line to line and line to earth screen), large switching currents can be generated with long lengths of motor cable. Output chokes prevent the AC drive from tripping and should be installed as closely as possible to the AC drive.

13.13 Liquid cooling

AC drive modules in frame sizes E - K and F69 - K69 are available in a liquid cooled version. These units are designed for connection to a liquid cooling system, normally a heat exchanger of liquid-liquid or liquid-air type. Heat exchanger is not part of the liquid cooling option. Drive units with parallel power modules (frame size G - K69) are delivered with a dividing unit for connection of the cooling liquid. The drive units are equipped with rubber hoses with leak-proof quick couplings. The Liquid cooling option is described in a separate manual

14. Technical Data

14.1 Electrical specifications related to model

Table 37 Typical motor power at mains voltage 400 V

| Model | Max. output current [A]* | Normal duty (120%, 1 min every 10 min) | | Heavy duty (150%, 1 min every 10 min) | | Frame size |
|-------------|--------------------------|---|-------------------|--|-------------------|------------|
| | | Power @400V [kW] | Rated current [A] | Power @400V [kW] | Rated current [A] | |
| JNVX48-0003 | 3.8 | 0.75 | 2.5 | 0.55 | 2.0 | B |
| JNVX48-0004 | 6.0 | 1.5 | 4.0 | 1.1 | 3.2 | |
| JNVX48-0006 | 9.0 | 2.2 | 6.0 | 1.5 | 4.8 | |
| JNVX48-0008 | 11.3 | 3 | 7.5 | 2.2 | 6.0 | |
| JNVX48-0010 | 14.3 | 4 | 9.5 | 3 | 7.6 | |
| JNVX48-0013 | 19.5 | 5.5 | 13.0 | 4 | 10.4 | |
| JNVX48-0018 | 27.0 | 7.5 | 18.0 | 5.5 | 14.4 | |
| JNVX48-0026 | 39 | 11 | 26 | 7.5 | 21 | C |
| JNVX48-0031 | 46 | 15 | 31 | 11 | 25 | |
| JNVX48-0037 | 55 | 18.5 | 37 | 15 | 29.6 | |
| JNVX48-0046 | 69 | 22 | 46 | 18.5 | 37 | |
| JNVX48-0061 | 92 | 30 | 61 | 22 | 49 | D |
| JNVX48-0074 | 111 | 37 | 74 | 30 | 59 | |
| JNVX48-0090 | 108 | 45 | 90 | 37 | 72 | E |
| JNVX48-0109 | 131 | 55 | 109 | 45 | 87 | |
| JNVX48-0146 | 175 | 75 | 146 | 55 | 117 | |
| JNVX48-0175 | 210 | 90 | 175 | 75 | 140 | |
| JNVX48-0210 | 252 | 110 | 210 | 90 | 168 | F |
| JNVX48-0228 | 300 | 110 | 228 | 90 | 182 | |
| JNVX48-0250 | 300 | 132 | 250 | 110 | 200 | |
| JNVX48-0300 | 360 | 160 | 300 | 132 | 240 | G |
| JNVX48-0375 | 450 | 200 | 375 | 160 | 300 | |
| JNVX48-0430 | 516 | 220 | 430 | 200 | 344 | H |
| JNVX48-0500 | 600 | 250 | 500 | 220 | 400 | |
| JNVX48-0600 | 720 | 315 | 600 | 250 | 480 | I |
| JNVX48-0650 | 780 | 355 | 650 | 315 | 520 | |
| JNVX48-0750 | 900 | 400 | 750 | 355 | 600 | |
| JNVX48-0860 | 1032 | 450 | 860 | 400 | 688 | J |
| JNVX48-1000 | 1200 | 500 | 1000 | 450 | 800 | |
| JNVX48-1200 | 1440 | 630 | 1200 | 500 | 960 | K |
| JNVX48-1500 | 1800 | 800 | 1500 | 630 | 1200 | |

* Available during limited time and as long as allowed by drive temperature.

Table 38 Typical motor power at mains voltage 460 V

| Model | Max. output current [A]* | Normal duty (120%, 1 min every 10 min) | | Heavy duty (150%, 1 min every 10 min) | | Frame size |
|-------------|--------------------------|---|-------------------|--|-------------------|------------|
| | | Power @460V [hp] | Rated current [A] | Power @460V [hp] | Rated current [A] | |
| JNVX48-0003 | 3.8 | 1 | 2.5 | 1 | 2.0 | B |
| JNVX48-0004 | 6.0 | 2 | 4.0 | 1.5 | 3.2 | |
| JNVX48-0006 | 9.0 | 3 | 6.0 | 2 | 4.8 | |
| JNVX48-0008 | 11.3 | 3 | 7.5 | 3 | 6.0 | |
| JNVX48-0010 | 14.3 | 5 | 9.5 | 3 | 7.6 | |
| JNVX48-0013 | 19.5 | 7.5 | 13.0 | 5 | 10.4 | |
| JNVX48-0018 | 27.0 | 10 | 18.0 | 7.5 | 14.4 | |
| JNVX48-0026 | 39 | 15 | 26 | 10 | 21 | C |
| JNVX48-0031 | 46 | 20 | 31 | 15 | 25 | |
| JNVX48-0037 | 55 | 25 | 37 | 20 | 29.6 | |
| JNVX48-0046 | 69 | 30 | 46 | 25 | 37 | |
| JNVX48-0061 | 92 | 40 | 61 | 30 | 49 | D |
| JNVX48-0074 | 111 | 50 | 74 | 40 | 59 | |
| JNVX48-0090 | 108 | 60 | 90 | 50 | 72 | E |
| JNVX48-0109 | 131 | 75 | 109 | 60 | 87 | |
| JNVX48-0146 | 175 | 100 | 146 | 75 | 117 | |
| JNVX48-0175 | 210 | 125 | 175 | 100 | 140 | |
| JNVX48-0210 | 252 | 150 | 210 | 125 | 168 | F |
| JNVX48-0228 | 300 | 200 | 228 | 150 | 182 | |
| JNVX48-0250 | 300 | 200 | 250 | 150 | 200 | |
| JNVX48-0300 | 360 | 250 | 300 | 200 | 240 | G |
| JNVX48-0375 | 450 | 300 | 375 | 250 | 300 | |
| JNVX48-0430 | 516 | 350 | 430 | 250 | 344 | H |
| JNVX48-0500 | 600 | 400 | 500 | 350 | 400 | |
| JNVX48-0600 | 720 | 500 | 600 | 400 | 480 | I |
| JNVX48-0650 | 780 | 550 | 650 | 400 | 520 | |
| JNVX48-0750 | 900 | 600 | 750 | 500 | 600 | |
| JNVX48-0860 | 1032 | 700 | 860 | 550 | 688 | J |
| JNVX48-1000 | 1200 | 800 | 1000 | 650 | 800 | |
| JNVX48-1200 | 1440 | 1000 | 1200 | 800 | 960 | K |
| JNVX48-1500 | 1800 | 1250 | 1500 | 1000 | 1200 | |

* Available during limited time and as long as allowed by drive temperature.

Table 39 Typical motor power at mains voltage 525 V

| Model | Max. output current [A]* | Normal duty (120%, 1 min every 10 min) | | Heavy duty (150%, 1 min every 10 min) | | Frame size |
|-------------|--------------------------|---|-------------------|--|-------------------|------------|
| | | Power @525V [kW] | Rated current [A] | Power @525V [kW] | Rated current [A] | |
| JNVX52-0003 | 3.8 | 1.1 | 2.5 | 1.1 | 2.0 | B |
| JNVX52-0004 | 6.0 | 2.2 | 4.0 | 1.5 | 3.2 | |
| JNVX52-0006 | 9.0 | 3 | 6.0 | 2.2 | 4.8 | |
| JNVX52-0008 | 11.3 | 4 | 7.5 | 3 | 6.0 | |
| JNVX52-0010 | 14.3 | 5.5 | 9.5 | 4 | 7.6 | |
| JNVX52-0013 | 19.5 | 7.5 | 13.0 | 5.5 | 10.4 | |
| JNVX52-0018 | 27.0 | 11 | 18.0 | 7.5 | 14.4 | |
| JNVX52-0026 | 39 | 15 | 26 | 11 | 21 | C |
| JNVX52-0031 | 46 | 18.5 | 31 | 15 | 25 | |
| JNVX52-0037 | 55 | 22 | 37 | 18.5 | 29.6 | |
| JNVX52-0046 | 69 | 30 | 46 | 22 | 37 | |
| JNVX52-0061 | 92 | 37 | 61 | 30 | 49 | D |
| JNVX52-0074 | 111 | 45 | 74 | 37 | 59 | |
| JNVX69-0090 | 108 | 55 | 90 | 45 | 72 | F69 |
| JNVX69-0109 | 131 | 75 | 109 | 55 | 87 | |
| JNVX69-0146 | 175 | 90 | 146 | 75 | 117 | |
| JNVX69-0175 | 210 | 110 | 175 | 90 | 140 | |
| JNVX69-0210 | 252 | 132 | 210 | 110 | 168 | H69 |
| JNVX69-0250 | 300 | 160 | 250 | 132 | 200 | |
| JNVX69-0300 | 360 | 200 | 300 | 160 | 240 | |
| JNVX69-0375 | 450 | 250 | 375 | 200 | 300 | |
| JNVX69-0430 | 516 | 300 | 430 | 250 | 344 | I69 |
| JNVX69-0500 | 600 | 315 | 500 | 300 | 400 | |
| JNVX69-0600 | 720 | 400 | 600 | 315 | 480 | J69 |
| JNVX690-650 | 780 | 450 | 650 | 355 | 520 | |
| JNVX69-0750 | 900 | 500 | 750 | 400 | 600 | K69 |
| JNVX69-0860 | 1032 | 560 | 860 | 450 | 688 | |
| JNVX69-1000 | 1200 | 630 | 1000 | 500 | 800 | |

* Available during limited time and as long as allowed by drive temperature.

Table 40 Typical motor power at mains voltage 575 V

| Model | Max. output current [A]* | Normal duty (120%, 1 min every 10 min) | | Heavy duty (150%, 1 min every 10 min) | | Frame size |
|-------------|--------------------------|---|-------------------|--|-------------------|------------|
| | | Power @575V [hp] | Rated current [A] | Power @575V [hp] | Rated current [A] | |
| JNVX69-0090 | 108 | 75 | 90 | 60 | 72 | F69 |
| JNVX69-0109 | 131 | 100 | 109 | 75 | 87 | |
| JNVX69-0146 | 175 | 125 | 146 | 100 | 117 | |
| JNVX69-0175 | 210 | 150 | 175 | 125 | 140 | |
| JNVX69-0210 | 252 | 200 | 210 | 150 | 168 | H69 |
| JNVX69-0250 | 300 | 250 | 250 | 200 | 200 | |
| JNVX69-0300 | 360 | 300 | 300 | 250 | 240 | |
| JNVX69-0375 | 450 | 350 | 375 | 300 | 300 | |
| JNVX69-0430 | 516 | 400 | 430 | 350 | 344 | I69 |
| JNVX69-0500 | 600 | 500 | 500 | 400 | 400 | |
| JNVX69-0600 | 720 | 600 | 600 | 500 | 480 | J69 |
| JNVX69-0650 | 780 | 650 | 650 | 550 | 520 | |
| JNVX69-0750 | 900 | 750 | 750 | 600 | 600 | K69 |
| JNVX69-0860 | 1032 | 850 | 860 | 700 | 688 | |
| JNVX69-1000 | 1200 | 1000 | 1000 | 850 | 800 | |

* Available during limited time and as long as allowed by drive temperature.

Table 41 Typical motor power at mains voltage 690 V

| Model | Max. output current [A]* | Normal duty (120%, 1 min every 10 min) | | Heavy duty (150%, 1 min every 10 min) | | Frame size |
|-------------|--------------------------|---|-------------------|--|-------------------|------------|
| | | Power @690V [kW] | Rated current [A] | Power @690V [kW] | Rated current [A] | |
| JNVX69-0090 | 108 | 90 | 90 | 75 | 72 | F69 |
| JNVX69-0109 | 131 | 110 | 109 | 90 | 87 | |
| JNVX69-0146 | 175 | 132 | 146 | 110 | 117 | |
| JNVX69-0175 | 210 | 160 | 175 | 132 | 140 | |
| JNVX69-0210 | 252 | 200 | 210 | 160 | 168 | H69 |
| JNVX69-0250 | 300 | 250 | 250 | 200 | 200 | |
| JNVX69-0300 | 360 | 315 | 300 | 250 | 240 | |
| JNVX69-0375 | 450 | 355 | 375 | 315 | 300 | |
| JNVX69-0430 | 516 | 450 | 430 | 315 | 344 | I69 |
| JNVX69-0500 | 600 | 500 | 500 | 355 | 400 | |
| JNVX69-0600 | 720 | 600 | 600 | 450 | 480 | J69 |
| JNVX69-0650 | 780 | 630 | 650 | 500 | 520 | |
| JNVX69-0750 | 900 | 710 | 750 | 600 | 600 | K69 |
| JNVX69-0860 | 1032 | 800 | 860 | 650 | 688 | |
| JNVX69-0900 | 1080 | 900 | 900 | 710 | 720 | |
| JNVX69-1000 | 1200 | 1000 | 1000 | 800 | 800 | |

* Available during limited time and as long as allowed by drive temperature.

14.2 General electrical specifications

Table 42 General electrical specifications

| General | |
|--|--|
| Mains voltage: JNVX48 JNVX52 JNVX69 | 230-480V +10%/-15% (-10% at 230 V) 440-525 V +10 %/-15 % 500-690V +10%/-15% |
| Mains frequency: | 45 to 65 Hz |
| Input power factor: | 0.95 |
| Output voltage: | 0-Mains supply voltage: |
| Output frequency: | 0-400 Hz |
| Output switching frequency: | 3 kHz |
| Efficiency at nominal load: | 97% for models 0003 to 0018 98% for models 0026 to 1500 |
| Control signal inputs: | |
| Analogue (differential) | |
| Analogue Voltage/current: Max. input voltage: Input impedance: | 0-±10 V/0-20 mA via switch +30 V/30 mA 20 kΩ (voltage) 250 Ω (current) |
| Resolution: Hardware accuracy: Non-linearity | 11 bits + sign 1% type + 1 ½ LSB fsd 1½ LSB |
| Digital: | |
| Input voltage: Max. input voltage: Input impedance: | High: >9 VDC, Low: <4 VDC +30 VDC <3.3 VDC: 4.7 kΩ ≥3.3 VDC: 3.6 kΩ |
| Signal delay: | ≤8 ms |
| Control signal outputs | |
| Analogue | |
| Output voltage/current: Max. output voltage: Short-circuit current (∞): Output impedance: | 0-10 V/0-20 mA via software setting +15 V @5 mA cont. +15 mA (voltage), +140 mA (current) 10 Ω (voltage) |
| Resolution: Maximum load impedance for current Hardware accuracy: Offset: Non-linearity: | 10 bit 500 Ω 1.9% type fsd (voltage), 2.4% type fsd (current) 3 LSB 2 LSB |
| Digital | |
| Output voltage: Shortcircuit current(∞): | High: >20 VDC @50 mA, >23 VDC open Low: <1 VDC @50 mA 100 mA max (together with +24 VDC) |
| Relays | |
| Contacts | 0.1 – 2 A/U _{max} 250 VAC or 42 VDC |
| References | |
| +10VDC -10VDC +24VDC | +10 V _{DC} @10 mA Short-circuit current +30 mA max -10 V _{DC} @10 mA +24 V _{DC} Short-circuit current +100 mA max (together with Digital Outputs) |

14.3 Operation at higher temperatures

Most AC drives are made for operation at maximum of 40 °C ambient temperature. However, for most models, it is possible to use the AC drive at higher temperatures with little loss in performance. Table 43 shows ambient temperatures as well as derating for higher temperatures.

Table 43 Ambient temperature and derating 400–690 V types

| Model | IP20 | | IP54 | |
|--|-----------|-----------------------|-----------|------------------------|
| | Max temp. | Derating: possible | Max temp. | Derating: possible |
| JNVX**-0003 to JNVX**-0074 | – | – | 40 °C | -2.5%/°C to max +10 °C |
| JNVX48-0090 to JNVX48-0250 JNVX69-0090 to JNVX69-0175 | – | – | 40 °C | -2.5%/°C to max +5 °C |
| JNVX48-0300 to JNVX48-1500 JNVX69-0210 to JNVX69-1000 | 40 °C | -2.5%/°C to max +5 °C | 40 °C | -2.5%/°C to max +5 °C |

Example

In this example we have a motor with the following data that we want to run at the ambient temperature of 45 °C:

Voltage 400 V
Current 68 A
Power 37 kW

Select AC drive

The ambient temperature is 5 °C higher than the maximum ambient temperature. The following calculation is made to select the correct AC drive model.

Derating is possible with loss in performance of 2.5%/°C.

Derating will be: $5 \times 2.5\% = 12.5\%$

Calculation for model JNVX48-0031

$31 \text{ A} - (12.5\% \times 31) = 27.1 \text{ A}$; this is not enough.

Calculation for model JNVX48-0037

$37 \text{ A} - (12.5\% \times 37) = 32.4 \text{ A}$

In this example we select the JNVX48-0037.

14.4 Dimensions and Weights

The table below gives an overview of the dimensions and weights. The models 003 to 250 is available in IP54 as wall mounted modules. The models 300 to 1500 consist of 2, 3, 4 or 6 paralleled power electronic building block (PEBB) available in IP20 as wall mounted modules and in IP54 mounted standard cabinet

Protection class IP54 is according to the EN 60529 standard.

Table 44 Mechanical specifications, JNVX48, JNVX52

| Models | Frame size | Dim. H x W x D [mm] IP20 | Dim. H x W x D [mm] IP54 | Weight IP20 [kg] | Weight IP54 [kg] |
|--------------|------------|-----------------------------|-----------------------------|------------------|------------------|
| 0003 to 0018 | B | - | 350(416)x 203 x 200 | - | 12.5 |
| 0026 to 0046 | C | - | 440(512) x 178 x 292 | - | 24 |
| 0061 to 0074 | D | - | 545(590) x 220 x 295 | - | 32 |
| 0090 to 0109 | E | - | 950 x 285 x 314 | - | 56 |
| 0146 to 0175 | E | - | 950 x 285 x 314 | - | 60 |
| 0210 to 0250 | F | - | 950 x 345 x 314 | - | 74 |
| 0300 to 0375 | G | 1036 x 500 x 390 | 2330 x 600 x 500 | 140 | 270 |
| 0430 to 0500 | H | 1036 x 500 x 450 | 2330 x 600 x 600 | 170 | 305 |
| 0600 to 0750 | I | 1036 x 730 x 450 | 2330 x 1000 x 600 | 248 | 440 |
| 0860 to 1000 | J | 1036 x 1100 x 450 | 2330 x 1200 x 600 | 340 | 580 |
| 1200 to 1500 | K | 1036 x 1560 x 450 | 2330 x 2000 x 600 | 496 | 860 |

Table 45 Mechanical specifications, JNVX69

| Models | Frame size | Dim. H x W x D [mm] IP20 | Dim. H x W x D [mm] IP54 | Weight IP20 [kg] | Weight IP54 [kg] |
|--------------|------------|-----------------------------|-----------------------------|------------------|------------------|
| 0090 to 0175 | F69 | - | 1090 x 345 x 314 | - | 77 |
| 0210 to 0375 | H69 | 1176 x 500 x 450 | 2330 x 600 x 600 | 176 | 311 |
| 0430 to 0500 | I69 | 1176 x 730 x 450 | 2330 x 1000 x 600 | 257 | 449 |
| 0600 to 0650 | J69 | 1176 x 1100 x 450 | 2330 x 1200 x 600 | 352 | 592 |
| 0750 to 1000 | K69 | 1176 x 1560 x 450 | 2330 x 2000 x 600 | 514 | 878 |

14.5 Environmental conditions

Table 46 Operation

| Parameter | Normal operation |
|---|--|
| Nominal ambient temperature | 0°C–40°C See table, see Table 43 for different conditions |
| Atmospheric pressure | 86–106 kPa |
| Relative humidity, non-condensing | 0–90% |
| Contamination, according to IEC 60721-3-3 | No electrically conductive dust allowed. Cooling air must be clean and free from corrosive materials. Chemical gases, class 3C2. Solid particles, class 3S2. |
| Vibrations | According to IEC 60068-2-6, Sinusoidal vibrations: 10<f<57 Hz, 0.075 mm 57<f<150 Hz, 1g |
| Altitude | 0–1000 m 480V AC drives, with derating 1%/100 m of rated current up to 4000 m 690V AC drives, with derating 1%/100 m of rated current up to 2000 m |

Table 47 Storage

| Parameter | Storage condition |
|-----------------------------------|-------------------|
| Temperature | -20 to +60 °C |
| Atmospheric pressure | 86–106 kPa |
| Relative humidity, non-condensing | 0– 90% |

14.6 Fuses, cable cross-sections and glands

NOTE: The dimensions of fuse and cable cross-section are dependent on the application and must be determined in accordance with local regulations.

14.6.1 According IEC ratings

Use mains fuses of the type gL/gG conforming to IEC 269 or installation cut-outs with similar characteristics. Check the equipment first before installing the glands.

Max. Fuse = maximum fuse value that still protects the AC drive and upholds warranty.

NOTE: The dimensions of the power terminals used in the models 300 to 1500 can differ depending on customer specification.

Table 48 Fuses, cable cross-sections and glands

| Model | Nominal input current [A] | Maximum value fuse [A] | Cable cross section connector range [mm ²] for | | | Cable glands (clamping range [mm]) | |
|-------------|---------------------------|------------------------|--|---------------------------------|---|--|--|
| | | | mains/ motor | Brake | PE | mains / motor | Brake |
| JNVX**-0003 | 2.2 | 4 | 0.5-10 | 0.5-10 | 1.5-16 | M32 opening M20 + reducer (6-12) | M25 opening M20 + reducer (6-12) |
| JNVX**-0004 | 3.5 | 4 | | | | | |
| JNVX**-0006 | 5.2 | 6 | | | | | |
| JNVX**-0008 | 6.9 | 8 | | | | M32 (12-20)/ M32 opening M25+reducer (10-14) | M25 (10-14) |
| JNVX**-0010 | 8.7 | 10 | | | | | |
| JNVX**-0013 | 11.3 | 16 | | | | | |
| JNVX**-0018 | 15.6 | 20 | 2.5 - 16 stranded wire 2.5 - 25 solid wire | 6 - 35 | M32 (15-21) | M25 | |
| JNVX**-0026 | 22 | 25 | | | | | |
| JNVX**-0031 | 26 | 35 | | | | | |
| JNVX**-0037 | 31 | 35 | | | M40 (19-28) | M32 | |
| JNVX**-0046 | 38 | 50 | | | | | |
| JNVX**-0061 | 52 | 63 | | | | | |
| JNVX**-0074 | 65 | 80 | 1 - 35 stranded wire 1 - 50 solid wire | | | M50 (27 - 35) | M40 (19 - 28) |
| JNVX**-0090 | 78 | 100 | 16 - 95 | 16 - 95 | 16-95 (16-70) ¹ | JNVX48: Ø17-42 cable flexible leadthrough or M50 opening. JNVX69: Ø23-55 Cable flexible leadthrough or M63 opening. | FX48: Ø11-32 Cable flexible leadthrough or M40 opening. JNVX69: Ø17-42 Cable flexible leadthrough or M50 opening. |
| JNVX**-0109 | 94 | 100 | | | | | |
| JNVX**-0146 | 126 | 160 | 35 - 150 | 16 - 95 | 35-150 (16-70) ¹ | | |
| JNVX**-0175 | 152 | 160 | | | | | |
| JNVX**-0210 | 182 | 200 | JNVX48: 35-250 JNVX69: 35-150 | JNVX48: 35-150 JNVX69: 16-95 | JNVX48: 35-250 (95-185) ¹ JNVX69: 35-150 (16-70) ¹ | Ø23-55 cable flexible leadthrough or M63 opening. | Ø17-42 cable flexible leadthrough or M50 opening. |
| JNVX**-0228 | 216 | 250 | | | | | |
| JNVX**-0250 | | | | | | | |
| JNVX**-0300 | 260 | 300 | JNVX48: (2x)35-240 JNVX69: (2x)35-150 | | | frame | -- |
| JNVX**-0375 | 324 | 355 | | | | | -- |

Table 48 Fuses, cable cross-sections and glands

| Model | Nominal input current [A] | Maximum value fuse [A] | Cable cross section connector range [mm ²] for | | | Cable glands (clamping range [mm]) | |
|-------------|---------------------------|------------------------|--|-------|-------|------------------------------------|-------|
| | | | mains/ motor | Brake | PE | mains / motor | Brake |
| JNVX**-0430 | 372 | 400 | JNVX48: (2x)35-240 JNVX69: (3x)35-150 | | frame | -- | -- |
| JNVX**-0500 | 432 | 500 | | | | | |
| JNVX**-0600 | 520 | 630 | JNVX48: (3x)35-240 JNVX69: (4x)35-150 | | frame | -- | -- |
| JNVX**-0650 | 562 | 630 | | | | | |
| JNVX**-0750 | 648 | 710 | JNVX48: (3x)35-240 JNVX69: (6x)35-150 | | frame | -- | -- |
| JNVX**-0860 | 744 | 800 | JNVX48: (4x)35-240 JNVX69: (6x)35-150 | | frame | -- | -- |
| JNVX**-0900 | 795 | 900 | | | | | |
| JNVX**-1000 | 864 | 1000 | | | | | |
| JNVX**-1200 | 1037 | 1250 | JNVX48: (6x)35-240 | | frame | -- | -- |
| JNVX**-1500 | 1296 | 1500 | | | | | |

Note: For models 0003 to 0074 cable glands are optional.

1. Values are valid when brake chopper electronics are built in.

14.6.2 Fuses and cable dimensions according to NEMA ratings

Table 49 Types and fuses

| Model | Input current [Arms] | Mains input fuses | |
|-------------|----------------------|-------------------|---------------------|
| | | UL Class J TD (A) | Ferraz-Shawmut type |
| JNVX48-0003 | 2,2 | 6 | AJT6 |
| JNVX48-0004 | 3,5 | 6 | AJT6 |
| JNVX48-0006 | 5,2 | 6 | AJT6 |
| JNVX48-0008 | 6,9 | 10 | AJT10 |
| JNVX48-0010 | 8,7 | 10 | AJT10 |
| JNVX48-0013 | 11,3 | 15 | AJT15 |
| JNVX48-0018 | 15,6 | 20 | AJT20 |
| JNVX48-0026 | 22 | 25 | AJT25 |
| JNVX48-0031 | 26 | 30 | AJT30 |
| JNVX48-0037 | 31 | 35 | AJT35 |
| JNVX48-0046 | 38 | 45 | AJT45 |
| JNVX48-0061 | 52 | 60 | AJT60 |
| JNVX48-0074 | 65 | 80 | AJT80 |
| JNVX48-0090 | 78 | 100 | AJT100 |
| JNVX48-0109 | 94 | 110 | AJT110 |
| JNVX48-0146 | 126 | 150 | AJT150 |
| JNVX48-0175 | 152 | 175 | AJT175 |
| JNVX48-0210 | 182 | 200 | AJT200 |
| JNVX48-0228 | 216 | 250 | AJT250 |
| JNVX48-0250 | 216 | 250 | AJT250 |
| JNVX48-0300 | 260 | 300 | AJT300 |
| JNVX48-0375 | 324 | 350 | AJT350 |
| JNVX48-0430 | 372 | 400 | AJT400 |
| JNVX48-0500 | 432 | 500 | AJT500 |
| JNVX48-0600 | 520 | 600 | AJT600 |
| JNVX48-0650 | 562 | 600 | AJT600 |
| JNVX48-0750 | 648 | 700 | A4BQ700 |
| JNVX48-0860 | 744 | 800 | A4BQ800 |
| JNVX48-1000 | 864 | 1000 | A4BQ1000 |
| JNVX48-1200 | 1037 | 1200 | A4BQ1200 |
| JNVX48-1500 | 1296 | 1500 | A4BQ1500 |

Table 50 Type cables cross-sections and glands

| Model | Cable cross section connector | | | | | | Cable type |
|-------------|-------------------------------|--------------------------------|----------------|--------------------------------|----------------|--------------------------------|--|
| | Mains and motor | | Brake | | PE | | |
| | Range | Tightening torque Nm/ft lbf | Range | Tightening torque Nm/ft lbf | Range | Tightening torque Nm/ft lbf | |
| JNVX48-0003 | AWG 20 - AWG 6 | 1.3 / 1 | AWG 20 - AWG 6 | 1.3 / 1 | AWG 14 - AWG 6 | 2.6/2 | Copper (Cu) 60 °C |
| JNVX48-0004 | | | | | | | |
| JNVX48-0006 | | | | | | | |
| JNVX48-0008 | | | | | | | |
| JNVX48-0010 | | | | | | | |
| JNVX48-0013 | | | | | | | |
| JNVX48-0018 | | | | | | | |
| JNVX48-0019 | | | | | | | |
| JNVX48-0026 | AWG 12 - AWG 4 | 1.3 / 1 | AWG 12 - AWG 4 | 1.3 / 1 | AWG 8 - AWG 2 | 2.6 / 2 | output current <44A: Copper (Cu) 60 °C output current >44A: Copper (Cu) 75 °C |
| JNVX48-0031 | | | | | | | |
| JNVX48-0037 | | | | | | | |
| JNVX48-0046 | | | | | | | |

Table 50 Type cables cross-sections and glands

| Model | Cable cross section connector | | | | | | Cable type |
|-------------|--|-----------------------------|--|-----------------------------|---|--------------------------------------|----------------------|
| | Mains and motor | | Brake | | PE | | |
| | Range | Tightening torque Nm/ft lbf | Range | Tightening torque Nm/ft lbf | Range | Tightening torque Nm/ft lbf | |
| JNVX48-0061 | AWG 12-AWG 4 | 1.6/1.2 | AWG 12-AWG 4 | 1.6/1.2 | AWG 12-AWG 4 | 1.6/1.2 | Copper (Cu) 75 °C |
| JNVX48-0074 | AWG 10-AWG 0 | 2.8/3.0 | AWG 10-AWG 0 | 2.8/3.0 | AWG 10-AWG 0 | 2.8/3.0 | |
| JNVX48-0090 | AWG 4 - AWG 3/0 | 14 / 10.5 | AWG 4 - AWG 3/0 | 14 / 10.5 | AWG 4 - AWG 3/0 (AWG 4 - AWG 2/0) ¹ | 14 / 10.5 (10 / 7.5) ¹ | |
| JNVX48-0109 | | | | | AWG 1 - AWG 3/0 (AWG 4 - AWG 2/0) ¹ | 14 / 10.5 (10 / 7.5) ¹ | |
| JNVX48-0146 | AWG 1 - AWG 3/0 AWG 4/0 - 300 kcmil | 14 / 10.5 24 / 18 | AWG 1 - AWG 3/0 AWG 4/0 - 300 kcmil | 14 / 10.5 24 / 18 | AWG 1 - AWG 3/0 (AWG 4 - AWG 2/0) ¹ | 14 / 10.5 (10 / 7.5) ¹ | |
| JNVX48-0175 | | | | | AWG 3/0 - 400 kcmil (AWG 4/0 - 400 kcmil) ¹ | 24 / 18 (10 / 7.5) ¹ | |
| JNVX48-0210 | AWG 3/0 - 400 kcmil | 24 / 18 | AWG 1 - AWG 3/0 AWG 4/0 - 300 kcmil | 14 / 10.5 24 / 18 | AWG 3/0 - 400 kcmil (AWG 4/0 - 400 kcmil) ¹ | 24 / 18 (10 / 7.5) ¹ | |
| JNVX48-0228 | | | | | | | |
| JNVX48-0250 | | | | | | | |
| JNVX48-0300 | 2 x AWG 4/0 - 2 x 300 kcmil | 24 / 18 | 2 x AWG 3/0 - 2 x 400 kcmil | 24 / 18 | frame | - | |
| JNVX48-0375 | | | | | | | |
| JNVX48-0430 | 2 x AWG 3/0 - 2 x 400 kcmil | 24 / 18 | 2 x AWG 3/0 - 2 x 400 kcmil | 24 / 18 | frame | - | |
| JNVX48-0500 | | | | | | | |
| JNVX48-0600 | 3 x AWG 4/0 - 3 x 300 kcmil | 24 / 18 | 2 x AWG 3/0 - 2 x 400 kcmil | 24 / 18 | frame | - | |
| JNVX48-0650 | | | | | | | |
| JNVX48-0750 | | | | | | | |
| JNVX48-0860 | 4 x AWG 4/0 - 4 x 300 kcmil | 24 / 18 | 3 x AWG 3/0 - 3 x 400 kcmil | 24 / 18 | frame | - | |
| JNVX48-1000 | | | | | | | |
| JNVX48-1200 | 6 x AWG 4/0 - 6 x 300 kcmil | 24 / 18 | 6 x AWG 3/0 - 6 x 400 kcmil | 24 / 18 | frame | - | |
| JNVX48-1500 | | | | | | | |

1. Values are valid when brake chopper electronics are built in.

14.7 Control signals

Table 51

| Terminal X1 | Name: | Function (Default): | Signal: | Type: |
|--------------------|----------|--|--|-----------------|
| 1 | +10 V | +10 VDC Supply voltage | +10 VDC, max 10 mA | output |
| 2 | AnIn1 | Process reference | 0 -10 VDC or 0/4-20 mA bipolar: -10 - +10 VDC or -20 - +20 mA | analogue input |
| 3 | AnIn2 | Off | 0 -10 VDC or 0/4-20 mA bipolar: -10 - +10 VDC or -20 - +20 mA | analogue input |
| 4 | AnIn3 | Off | 0 -10 VDC or 0/4-20 mA bipolar: -10 - +10 VDC or -20 - +20 mA | analogue input |
| 5 | AnIn4 | Off | 0 -10 VDC or 0/4-20 mA bipolar: -10 - +10 VDC or -20 - +20 mA | analogue input |
| 6 | -10 V | -10VDC Supply voltage | -10 VDC, max 10 mA | output |
| 7 | Common | Signal ground | 0V | output |
| 8 | DigIn 1 | RunL | 0-8/24 VDC | digital input |
| 9 | DigIn 2 | RunR | 0-8/24 VDC | digital input |
| 10 | DigIn 3 | Off | 0-8/24 VDC | digital input |
| 11 | +24 V | +24VDC Supply voltage | +24 VDC, 100 mA | output |
| 12 | Common | Signal ground | 0 V | output |
| 13 | AnOut 1 | Min speed to max speed | 0 ±10 VDC or 0/4- +20 mA | analogue output |
| 14 | AnOut 2 | 0 to max torque | 0 ±10 VDC or 0/4- +20 mA | analogue output |
| 15 | Common | Signal ground | 0 V | output |
| 16 | DigIn 4 | Off | 0-8/24 VDC | digital input |
| 17 | DigIn 5 | Off | 0-8/24 VDC | digital input |
| 18 | DigIn 6 | Off | 0-8/24 VDC | digital input |
| 19 | DigIn 7 | Off | 0-8/24 VDC | digital input |
| 20 | DigOut 1 | Ready | 24 VDC, 100 mA | digital output |
| 21 | DigOut 2 | Brake | 24 VDC, 100 mA | digital output |
| 22 | DigIn 8 | RESET | 0-8/24 VDC | digital input |
| Terminal X2 | | | | |
| 31 | N/C 1 | Relay 1 output Trip, active when the AC drive is in a TRIP condition N/C is opened when the relay is active (valid for all relays) N/O is closed when the relay is active (valid for all relays) | potential free change over 0.1 - 2 A/U _{max} 250 VAC or 42 VDC | relay output |
| 32 | COM 1 | | | |
| 33 | N/O 1 | | | |
| 41 | N/C 2 | Relay 2 Output Run, active when the AC drive is started | potential free change over 0.1 - 2 A/U _{max} 250 VAC or 42 VDC | relay output |
| 42 | COM 2 | | | |
| 43 | N/O 2 | | | |
| Terminal X3 | | | | |
| 51 | COM 3 | Relay 3 Output Off | potential free change over 0.1 - 2 A/U _{max} 250 VAC or 42 VDC | relay output |
| 52 | N/O 3 | | | |

15. Menu List

| | | DEFAULT | CUSTOM |
|------|---------------------------|------------------|--------|
| 100 | Preferred View | | |
| 110 | 1st Line | Process Val | |
| 120 | 2nd Line | Torque | |
| 200 | Main Setup | | |
| 210 | Operation | | |
| 211 | Language | English | |
| 212 | Select Motor | M1 | |
| 213 | Drive Mode | Speed | |
| 214 | Ref Control | Remote | |
| 215 | Run/Stp Ctrl | Remote | |
| 216 | Reset Ctrl | Remote | |
| 217 | Local/Rem | | |
| 2171 | LocRefCtrl | Standard | |
| 2172 | LocRunCtrl | Standard | |
| 218 | Lock Code? | 0 | |
| 219 | Rotation | R+L | |
| 21A | Level/Edge | Level | |
| 21B | Supply Volts | Not Defined | |
| 220 | Motor Data | | |
| 221 | Motor Volts | U_{NOM} V | |
| 222 | Motor Freq | 50Hz | |
| 223 | Motor Power | (P_{NOM}) W | |
| 224 | Motor Curr | (I_{MOT}) A | |
| 225 | Motor Speed | (n_{MOT}) rpm | |
| 226 | Motor Poles | 4 | |
| 227 | Motor Cosφ | $\cos\phi_{NOM}$ | |
| 228 | Motor Vent | Self | |
| 229 | Motor ID-Run | Off | |
| 22B | Encoder | Off | |
| 22C | Enc Pulses | 1024 | |
| 22D | Enc Speed | Orpm | |
| 230 | Mot Protect | | |
| 231 | Mot I ² t Type | Trip | |
| 232 | Mot I ² t Curr | 100% | |
| 233 | Mot I ² t Time | 60s | |
| 234 | Thermal Prot | Off | |
| 235 | Motor Class | F 140°C | |
| 236 | PT100 Inputs | PT100 1+2+3 | |
| 237 | Motor PTC | Off | |
| 240 | Set Handling | | |
| 241 | Select Set | A | |
| 242 | Copy Set | A>B | |
| 243 | Default>Set | A | |
| 244 | Copy to CP | No Copy | |
| 245 | Load from CP | No Copy | |
| 250 | Autoreset | | |
| 251 | No of Trips | 0 | |
| 252 | Overtemp | Off | |
| 253 | Overvolt D | Off | |
| 254 | Overvolt G | Off | |
| 255 | Overvolt | Off | |

| | | DEFAULT | CUSTOM |
|------|---------------------------|--------------|--------|
| 256 | Motor Lost | Off | |
| 257 | Locked Rotor | Off | |
| 258 | Power Fault | Off | |
| 259 | Undervoltage | Off | |
| 25A | Motor I ² t | Off | |
| 25B | Motor I ² t TT | Trip | |
| 25C | PT100 | Off | |
| 25D | PT100 TT | Trip | |
| 25E | PTC | Off | |
| 25F | PTC TT | Trip | |
| 25G | Ext Trip | Off | |
| 25H | Ext Trip TT | Trip | |
| 25I | Com Error | Off | |
| 25J | Com Error TT | Trip | |
| 25K | Min Alarm | Off | |
| 25L | Min Alarm TT | Trip | |
| 25M | Max Alarm | Off | |
| 25N | Max Alarm TT | Trip | |
| 25O | Over curr F | Off | |
| 25Q | Over speed | Off | |
| 25R | Ext Mot Temp | Off | |
| 25S | Ext Mot TT | Trip | |
| 25T | LC Level | Off | |
| 25U | LC Level TT | Trip | |
| 25V | Brk Fault | Off | |
| 260 | Serial Com | | |
| 261 | Com Type | RS232/485 | |
| 262 | RS232/485 | | |
| 2621 | Baudrate | 9600 | |
| 2622 | Address | 1 | |
| 263 | Fieldbus | | |
| 2631 | Address | 62 | |
| 2632 | PrData Mode | Basic | |
| 2633 | Read/Write | RW | |
| 2634 | AddPrValue | 0 | |
| 264 | Comm Fault | | |
| 2641 | ComFlt Mode | Off | |
| 2642 | ComFlt Time | 0.5 s | |
| 265 | Ethernet | | |
| 2651 | IP Address | 0.0.0.0 | |
| 2652 | MAC Address | 000000000000 | |
| 2653 | Subnet Mask | 0.0.0.0 | |
| 2654 | Gateway | 0.0.0.0 | |
| 2655 | DHCP | Off | |
| 266 | FB Signal | | |
| 2661 | FB Signal 1 | 0 | |
| 2662 | FB Signal 2 | 0 | |
| 2663 | FB Signal 3 | 0 | |
| 2664 | FB Signal 4 | 0 | |
| 2665 | FB Signal 5 | 0 | |
| 2666 | FB Signal 6 | 0 | |
| 2667 | FB Signal 7 | 0 | |
| 2668 | FB Signal 8 | 0 | |
| 2669 | FB Signal 9 | 0 | |

| | | DEFAULT | CUSTOM |
|------|----------------|------------|--------|
| 266A | FB Signal 10 | 0 | |
| 266B | FB Signal 11 | 0 | |
| 266C | FB Signal 12 | 0 | |
| 266D | FB Signal 13 | 0 | |
| 266E | FB Signal 14 | 0 | |
| 266F | FB Signal 15 | 0 | |
| 266G | FB Signal 16 | 0 | |
| 269 | FB Status | | |
| 300 | Process | | |
| 310 | Set/View ref | Orpm | |
| 320 | Proc Setting | | |
| 321 | Proc Source | Speed | |
| 322 | Proc Unit | rpm | |
| 323 | User Unit | 0 | |
| 324 | Process Min | 0 | |
| 325 | Process Max | 0 | |
| 326 | Ratio | Linear | |
| 327 | F(Val) PrMin | Min | |
| 328 | F(Val) PrMax | Max | |
| 330 | Start/Stop | | |
| 331 | Acc Time | 10.00s | |
| 332 | Dec Time | 10.00s | |
| 333 | Acc MotPot | 16.00s | |
| 334 | Dec MotPot | 16.00s | |
| 335 | Acc>Min Spd | 10.00s | |
| 336 | Dec<Min Spd | 10.00s | |
| 337 | Acc Rmp | Linear | |
| 338 | Dec Rmp | Linear | |
| 339 | Start Mode | Normal DC | |
| 33A | Spinstart | Off | |
| 33B | Stop Mode | Decel | |
| 33C | Brk Release | 0.00s | |
| 33D | Release Spd | Orpm | |
| 33E | Brk Engage | 0.00s | |
| 33F | Brk Wait | 0.00s | |
| 33G | Vector Brake | Off | |
| 33H | Brk Fault | 1.00s | |
| 33I | Release Torque | 0% | |
| 340 | Speed | | |
| 341 | Min Speed | Orpm | |
| 342 | Stp<MinSpd | Off | |
| 343 | Max Speed | Sync Speed | |
| 344 | SkipSpd 1 Lo | Orpm | |
| 345 | SkipSpd 1 Hi | Orpm | |
| 346 | SkipSpd 2 Lo | Orpm | |
| 347 | SkipSpd 2 Hi | Orpm | |
| 348 | Jog Speed | 50rpm | |
| 350 | Torques | | |
| 351 | Max Torque | 120% | |
| 352 | IxR Comp | Off | |
| 353 | IxR CompUsr | 0% | |
| 354 | Flux optim | Off | |
| 355 | Max Power | Off | |
| 360 | Preset Ref | | |

| | | DEFAULT | CUSTOM |
|------|---------------|--------------|--------|
| 361 | Motor Pot | Non Volatile | |
| 362 | Preset Ref 1 | 0 rpm | |
| 363 | Preset Ref 2 | 250 rpm | |
| 364 | Preset Ref 3 | 500 rpm | |
| 365 | Preset Ref 4 | 750 rpm | |
| 366 | Preset Ref 5 | 1000 rpm | |
| 367 | Preset Ref 6 | 1250 rpm | |
| 368 | Preset Ref 7 | 1500 rpm | |
| 369 | Keyb Ref | Mot Pot | |
| 370 | Spd Ctrl PI | | |
| 371 | Spd PI Auto | Off | |
| 372 | Spd P Gain | | |
| 373 | Spd I Time | | |
| 380 | ProcCtrlPID | | |
| 381 | PID Control | Off | |
| 383 | PID P Gain | 1.0 | |
| 384 | PID I Time | 1.00s | |
| 385 | PID D Time | 0.00s | |
| 386 | PID<MinSpd | Off | |
| 387 | PID Act Marg | 0 | |
| 388 | PID Stdy Tst | Off | |
| 389 | PID Stdy Mar | 0 | |
| 390 | Pump/Fan Ctrl | | |
| 391 | Pump enable | Off | |
| 392 | No of Drives | 2 | |
| 393 | Select Drive | Sequence | |
| 394 | Change Cond | Both | |
| 395 | Change Timer | 50h | |
| 396 | Drives on Ch | 0 | |
| 397 | Upper Band | 10% | |
| 398 | Lower Band | 10% | |
| 399 | Start Delay | 0s | |
| 39A | Stop Delay | 0s | |
| 39B | Upp Band Lim | 0% | |
| 39C | Low Band Lim | 0% | |
| 39D | Settle Start | 0s | |
| 39E | TransS Start | 60% | |
| 39F | Settle Stop | 0s | |
| 39G | TransS Stop | 60% | |
| 39H | Run Time 1 | 00:00:00 | |
| 39H1 | Rst Run Tm1 | No | |
| 39I | Run Time 2 | 00:00:00 | |
| 39I1 | Rst Run Tm2 | No | |
| 39J | Run Time 3 | 00:00:00 | |
| 39J1 | Rst Run Tm3 | No | |
| 39K | Run Time 4 | 00:00:00 | |
| 39K1 | Rst Run Tm4 | No | |
| 39L | Run Time05 | 00:00:00 | |
| 39L1 | Rst Run Tm5 | No | |
| 39M | Run Time 6 | 00:00:00 | |
| 39M1 | Rst Run Tm6 | No | |
| 39N | Pump 123456 | | |
| 39P | No of Backup | 0 | |
| 3A0 | Crane Option | | |

| | | | DEFAULT | CUSTOM |
|-----|--------------|---------------|-------------|--------|
| | 3A1 | Crane enable | Off | |
| | 3A2 | Control | 4-Speed | |
| | 3A3 | Crane Relay 1 | No trip | |
| | 3A4 | Crane Relay 2 | Brake | |
| | 3A5 | PreLimSwSpd | | |
| | 3A6 | CrawlSpd H/R | | |
| | 3A7 | CrawlSpd L/L | | |
| | 3A8 | Speed 2 | | |
| | 3A9 | Speed 3 | | |
| | 3AA | Speed 4 | | |
| | 3AB | Dev Bandwidht | | |
| | 3AC | Dev Time | ms | |
| | 3AD | LAFS Load | Off | |
| | 3AE | Crane Inputs | | |
| | 3AF | CraneOutputs | | |
| 400 | Monitor/Prot | | | |
| | 410 | Load Monitor | | |
| | 411 | Alarm Select | Off | |
| | 412 | Alarm trip | Off | |
| | 413 | Ramp Alarm | Off | |
| | 414 | Start Delay | 2s | |
| | 415 | Load Type | Basic | |
| | 416 | Max Alarm | | |
| | 4161 | MaxAlarmMar | 15% | |
| | 4162 | MaxAlarmDel | 0.1s | |
| | 417 | Max Pre alarm | | |
| | 4171 | MaxPreAlMar | 10% | |
| | 4172 | MaxPreAlDel | 0.1s | |
| | 418 | Min Pre Alarm | | |
| | 4181 | MinPreAlMar | 10% | |
| | 4182 | MinPreAlDel | 0.1s | |
| | 419 | Min Alarm | | |
| | 4191 | MinAlarmMar | 15% | |
| | 4192 | MinAlarmDel | 0.1s | |
| | 41A | Autoset Alrm | No | |
| | 41B | Normal Load | 100% | |
| | 41C | Load Curve | | |
| | 41C1 | Load Curve 1 | 100% | |
| | 41C2 | Load Curve 2 | 100% | |
| | 41C3 | Load Curve 3 | 100% | |
| | 41C4 | Load Curve 4 | 100% | |
| | 41C5 | Load Curve 5 | 100% | |
| | 41C6 | Load Curve 6 | 100% | |
| | 41C7 | Load Curve 7 | 100% | |
| | 41C8 | Load Curve 8 | 100% | |
| | 41C9 | Load Curve 9 | 100% | |
| | 420 | Process Prot | | |
| | 421 | Low Volt OR | On | |
| | 422 | Rotor Locked | Off | |
| | 423 | Motor lost | Off | |
| | 424 | Overvolt Ctrl | On | |
| 500 | I/Os | | | |
| | 510 | An Inputs | | |
| | 511 | AnIn1 Fc | Process Ref | |

| | | | DEFAULT | CUSTOM |
|------|--------------|--------------------|---------|--------|
| 512 | AnIn1 Setup | 4-20mA | | |
| 513 | AnIn1 Advn | | | |
| 5131 | AnIn1 Min | 4mA | | |
| 5132 | AnIn1 Max | 10.00V/ 20.00mA | | |
| 5133 | AnIn1 Bipol | 10.00V/ 20.00mA | | |
| 5134 | AnIn1 FcMin | Min | | |
| 5135 | AnIn1 ValMin | 0 | | |
| 5136 | AnIn1 FcMax | Max | | |
| 5137 | AnIn1 ValMax | 0 | | |
| 5138 | AnIn1 Oper | Add+ | | |
| 5139 | AnIn1 Filt | 0.1s | | |
| 513A | AnIn1 Enabl | On | | |
| 514 | AnIn2 Fc | Off | | |
| 515 | AnIn2 Setup | 4-20mA | | |
| 516 | AnIn2 Advn | | | |
| 5161 | AnIn2 Min | 4mA | | |
| 5162 | AnIn2 Max | 20.00mA | | |
| 5163 | AnIn2 Bipol | 20.00mA | | |
| 5164 | AnIn2 FcMin | Min | | |
| 5165 | AnIn2 ValMin | 0 | | |
| 5166 | AnIn2 FcMax | Max | | |
| 5167 | AnIn2 ValMax | 0 | | |
| 5168 | AnIn2 Oper | Add+ | | |
| 5169 | AnIn2 Filt | 0.1s | | |
| 516A | AnIn2 Enabl | On | | |
| 517 | AnIn3 Fc | Off | | |
| 518 | AnIn3 Setup | 4-20mA | | |
| 519 | AnIn3 Advn | | | |
| 5191 | AnIn3 Min | 4mA | | |
| 5192 | AnIn3 Max | 20.00mA | | |
| 5193 | AnIn3 Bipol | 20.00mA | | |
| 5194 | AnIn3 FcMin | Min | | |
| 5195 | AnIn3 ValMin | 0 | | |
| 5196 | AnIn3 FcMax | Max | | |
| 5197 | AnIn3 ValMax | 0 | | |
| 5198 | AnIn3 Oper | Add+ | | |
| 5199 | AnIn3 Filt | 0.1s | | |
| 519A | AnIn3 Enabl | On | | |
| 51A | AnIn4 Fc | Off | | |
| 51B | AnIn4 Setup | 4-20mA | | |
| 51C | AnIn4 Advn | | | |
| 51C1 | AnIn4 Min | 4mA | | |
| 51C2 | AnIn4 Max | 20.00mA | | |
| 51C3 | AnIn4 Bipol | 20.00mA | | |
| 51C4 | AnIn4 FcMin | Min | | |
| 51C5 | AnIn4 ValMin | 0 | | |
| 51C6 | AnIn4 FcMax | Max | | |
| 51C7 | AnIn4 ValMax | 0 | | |
| 51C8 | AnIn4 Oper | Add+ | | |
| 51C9 | AnIn4 Filt | 0.1s | | |
| 51CA | AnIn4 Enabl | On | | |
| 520 | Dig Inputs | | | |
| 521 | DigIn 1 | RunL | | |

| | | DEFAULT | CUSTOM |
|------|------------------|----------------|--------|
| 522 | DigIn 2 | RunR | |
| 523 | DigIn 3 | Off | |
| 524 | DigIn 4 | Off | |
| 525 | DigIn 5 | Off | |
| 526 | DigIn 6 | Off | |
| 527 | DigIn 7 | Off | |
| 528 | DigIn 8 | Reset | |
| 529 | B(oard)1 DigIn 1 | Off | |
| 52A | B(oard)1 DigIn 2 | Off | |
| 52B | B(oard)1 DigIn 3 | Off | |
| 52C | B(oard)2 DigIn 1 | Off | |
| 52D | B(oard)2 DigIn 2 | Off | |
| 52E | B(oard)2 DigIn 3 | Off | |
| 52F | B(oard)3 DigIn 1 | Off | |
| 52G | B(oard)3 DigIn 2 | Off | |
| 52H | B(oard)3 DigIn 3 | Off | |
| 530 | An Outputs | | |
| 531 | AnOut1 Fc | Speed | |
| 532 | AnOut1 Setup | 4-20mA | |
| 533 | AnOut1 Adv | | |
| 5331 | AnOut 1 Min | 4mA | |
| 5332 | AnOut 1 Max | 20.0mA | |
| 5333 | AnOut1Bipol | -10.00-10.00 V | |
| 5334 | AnOut1 FcMin | Min | |
| 5335 | AnOut1 VIMin | 0 | |
| 5336 | AnOut1 FcMax | Max | |
| 5337 | AnOut1 VIMax | 0 | |
| 534 | AnOut2 FC | Torque | |
| 535 | AnOut2 Setup | 4-20mA | |
| 536 | AnOut2 Advan | | |
| 5361 | AnOut 2 Min | 4mA | |
| 5362 | AnOut 2 Max | 20.0mA | |
| 5363 | AnOut2Bipol | -10.00-10.00 V | |
| 5364 | AnOut2 FcMin | Min | |
| 5365 | AnOut2 VIMin | 0 | |
| 5366 | AnOut2 FcMax | Max | |
| 5367 | AnOut2 VIMax | 0 | |
| 540 | Dig Outputs | | |
| 541 | DigOut 1 | Ready | |
| 542 | DigOut 2 | Brake | |
| 550 | Relays | | |
| 551 | Relay 1 | Trip | |
| 552 | Relay 2 | Run | |
| 553 | Relay 3 | Off | |
| 554 | B(oard)1 Relay 1 | Off | |
| 555 | B(oard)1 Relay 2 | Off | |
| 556 | B(oard)1 Relay 3 | Off | |
| 557 | B(oard)2 Relay 1 | Off | |
| 558 | B(oard)2 Relay 2 | Off | |
| 559 | B(oard)2 Relay 3 | Off | |
| 55A | B(oard)3 Relay 1 | Off | |
| 55B | B(oard)3 Relay 2 | Off | |
| 55C | B(oard)3 Relay 3 | Off | |
| 55D | Relay Adv | | |

| | | DEFAULT | CUSTOM |
|------|----------------|-------------|--------|
| 55D1 | Relay 1 Mode | N.O | |
| 55D2 | Relay 2 Mode | N.O | |
| 55D3 | Relay 3 Mode | N.O | |
| 55D4 | B1R1 Mode | N.O | |
| 55D5 | B1R2 Mode | N.O | |
| 55D6 | B1R3 Mode | N.O | |
| 55D7 | B2R1 Mode | N.O | |
| 55D8 | B2R2 Mode | N.O | |
| 55D9 | B2R3 Mode | N.O | |
| 55DA | B3R1 Mode | N.O | |
| 55DB | B3R2 Mode | N.O | |
| 55DC | B3R3 Mode | N.O | |
| 560 | Virtual I/Os | | |
| 561 | VIO 1 Dest | Off | |
| 562 | VIO 1 Source | Off | |
| 563 | VIO 2 Dest | Off | |
| 564 | VIO 2 Source | Off | |
| 565 | VIO 3 Dest | Off | |
| 566 | VIO 3 Source | Off | |
| 567 | VIO 4 Dest | Off | |
| 568 | VIO 4 Source | Off | |
| 569 | VIO 5 Dest | Off | |
| 56A | VIO 5 Source | Off | |
| 56B | VIO 6 Dest | Off | |
| 56C | VIO 6 Source | Off | |
| 56D | VIO 7 Dest | Off | |
| 56E | VIO 7 Source | Off | |
| 56F | VIO 8 Dest | Off | |
| 56G | VIO 8 Source | Off | |
| 600 | Logical&Timers | | |
| 610 | Comparators | | |
| 611 | CA1 Setup | | |
| 6111 | CA1 Value | Speed | |
| 6112 | CA1 Level HI | 300rpm | |
| 6113 | CA1 Level LO | 200rpm | |
| 6114 | CA1 Type | Hysteresis | |
| 6115 | CA1 Bipolar | Unipolar | |
| 612 | CA2 Setup | | |
| 6121 | CA2 Value | Torque | |
| 6122 | CA2 Level HI | 20% | |
| 6123 | CA2 Level LO | 10% | |
| 6124 | CA2 Type | Hysteresis | |
| 6125 | CA2 Bipolar | Unipolar | |
| 613 | CA3 Setup | | |
| 6131 | CA3 Value | Process Val | |
| 6132 | CA3 Level HI | 300rpm | |
| 6133 | CA3 Level LO | 200rpm | |
| 6134 | CA3 Type | Hysteresis | |
| 6135 | CA3 Bipolar | Unipolar | |
| 614 | CA4 Setup | | |
| 6141 | CA4 Value | Process Err | |
| 6142 | CA4 Level HI | 100 rpm | |
| 6143 | CA4 Level LO | - 100 rpm | |
| 6144 | CA4 Type | Window | |

| | | DEFAULT | CUSTOM |
|------|------------------|---------|--------|
| 6145 | CA4 Bipolar | Bipolar | |
| 615 | CD Setup | | |
| 6151 | CD1 | Run | |
| 6152 | CD2 | DigIn 1 | |
| 6153 | CD3 | Trip | |
| 6154 | CD4 | Ready | |
| 620 | Logic Output Y | | |
| 621 | Y Comp 1 | CA1 | |
| 622 | Y Operator 1 | & | |
| 623 | Y Comp 2 | !A2 | |
| 624 | Y Operator 2 | & | |
| 625 | Y Comp 3 | CD1 | |
| 630 | Logic Z | | |
| 631 | Z Comp 1 | CA1 | |
| 632 | Z Operator 1 | & | |
| 633 | Z Comp2 | !A2 | |
| 634 | Z Operator 2 | & | |
| 635 | Z Comp 3 | CD1 | |
| 640 | Timer1 | | |
| 641 | Timer1 Trig | Off | |
| 642 | Timer1 Mode | Off | |
| 643 | Timer1 Delay | 0:00:00 | |
| 644 | Timer 1 T1 | 0:00:00 | |
| 645 | Timer1 T2 | 0:00:00 | |
| 649 | Timer1 Value | 0:00:00 | |
| 650 | Timer2 | | |
| 651 | Timer2 Trig | Off | |
| 652 | Timer2 Mode | Off | |
| 653 | Timer2 Delay | 0:00:00 | |
| 654 | Timer 2 T1 | 0:00:00 | |
| 655 | Timer2 T2 | 0:00:00 | |
| 659 | Tmer2 Value | 0:00:00 | |
| 700 | Oper/Status | | |
| 710 | Operation | | |
| 711 | Process Val | | |
| 712 | Speed | | |
| 713 | Torque | | |
| 714 | Shaft Power | | |
| 715 | Electrical Power | | |
| 716 | Current | | |
| 717 | Output volt | | |
| 718 | Frequency | | |
| 719 | DC Voltage | | |
| 71A | Heatsink Tmp | | |
| 71B | PT100_1_2_3 | | |
| 720 | Status | | |
| 721 | AC drive Status | | |
| 722 | Warning | | |
| 723 | DigIn Status | | |
| 724 | DigOut Status | | |
| 725 | AnIn Status 1-2 | | |
| 726 | AnIn Status 3-4 | | |
| 727 | AnOut Status 1-2 | | |
| 728 | IO Status B1 | | |

| | | DEFAULT | CUSTOM |
|------|------------------|----------|--------|
| 729 | IO Status B2 | | |
| 72A | IO Status B3 | | |
| 730 | Stored Val | | |
| 731 | Run Time | 00:00:00 | |
| 7311 | Reset RunTm | No | |
| 732 | Mains Time | 00:00:00 | |
| 733 | Energy | kWh | |
| 7331 | Rst Energy | No | |
| 800 | View TripLog | | |
| 810 | Trip Message | | |
| 811 | Process Value | | |
| 812 | Speed | | |
| 813 | Torque | | |
| 814 | Shaft Power | | |
| 815 | Electrical Power | | |
| 816 | Current | | |
| 817 | Output voltage | | |
| 818 | Frequency | | |
| 819 | DC Link voltage | | |
| 81A | Heatsink Tmp | | |
| 81B | PT100_1, 2, 3 | | |
| 81C | AC drive Status | | |
| 81D | DigIn status | | |
| 81E | DigOut status | | |
| 81F | AnIn status 1 2 | | |
| 81G | AnIn status 3 4 | | |
| 81H | AnOut status 1 2 | | |
| 81I | IO Status B1 | | |
| 81J | IO Status B2 | | |
| 81K | IO Status B3 | | |
| 81L | Run Time | | |
| 81M | Mains Time | | |
| 81N | Energy | | |
| 820 | Trip Message | | |
| 821 | Process Value | | |
| 822 | Speed | | |
| 823 | Torque | | |
| 824 | Shaft Power | | |
| 825 | Electrical Power | | |
| 826 | Current | | |
| 827 | Output voltage | | |
| 828 | Frequency | | |
| 829 | DC Link voltage | | |
| 82A | Heatsink Tmp | | |
| 82B | PT100_1, 2, 3 | | |
| 82C | AC drive Status | | |
| 82D | DigIn status | | |
| 82E | DigOut status | | |
| 82F | AnIn status 1 2 | | |
| 82G | AnIn status 3 4 | | |
| 82H | AnOut status 1 2 | | |
| 82I | IO Status B1 | | |
| 82J | IO Status B2 | | |
| 82K | IO Status B3 | | |

| | | DEFAULT | CUSTOM |
|-----|-----|----------------------|--------|
| | 82L | Run Time | |
| | 82M | Mains Time | |
| | 82N | Energy | |
| 830 | | | |
| | 831 | Process Value | |
| | 832 | Speed | |
| | 833 | Torque | |
| | 834 | Shaft Power | |
| | 835 | Electrical Power | |
| | 836 | Current | |
| | 837 | Output voltage | |
| | 838 | Frequency | |
| | 839 | DC Link voltage | |
| | 83A | Heatsink Temperature | |
| | 83B | PT100_1, 2, 3 | |
| | 83C | AC drive Status | |
| | 83D | DigIn status | |
| | 83E | DigOut status | |
| | 83F | AnIn status 1 2 | |
| | 83G | AnIn status 3 4 | |
| | 83H | AnOut status 1 2 | |
| | 83I | IO Status B1 | |
| | 83J | IO Status B2 | |
| | 83K | IO Status B3 | |
| | 83L | Run Time | |
| | 83M | Mains Time | |
| | 83N | Energy | |
| 840 | | | |
| | 841 | Process Value | |
| | 842 | Speed | |
| | 843 | Torque | |
| | 844 | Shaft Power | |
| | 845 | Electrical Power | |
| | 846 | Current | |
| | 847 | Output voltage | |
| | 848 | Frequency | |
| | 849 | DC Link voltage | |
| | 84A | Heatsink Tmp | |
| | 84B | PT100_1, 2, 3 | |
| | 84C | AC drive Status | |
| | 84D | DigIn status | |
| | 84E | DigOut status | |
| | 84F | AnIn status 1 2 | |
| | 84G | AnIn status 3 4 | |
| | 84H | AnOut status 1 2 | |
| | 84I | IO Status B1 | |
| | 84J | IO Status B2 | |
| | 84K | IO Status B3 | |
| | 84L | Run Time | |
| | 84M | Mains Time | |
| | 84N | Energy | |
| 850 | | | |
| | 851 | Process Value | |
| | 852 | Speed | |

| | | DEFAULT | CUSTOM |
|-----|-----|------------------|--------|
| | 853 | Torque | |
| | 854 | Shaft Power | |
| | 855 | Electrical Power | |
| | 856 | Current | |
| | 857 | Output voltage | |
| | 858 | Frequency | |
| | 859 | DC Link voltage | |
| | 85A | Heatsink Tmp | |
| | 85B | PT100_1, 2, 3 | |
| | 85C | AC drive Status | |
| | 85D | DigIn status | |
| | 85E | DigOut status | |
| | 85F | AnIn 1 2 | |
| | 85G | AnIn 3 4 | |
| | 85H | AnIOut 1 2 | |
| | 85I | IO Status B1 | |
| | 85J | IO Status B2 | |
| | 85K | IO Status B3 | |
| | 85L | Run Time | |
| | 85M | Mains Time | |
| | 85N | Energy | |
| 860 | | | |
| | 861 | Process Value | |
| | 862 | Speed | |
| | 863 | Torque | |
| | 864 | Shaft Power | |
| | 865 | Electrical Power | |
| | 866 | Current | |
| | 867 | Output voltage | |
| | 868 | Frequency | |
| | 869 | DC Link voltage | |
| | 86A | Heatsink Tmp | |
| | 86B | PT100_1, 2, 3 | |
| | 86C | AC drive Status | |
| | 86D | DigIn status | |
| | 86E | DigOut status | |
| | 86F | AnIn 1 2 | |
| | 86G | AnIn 3 4 | |
| | 86H | AnOut 1 2 | |
| | 86I | IO Status B1 | |
| | 86J | IO Status B 2 | |
| | 86K | IO Status B3 | |
| | 86L | Run Time | |
| | 86M | Mains Time | |
| | 86N | Energy | |
| 870 | | | |
| | 871 | Process Value | |
| | 872 | Speed | |
| | 873 | Torque | |
| | 874 | Shaft Power | |
| | 875 | Electrical Power | |
| | 876 | Current | |
| | 877 | Output voltage | |
| | 878 | Frequency | |

| | | DEFAULT | CUSTOM |
|-----|------------------|---------|--------|
| 879 | DC Link voltage | | |
| 87A | Heatsink Tmpe | | |
| 87B | PT100_1, 2, 3 | | |
| 87C | AC drive Status | | |
| 87D | DigIn status | | |
| 87E | DigOut status | | |
| 87F | AnIn status 1 2 | | |
| 87G | AnIn status 3 4 | | |
| 87H | AnOut status 1 2 | | |
| 87I | IO Status B1 | | |
| 87J | IO Status B2 | | |
| 87K | IO Status B3 | | |
| 87L | Run Time | | |
| 87M | Mains Time | | |
| 87N | Energy | | |
| 880 | | | |
| 881 | Process Value | | |
| 882 | Speed | | |
| 818 | Torque | | |
| 884 | Shaft Power | | |
| 885 | Electrical Power | | |
| 886 | Current | | |
| 887 | Output voltage | | |
| 888 | Frequency | | |
| 889 | DC Link voltage | | |
| 88A | Heatsink Tmp | | |
| 88B | PT100_1, 2, 3 | | |
| 88C | AC drive Status | | |
| 88D | DigIn status | | |
| 88E | DigOut status | | |
| 88F | AnIn status 1 2 | | |
| 88G | AnIn status 3 4 | | |
| 88H | AnOut status 1 2 | | |
| 88I | IO Status B1 | | |
| 88J | IO Status B2 | | |
| 88K | IO Status B3 | | |
| 88L | Run Time | | |
| 88M | Mains Time | | |
| 88N | Energy | | |
| 890 | | | |
| 891 | Process Value | | |
| 892 | Speed | | |
| 893 | Torque | | |
| 894 | Shaft Power | | |
| 895 | Electrical Power | | |
| 896 | Current | | |
| 897 | Output voltage | | |
| 898 | Frequency | | |
| 899 | DC Link voltage | | |
| 89A | Heatsink Tmp | | |
| 89B | PT100_1, 2, 3 | | |
| 89C | AC drive Status | | |
| 89D | DigIn status | | |
| 89E | DigOut status | | |

| | | DEFAULT | CUSTOM |
|-----|------------------|---------|--------|
| 89F | AnIn status 1 2 | | |
| 89G | AnIn status 3 4 | | |
| 89H | AnOut status 1 2 | | |
| 89I | IO Status B1 | | |
| 89J | IO Status B2 | | |
| 89K | IO Status B3 | | |
| 89L | Run Time | | |
| 89M | Mains Time | | |
| 89N | Energy | | |
| 8A0 | Reset Trip | No | |
| 900 | System Data | | |
| 920 | AC drive Data | | |
| 921 | AC drive Type | | |
| 922 | Software | | |
| 923 | Unit name | 0 | |

Index

Symbols

- +10VDC Supply voltage 192
- +24VDC Supply voltage 192

Numerics

- 10VDC Supply voltage 192
- Menu
 - 78, 80, 81, 96, 98, 110, 111, 112, 115, 118
- 4-20mA 121
- Menu
 - 119, 121, 122

A

- Abbreviations 8
- Acceleration 86, 88
 - Acceleration ramp 88
 - Acceleration time 86
 - Ramp type 88
- Alarm trip 113
- Alternating MASTER 104
- Ambient temperature and derating 184
- Analogue comparators 136
- Analogue input 119
 - AnIn1 119
 - AnIn2 124, 125
 - Offset 120, 128
- Analogue Output 128, 131, 192
 - AnOut 1 128, 131
 - Output configuration 128, 131
- AND operator 147
- AnIn2 124
- AnIn3 125
- AnIn4 125
- Autoreset 2, 38, 71, 166
- Autotune 99

B

- Baudrate 49, 78, 79
- Brake chopper 172
- Brake function 90, 91
 - Bake release time 90
 - Brake 91
 - Brake Engage Time 91
 - Brake wait time 92
 - Release speed 91
 - Vector Brake 92
- Brake functions
 - Frequency 119
- Brake resistors 172

C

- Cable cross-section 187
- Cable specifications 20
- CE-marking 7
- Change Condition 105

- Change Timer 105
- Clockwise rotary field 126
- Com Type 78
- Comparators 136
- Connecting control signals 26
- Connections
 - Brake chopper connections 16
 - Control signal connections 26
 - Mains supply 16, 29
 - Motor earth 16, 29
 - Motor output 16, 29
 - Safety earth 16, 29
- Control panel 45
- Control Panel memory 40
 - Copy all settings to Control Panel . 70
 - Frequency 119
- Control signal connections 26
- Control signals 24, 27
 - Edge-controlled 39, 60
 - Level-controlled 39, 60
- Counter-clockwise rotary field 126
- Crane Option 110
- critical 154
- Current 24
- Current control (0-20mA) 28

D

- DC-link residual voltage 2
- Deceleration 87
 - Deceleration time 87
 - Ramp type 89
- Declaration of Conformity 7
- Default 70
- Definitions 8
- Derating 184
- Digital comparators 136
- Digital inputs
 - Board Relay 134
 - DigIn 1 126
 - DigIn 2 127
 - DigIn 3 127
- Dismantling and scrapping 7
- Display 45
- Double-ended connection 27
- Drive mode 57
 - Frequency 119
- Drives on Change 105

E

- ECP 171
- Edge control 39, 60, 61
- Electrical specification 183
- EMC 16
 - Current control (0-20mA) 28
 - Double-ended connection 27
 - RFI mains filter 16

- Single-ended connection 27
 - Twisted cables 28
- Emergency stop 43
- EN60204-1 7
- EN61800-3 7
- EN61800-5-1 7
- Enable 37, 47, 126
- EXOR operator 147
- Expression 147
- External Control Panel 171

F

- Factory settings 70
- Fans 104
- Fieldbus 79, 174
- Fixed MASTER 104
- Flux optimization 97
- Frequency
 - Frequency priority 36
 - Jog Frequency 95
 - Maximum Frequency 93, 94
 - Minimum Frequency 93
 - Preset Frequency 98
 - Skip Frequency 94, 95
- Frequency priority 36
- Fuses, cable cross-sections and glands .. 187

G

- General electrical specifications 183
- Global parameters 68

I

- I/O Board 173
- I2t protection
 - Motor I2t Current 66, 67
 - Motor I2t Type 65
- ID run 40, 64
- Identification Run 40, 64
- IEC269 187
- Internal speed control 99
- Internal speed controller 99
 - Speed I Time 100
 - Speed P Gain 100
- Interrupt 80, 81
- IT Mains supply 2
- IxR Compensation 96

J

- Jog Frequency 95

K

- Keyboard reference 99
- Keys 47
 - Key 48
 - + Key 48

| | | | | | |
|-----------------------------|------------|--------------|--------|--------------|-----|
| Control keys | 47 | (231) | 65 | (323) | 84 |
| ENTER key | 48 | (232) | 66 | (324) | 85 |
| ESCAPE key | 48 | (233) | 66 | (325) | 85 |
| Function keys | 48 | (234) | 67 | (326) | 85 |
| NEXT key | 48 | (235) | 67 | (327) | 85 |
| PREVIOUS key | 48 | (236) | 68 | (328) | 86 |
| RUN L | 47 | (237) | 68 | (331) | 86 |
| RUN R | 47 | (240) | 68 | (332) | 87 |
| STOP/RESET | 47 | (241) | 68 | (333) | 87 |
| Toggle Key | 47 | (242) | 69 | (334) | 87 |
| | | (243) | 70 | (335) | 88 |
| | | (244) | 70 | (336) | 88 |
| | | (245) | 71 | (337) | 88 |
| | | (250) | 71 | (338) | 89 |
| | | (251) | 71 | (339) | 89 |
| | | (252) | 72 | (33A) | 89 |
| | | (253) | 72 | (33B) | 90 |
| | | (254) | 72 | (33C) | 90 |
| | | (255) | 73 | (33D) | 91 |
| | | (256) | 73 | (33E) | 91 |
| | | (257) | 73 | (33F) | 92 |
| | | (258) | 73 | (33G) | 92 |
| | | (259) | 73 | (33H1) | 92 |
| | | (25A) | 74 | (341) | 93 |
| | | (25B) | 74 | (342) | 93 |
| | | (25C) | 74 | (343) | 94 |
| | | (25D) | 74 | (344) | 94 |
| | | (25E) | 74 | (345) | 95 |
| | | (25F) | 75 | (346) | 95 |
| | | (25G) | 75 | (347) | 95 |
| | | (25H) | 75 | (348) | 95 |
| | | (25I) | 75 | (351) | 96 |
| | | (25J) | 76 | (354) | 97 |
| | | (25K) | 76 | (361) | 98 |
| | | (25L) | 76 | (362) | 98 |
| | | (25M) | 76 | (363) | 98 |
| | | (25N) | 71, 76 | (364) | 98 |
| | | (25O) | 76 | (365) | 98 |
| | | (25Q) | 77 | (366) | 98 |
| | | (25R) | 77 | (367) | 98 |
| | | (25S) | 77 | (368) | 98 |
| | | (25T) | 77 | (369) | 99 |
| | | (25U) | 78 | (371) | 99 |
| | | (260) | 78 | (372) | 100 |
| | | (261) | 78 | (373) | 100 |
| | | (262) | 78 | (380) | 100 |
| | | (2621) | 78 | (381) | 100 |
| | | (2622) | 79 | (383) | 100 |
| | | (263) | 79 | (384) | 101 |
| | | (2631) | 79 | (385) | 101 |
| | | (2632) | 79 | (386) | 101 |
| | | (2633) | 79 | (387) | 101 |
| | | (2634) | 79 | (388) | 102 |
| | | (264) | 80 | (389) | 102 |
| | | (265) | 80 | (391) | 104 |
| | | (269) | 81 | (392) | 104 |
| | | (310) | 81 | (393) | 104 |
| | | (320) | 82 | (394) | 105 |
| | | (321) | 82 | (395) | 105 |
| | | (322) | 83 | (396) | 105 |
| L | | | | | |
| LCD display | 45 | | | | |
| Level control | 39, 60 | | | | |
| Load default | 70 | | | | |
| Load monitor | 41, 113 | | | | |
| Local/Remote | 59 | | | | |
| Lock code | 60 | | | | |
| Long motor cables | 18 | | | | |
| Low Voltage Directive | 7 | | | | |
| Lower Band | 106 | | | | |
| Lower Band Limit | 107 | | | | |
| M | | | | | |
| Machine Directive | 7 | | | | |
| Main menu | 49 | | | | |
| Mains supply | 16, 23, 29 | | | | |
| Maintenance | 170 | | | | |
| Manis cables | 15 | | | | |
| Max Frequency | 86, 94 | | | | |
| Memory | 40 | | | | |
| Menu | | | | | |
| (110) | 55 | | | | |
| (120) | 56 | | | | |
| (210) | 56 | | | | |
| (211) | 56 | | | | |
| (212) | 57 | | | | |
| (213) | 57 | | | | |
| (214) | 58 | | | | |
| (215) | 58 | | | | |
| (216) | 59 | | | | |
| (217) | 59 | | | | |
| (218) | 60 | | | | |
| (219) | 60 | | | | |
| (21A) | 60 | | | | |
| (21B) | 61 | | | | |
| (220) | 61 | | | | |
| (221) | 61 | | | | |
| (222) | 62 | | | | |
| (223) | 62 | | | | |
| (224) | 62 | | | | |
| (225) | 62 | | | | |
| (226) | 63 | | | | |
| (227) | 63 | | | | |
| (228) | 63 | | | | |
| (229) | 64 | | | | |
| (22B) | 64 | | | | |
| (22C) | 64 | | | | |
| (22D) | 64 | | | | |
| (230) | 65 | | | | |

| | | | | | |
|-----------------|---------|-----------------|----------|------------------------------------|----------|
| (398) | 106 | (55D) | 135 | (716) | 154 |
| (399) | 106 | (561) | 135 | (717) | 154 |
| (39A) | 107 | (562) | 136 | (718) | 155 |
| (39B) | 107 | (563-56G) | 136 | (719) | 155 |
| (39C) | 107 | (610) | 136 | (71A) | 155 |
| (39D) | 107 | (6111) | 137 | (71B) | 155 |
| (39E) | 108 | (6112) | 139 | (720) | 156 |
| (39F) | 108 | (6113) | 141 | (721) | 156 |
| (39G) | 109 | (6114) | 141 | (722) | 156 |
| (39H-39M) | 109 | (6115) | 141 | (723) | 157 |
| (410) | 113 | (6121) | 142 | (724) | 157 |
| (411) | 113 | (6122) | 142 | (725) | 157 |
| (412) | 113 | (6123) | 142 | (726) | 158 |
| (413) | 114 | (6124) | 143 | (727) | 158 |
| (414) | 114 | (6125) | 143 | (728-72A) | 158 |
| (415) | 114 | (6131) | 143 | (730) | 159 |
| (416) | 115 | (6132) | 143 | (731) | 159 |
| (4162) | 115 | (6133) | 144 | (7311) | 159 |
| (417) | 115 | (6134) | 144 | (732) | 159 |
| (4171) | 115 | (6135) | 144 | (733) | 159 |
| (4172) | 115 | (6141) | 144 | (7331) | 160 |
| (418) | 115 | (6142) | 145 | (800) | 160 |
| (4181) | 115 | (6143) | 145 | (810) | 160 |
| (4182) | 116 | (6144) | 145 | (811-81N) | 161 |
| (419) | 116 | (6145) | 145 | (820) | 161 |
| (4191) | 116 | (6151) | 146 | (830) | 161 |
| (4192) | 116 | (6152) | 146 | (8A0) | 162 |
| (41A) | 116 | (6153) | 146 | (900) | 162 |
| (41B) | 117 | (6154) | 146 | (920) | 162 |
| (41C) | 117 | (620) | 147 | (922) | 162 |
| (421) | 118 | (621) | 147, 148 | 33F | 92 |
| (422) | 118 | (622) | 147, 148 | 616 | 142 |
| (423) | 118 | (623) | 147, 148 | Minimum Frequency | 88 |
| (424) | 119 | (624) | 147 | Monitor function | |
| (511) | 119 | (625) | 147 | Alarm Select | 117 |
| (512) | 120 | (630) | 149 | Delay time | 114 |
| (513) | 121 | (631) | 149 | Max Alarm | 113 |
| (514) | 124 | (632) | 149 | Overload | 41, 113 |
| (515) | 124 | (633) | 150 | Response delay | 115, 117 |
| (516) | 124 | (634) | 150 | Start delay | 114 |
| (517) | 124 | (635) | 150 | Motor cables | 16 |
| (518) | 125 | (640) | 150 | Motor cos phi (power factor) | 63 |
| (519) | 125 | (641) | 150 | Motor data | 61 |
| (51A) | 125 | (642) | 151 | Motor frequency | 62 |
| (51B) | 125 | (643) | 151 | Motor I2t Current | 167 |
| (51C) | 125 | (644) | 151 | Motor identification run | 64 |
| (521) | 92, 126 | (645) | 151 | Motor Lost | 73 |
| (522) | 127 | (649) | 152 | Motor lost | 118 |
| (529-52H) | 127 | (650) | 152 | Motor Potentiometer | 98, 126 |
| (531) | 128 | (651) | 152 | Motor potentiometer | 126 |
| (532) | 128 | (652) | 152 | Motor ventilation | 63 |
| (533) | 129 | (653) | 152 | Motors | 5 |
| (534) | 131 | (654) | 152 | Motors in parallel | 21 |
| (535) | 131 | (655) | 153 | MotPot | 87 |
| (536) | 131 | (659) | 153 | | |
| (541) | 132 | (711) | 153 | N | |
| (542) | 134 | (712) | 153 | Nominal motor frequency | 94 |
| (551) | 134 | (713) | 154 | Number of drives | 104 |
| (552) | 134 | (714) | 154 | | |
| (553) | 134 | (715) | 154 | | |

| | | | |
|--|---------|---------------------------------------|--------|
| O | | | |
| Operation | 56 | Remote control | 37 |
| Options | 28, 171 | Reset command | 126 |
| Brake chopper | 172 | Reset control | 59 |
| External Control Panel (ECP) | 171 | Resolution | 55 |
| I/O Board | 173 | RFI mains filter | 16 |
| Output coils | 174 | Rotation | 60 |
| Protection class IP23 and IP54 | 171 | RS232/485 | 78 |
| Serial communication, fieldbus | 174 | RUN | 46 |
| OR operator | 147 | Run command | 47 |
| Output coils | 174 | Run Left command | 126 |
| Output Voltage | 154 | Run Right command | 126 |
| Overload | 41, 113 | Running motor | 89 |
| Overload alarm | 41 | | |
| P | | S | |
| Parameter sets | | Select Drive | 104 |
| Load default values | 70 | Settle Time | 107 |
| Load parameter sets from Control Panel | 71 | Setup menu | 49 |
| Parameter Set Selection | 35 | Menu structure | 48 |
| Select a Parameter set | 68 | Shaft power | 154 |
| PI Autotune | 99 | Signal ground | 192 |
| PID Controller | 100 | Single-ended connection | 27 |
| Closed loop PID control | 101 | Software | 162 |
| Feedback signal | 100 | Speed | 153 |
| PID D Time | 101 | Speed Mode | 57 |
| PID I Time | 101 | Spinstart | 89 |
| PID P Gain | 100 | Standards | 6 |
| Power LED | 46 | Start Delay | 106 |
| Priority | 36 | Start/Stop settings | 86 |
| Process Protection | 118 | Status indications | 45 |
| Process Value | 153 | Stop categories | 43 |
| Product standard, EMC | 6 | Stop command | 126 |
| Programming | 49 | Stop Delay | 107 |
| Protection class IP23 and IP54 | 171 | Stripping lengths | 20 |
| PT100 Inputs | 68 | Switches | 24 |
| PTC input | 67 | Switching in motor cables | 18 |
| Pump/Fan Control | 104 | | |
| | | T | |
| Q | | Technical Data | 179 |
| Quick Setup Card | 5 | Terminal connections | 24 |
| | | Test Run | 64 |
| R | | Timer | 105 |
| Reference | | Torque | 55, 96 |
| Frequency | 118 | Transition Frequency | 108 |
| Motor potentiometer | 126 | Trip | 46 |
| Reference signal | 57, 81 | Trip causes and remedial action | 166 |
| Set reference value | 81 | Trip Message log | 160 |
| Torque | 118 | Trips, warnings and limits | 165 |
| View reference value | 81 | Twisted cables | 28 |
| Reference control | 58 | Type code number | 5 |
| Reference signal | 58 | | |
| Relay output | 134 | U | |
| Relay 1 | 134 | Underload | 41 |
| Relay 2 | 134 | Underload alarm | 113 |
| Relay 3 | 134 | Unlock Code | 60 |
| Release speed | 91 | Upper Band | 106 |
| | | Menu | |
| | | (397) 106 | |
| | | Upper Band Limit | 107 |



TECO Electric & Machinery Co.,Ltd.
10F, No.3-1,Yuancyu St., Nangang District, Taipei City 115, Taiwan
Tel: +886-2-6615-9111, Fax: +886-2-6615-0933

Internet: www.teco.com.tw