

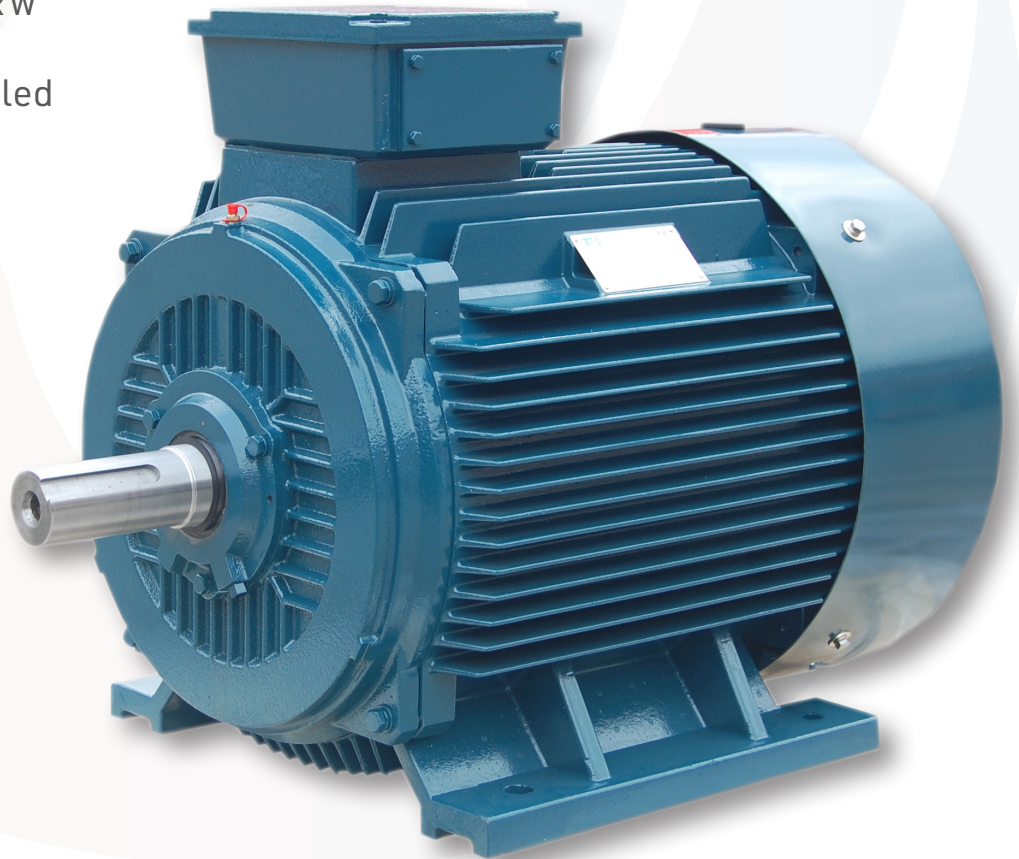

# TECO Australia and New Zealand Te3 Low Voltage 3-Phase Induction Motors

RANGE 0.55kW TO 500kW

Totally enclosed fan-cooled  
cast iron frame series



# Contents

Introduction	3
General information	4
Electrical design and standards	5
Mechanical design and standards	8
Typical performance data	10
Outline dimensions	12



# Rotating the World Sustainably and Reliably with TECO's Industrial Solutions.



## GLOBAL EXPERTISE WITH LOCAL SUPPORT

Operating in over 40 countries across all five continents.



## VAST STOCK AVAILABILITY

Large stock range across Australia & New Zealand.



## LOCAL IN-HOUSE WORKSHOP

Full range of mechanical and electrical modifications ensuring adherence to TECO's stringent QA standards.

**TECO is a global leader specialising in manufacturing and distribution of industrial Electric Motors and Variable Speed Drives.**

Our extensive product range includes high-quality Low & - Medium Voltage Motors from fractional kW to 22,000 kW for supplies up to 14,200 Volts, energy-efficient Variable Speed Drives and reliable automation equipment.

Our commitment to excellence is evident in our longstanding ISO 9001 and ISO 14001 certifications. Furthermore, our recent acquisition of the EPACT Energy Efficiency Certificate solidifies our position as an exemplary player in the global marketplace.

TECO's commitment to technological advancement and sustainable practice has earned a reputation for delivering superior products and exceptional customer service.

With TECO, you can trust in industry-leading performance, reliability, and a commitment to sustainable practices.



# General information

Te3 - Three Phase Induction Motors are a range of high quality, Totally Enclosed Fan Cooled (TEFC), Squirrel Cage Induction motors, designed, manufactured and tested to the latest International and Australian Standards.

For the Te3 range there are two main motor types:

MOTOR TYPES				
Types	Enclosure Protection	Insulation Class	Shaft seals	Finish Colour AS2700
Te3	IP55 (IP56 Upgrade Available)	F	"V" ring	TEAL T63
Te3 Severe Duty	IP66	H	Gamma	GLOSS BLUE JADE T24





# Electrical design and standards

## ALTITUDE

Designed for operation at an altitude up to 1000 metres above sea level (please refer to TECO sales offices for higher altitudes).

## AMBIENT

Motors are designed to operate in ambient conditions of -20°C to +50°C as standard. Operation in adverse ambient conditions should be referred to TECO.

## DIRECTION OF ROTATION

Standard rotation is clockwise when viewed from the drive end with the terminal markings corresponding to incoming line markings.

## DUTY RATING

All motors have a maximum continuous duty rating of S1 to IEC60034. Other duty ratings are available on request.

## ELECTRIC SUPPLY

Stock motors are designed for operation on a 380~415 Volt 3 phase 50 Hz supply and are also suitable for a 440~480 Volt 3 phase 60 Hz supply. Motors 3 kW and below are 380 - 415 Volt 50 Hz STAR connected and may also be reconnected to 240 Volt 3 phase 50 Hz DELTA configuration for use with single phase input Variable Speed Drives. Motors 4 kW and larger are 380 - 415 Volt 50 Hz DELTA connected. Motors can be manufactured for supply systems of up to 1100 Volts, 50 or 60 Hz on a factory made to order basis or local rewind.

## MOTOR TYPES / MEPS (MINIMUM EFFICIENCY PERFORMANCE STANDARD)

All motors meet or exceed the Minimum Efficiency level requirements of the Australian / New Zealand MEPS and IEC60034-30 Standard where applicable.

## VARIABLE SPEED DRIVE (VSD) SUITABILITY

Motors are suitable for VSD duty, subject to torque and speed limitations depending on the load characteristics and correct installation of motor and drive. EDM protection can be provided as a modification when requested.

Typical Motor Loadability Curves For VSD Duty

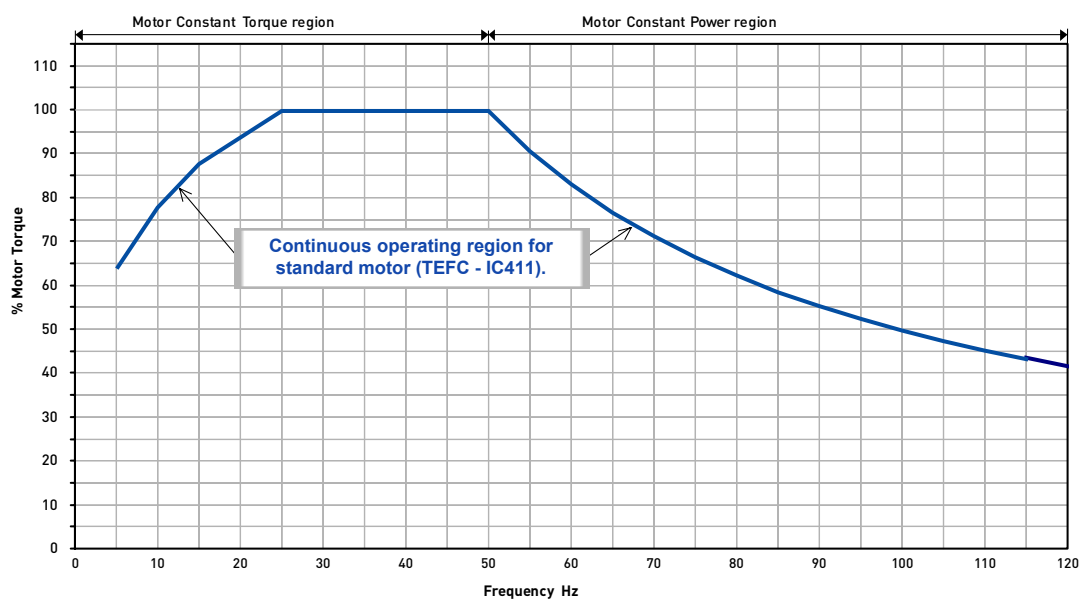

- Notes: 1. The electrical installation must have an adequate grounding and follow the guidelines detailed in AS60034.17 and IEC60034.25 Standards.  
2. Maximum safe operating speed to follow IEC60034 Table 17.

# Electrical design and standards

For variable torque loads (centrifugal pumps and fans) for speeds between 5-50 Hz derating is not normally required. Outside of this range please check with TECO for motor suitability.

Typical variable and constant torque load curves are shown below:

Speed vs. Torque Curves (assuming load torque at 100% speed = motor full load torque)

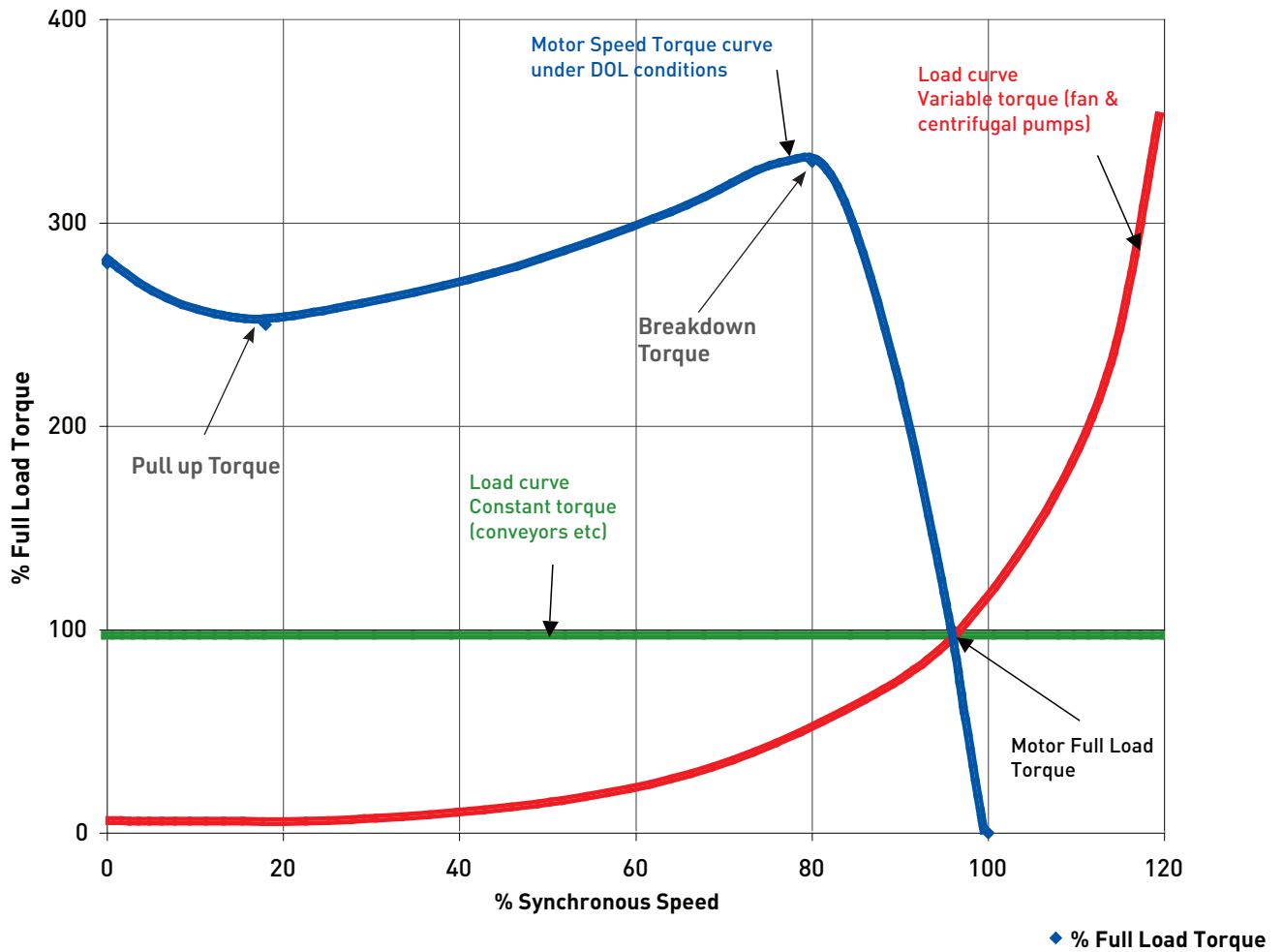

Maximum Safe Operating Speeds (AS60034-1 Table 17)

SAFE OPERATING SPEEDS			
Frame Number	2 Pole	4 Pole	6 Pole
≤ 112	5200	3600	2400
132 ~ 180	4500	2700	2400
200	4500	2300	1800
225-315	3600	2300	1800

Note: Motors are balanced to 3600rpm for 2 pole motors, and 1800rpm for 4 or more poles. If the motor operation is above the respective balancing speed, a special balance may be required (please refer to TECO).

## PERFORMANCE

Motors are designed to meet the performance requirements of Design N as per IEC60034, normal torque for Direct On Line starting. Motors are also suitable for other means of starting, depending on load characteristics, please refer to TECO.

Motors can be manufactured to provide special performance characteristics to suit specific applications as required.

## STANDARDS

Motors are designed, manufactured and tested in accordance with IEC60034, IEC60072.

## STATOR WINDINGS

High grade insulated cold rolled electro magnetic steel laminations.

Standard insulation is Class F insulation (155°C) with the Severe Duty model utilising full Class H materials (180°C).

Windings are designed with a maximum temperature rise of class B for long motor life and thermal reserve for abnormal conditions.

Windings are random wound double enamelled copper wire, impregnated with a solventless resin and all motors are tropicalised as standard.

## TESTING

In addition to a full program of tests during manufacture each motor is subjected to routine tests to IEC60034 prior to despatch from the factory.

## WINDING PROTECTION

Single speed motors frame sizes D160 and larger are fitted with PTC thermistor protection (P140) within the windings, one per phase, connected in series with the leads terminated in the main terminal box, if a separate terminal box is required please advise TECO.





# Mechanical design and standards

## BALANCE

All rotors are dynamically balanced with a half key to grade G2.5 according to ISO21940 standard, so the motor vibration complies with grade A of IEC60034-14 standard.

BEARING AND LUBRICATION SYSTEM				
Frame size	Poles	DE Bearing	NDE Bearing	Greasing
D80 ~ D160	All	Ball	Ball	Greased for life
D180 ~ D400	All	Ball	Ball	Grease relief

## NOTES:

- 2 Pole motors up to D180 are suitable for direct drive or belt drive.
- For 2 pole motors D200 frame and above are suitable for direct drive. For belt applications please refer to TECO.
- 4 to 8 pole motors, up to and including D400, are suitable for direct drive only. For other applications, please refer to TECO with drive details for correct bearing selection.
- Grease Relief system enables motor to be re-greased during operation.
- V-ring shaft seals are standard but metal backed Gamma seals are used on the Severe Duty models.

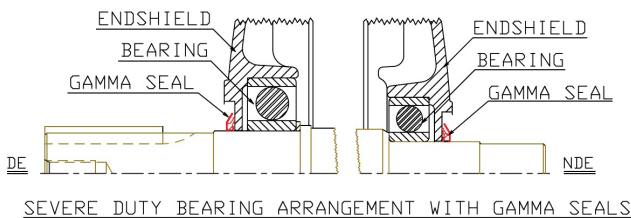
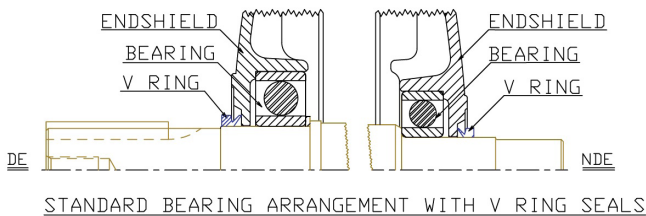

## COOLING SYSTEM

Cooling is Totally Enclosed Fan Cooled (TEFC), with integrally cast cooling fins on the frame. Each motor is also fitted with an external fan (IC411) to IEC60034.

The cooling fans are bi-directional and low noise as standard (larger 2 pole may have uni-directional fans for low noise).

## FINISH

All castings are mechanically cleaned and de-greased. Cast Iron components are primed internally and externally with anti-rust primer paint. Two finish coats of matt acrylic resin are applied providing a high corrosion protected surface. Finish colour TEAL T63 (standard), GLOSS BLUE JADE T24 (Severe Duty), colours are to AS2700.

## HARDWARE

All hardware is electro zinc plated for better corrosion resistance. Stainless steel hardware can be offered as an alternative, please contact TECO for the surcharge to provide this feature.

## MOUNTING

Motors are available in the following mountings:

- Foot mounted
- Foot and Flange mounted
- Flange mounted
- Foot and C Face mounted
- C Face mounted

## MOTOR CONSTRUCTION

- Cast Iron frame with integrally cast feet and cast iron end shields.
- Castings are machined to close tolerances for accurate alignment and minimum vibration.
- External cooling fan is polypropylene and larger size motors utilize metallic fans.
- Fan cover is heavy duty pressed steel.

## ROTOR ASSEMBLY

- High grade insulated cold rolled electro magnetic steel laminations.
- Rotor cage is pressure die cast high conductivity aluminium with fins and balance supports integrally cast onto the rotor endrings.
- The rotor is pressed and keyed (on larger motors) to a high tensile steel shaft.

## TERMINAL BOX

- Terminal box is top mounted on motor frame with all metal to metal joints provided with neoprene gaskets.
- Base - Lid surfaces are machined and fitted with one-piece neoprene gasket providing terminal boxes with an IP66 rating and has a "wrap over" casting on lid to protect the motor from moisture ingress.
- Terminal box can be rotated in 90° steps through 360° for alternate cable entry orientations.

## RATING PLATE

- A stainless steel rating plate containing all details as specified in IEC60034 including bearing sizes is fitted to all motors.

## OPTIONS

Some available options in this range are as follows:

- Airstream rated IC418
- Anti-condensation heaters
- Auxiliary terminal boxes for Thermistor / Heater / RTD terminations
- Cooling Tower application
- Double / non standard shaft extensions
- Electromechanical "fail safe" Brake Motors
- Encoder / Tacho
- Force cooling IC416
- Insulated bearing
- IP56, IP65 & IP66 enclosure
- Resistance temperature detectors (RTD's) winding and/or bearing
- Rotor Groundary brush
- Special paint systems / colours
- Stainless steel fasteners
- Thermistor protection (on motor frames <D160 or additional sets)
- Others on request



TYPICAL PERFORMANCE DATA

CAST IRON TEFC THREE PHASE SQUIRREL CAGE INDUCTION MOTORS  
Te3 RANGE 80 - 400L FRAME (415V 50Hz)

OUT PUT kW	FULL LOAD SPEED RPM	IEC FRAME	EFFICIENCY			POWER FACTOR			CURRENT		TORQUE			NOISE dB(A)	INERTIA Rotor J=GD <sup>2</sup> /4	WEIGHT Foot Mount kg
			Full Load %	3/4 Load %	1/2 Load %	Full Load cos φ	3/4 Load cos φ	1/2 Load cos φ	Full Load A	Locked Rotor /FLC	Full Load Nm	Locked Rotor /FLT	Break-down /FLT			
<b>2 Pole</b>																
0.75	2855	80M	80.9	81.4	79.5	0.82	0.75	0.62	1.57	7.0	2.51	2.3	2.3	62	0.0010	20
1.1	2860	80M	83.0	84.8	83.4	0.83	0.76	0.64	2.22	7.3	3.67	2.2	2.3	62	0.0013	21
1.5	2885	90S	84.3	85.2	83.6	0.84	0.79	0.69	2.95	7.6	4.97	2.2	2.3	67	0.0018	25
2.2	2885	90L	86.1	87.0	86.1	0.85	0.81	0.71	4.18	7.6	7.28	2.2	2.3	67	0.0024	30
3	2890	100L	87.2	88.2	88.0	0.87	0.86	0.78	5.50	7.8	9.91	2.2	2.3	68	0.0041	38
4	2905	112M	88.1	87.7	86.9	0.88	0.85	0.76	7.18	8.3	13.1	2.2	2.3	68	0.0059	48
5.5	2910	132S	89.4	89.9	89.1	0.88	0.85	0.77	9.73	8.3	18.0	2.0	2.3	72	0.0131	66
7.5	2915	132S	90.3	90.2	89.2	0.88	0.86	0.80	13.1	7.9	24.6	2.0	2.3	72	0.0154	72
11	2935	160M	91.3	91.1	90.4	0.89	0.88	0.83	18.8	8.1	35.8	2.0	2.3	72	0.0498	122
15	2935	160M	92.0	92.1	91.0	0.89	0.88	0.84	25.5	8.1	48.8	2.0	2.3	72	0.0572	130
18.5	2935	160L	92.5	91.9	91.0	0.89	0.89	0.84	31.3	8.2	60.2	2.0	2.3	72	0.0661	147
22	2940	180M	92.8	92.4	91.2	0.89	0.89	0.84	37.1	8.2	71.5	2.0	2.3	74	0.0825	172
30	2955	200L	93.4	92.7	92.0	0.89	0.89	0.86	50.2	7.6	97.0	2.0	2.3	75	0.166	247
37	2955	200L	93.8	93.4	92.3	0.89	0.89	0.85	61.7	7.6	120	2.0	2.3	75	0.176	256
45	2970	225M	94.2	94.1	93.9	0.90	0.89	0.86	73.8	7.7	145	2.0	2.3	78	0.306	331
55	2970	250M	94.4	94.5	93.7	0.90	0.90	0.86	90.1	7.7	177	2.0	2.3	80	0.430	414
75	2975	250M**	94.7	94.7	93.9	0.87	0.87	0.82	127	8.5	241	2.5	2.5	80	0.474	438
75	2980	280S	94.7	94.6	93.7	0.90	0.89	0.84	122	7.1	240	1.8	2.3	82	0.568	502
90	2980	280M	95.1	95.0	93.0	0.90	0.90	0.88	146	7.1	288	1.8	2.3	82	0.664	523
110	2980	280M**	95.2	95.4	94.9	0.89	0.89	0.88	181	8.1	352	2.0	2.5	82	0.78	619
110	2980	315S	95.2	95.1	93.1	0.90	0.90	0.89	179	7.1	353	1.8	2.3	83	1.23	858
132	2980	315M	95.5	95.4	94.1	0.90	0.89	0.84	214	7.1	423	1.8	2.3	84	1.39	957
160	2980	315L	95.6	95.5	94.3	0.91	0.89	0.84	256	7.2	513	1.8	2.3	86	1.54	1011
200	2980	315L	95.8	95.8	95.2	0.91	0.90	0.84	319	7.2	641	1.8	2.2	87	1.72	1056
250	2980	355M	95.8	95.8	95.2	0.91	0.90	0.90	399	7.2	801	1.6	2.2	90	3.73	1850
315	2980	355L	95.8	95.8	95.3	0.91	0.90	0.85	503	7.2	1009	1.6	2.2	90	4.64	1950
<b>4 Pole</b>																
0.55	1425	80M	80.8	80.8	78.2	0.75	0.65	0.53	1.26	6.5	3.69	2.3	2.3	56	0.0017	20
0.75	1425	80M	82.9	82.9	79.3	0.75	0.66	0.53	1.68	6.6	5.03	2.3	2.3	56	0.0020	22
1.1	1425	90S	84.3	84.2	82.0	0.76	0.67	0.55	2.39	6.8	7.37	2.3	2.3	59	0.0027	26
1.5	1425	90L	85.5	85.6	83.6	0.77	0.68	0.55	3.17	7.0	10.1	2.3	2.3	59	0.0034	30
2.2	1440	100L	86.8	86.2	84.5	0.81	0.73	0.61	4.35	7.6	14.6	2.3	2.3	60	0.0070	39
3	1445	100L	87.9	87.1	84.6	0.82	0.71	0.59	5.79	7.6	19.8	2.3	2.3	60	0.0090	43
4	1445	112M	88.6	88.2	86.5	0.82	0.72	0.59	7.66	7.8	26.4	2.2	2.3	60	0.0121	55
5.5	1455	132S	89.7	89.7	88.2	0.83	0.77	0.68	10.3	7.9	36.1	2.0	2.3	62	0.0241	70
7.5	1455	132M	90.4	90.4	89.4	0.84	0.78	0.68	13.7	7.5	49.2	2.0	2.3	62	0.0310	81
11	1465	160M	91.5	91.7	91.3	0.85	0.80	0.71	19.7	7.7	71.7	2.2	2.3	64	0.0798	122
15	1465	160L	92.2	92.1	92.1	0.86	0.80	0.72	26.3	7.8	97.8	2.2	2.3	64	0.105	147
18.5	1470	180M	92.6	92.3	91.9	0.86	0.85	0.77	32.3	7.8	120	2.0	2.3	65	0.156	174
22	1470	180L	93.1	93.0	91.0	0.86	0.85	0.77	38.2	7.8	143	2.0	2.3	65	0.191	199
30	1475	200L	93.7	93.6	93.0	0.86	0.84	0.78	51.8	7.3	194	2.0	2.3	66	0.292	254
37	1480	225S	93.9	93.8	93.2	0.86	0.84	0.79	63.7	7.4	239	2.0	2.3	68	0.486	298
45	1480	225M	94.2	94.3	94.0	0.86	0.85	0.80	77.3	7.4	290	2.0	2.3	68	0.568	331
55	1480	250M	94.6	94.9	94.4	0.86	0.86	0.81	94.1	7.4	355	2.2	2.3	70	0.761	413
75	1485	250M**	95.0	94.5	93.4	0.87	0.83	0.75	126	6.9	482	2.0	2.3	72	0.788	455
75	1485	280S	95.2	95.2	95.0	0.88	0.84	0.76	125	6.9	482	2.0	2.3	72	1.38	554
90	1485	280M	95.5	95.5	94.5	0.88	0.84	0.77	149	6.9	579	2.0	2.3	72	1.70	641
110	1485	280M**	95.6	95.4	94.6	0.89	0.85	0.78	184	7.1	707	2.0	2.3	78	1.64	660
110	1485	315S	95.6	95.8	95.2	0.89	0.89	0.84	180	7.0	707	2.0	2.2	78	2.33	879
132	1485	315M	95.7	95.5	94.7	0.89	0.88	0.84	216	7.0	849	2.0	2.2	78	2.56	970
160	1485	315L	95.9	95.9	95.1	0.89	0.88	0.80	261	7.1	1029	2.0	2.2	78	2.94	1149
200	1485	315L	96.0	96.2	96.0	0.89	0.88	0.84	326	7.1	1286	2.0	2.2	80	3.43	1250
250	1490	355M	96.0	96.0	95.1	0.90	0.89	0.89	403	7.1	1602	2.0	2.2	85	6.54	1702
315	1490	355L	96.0	96.0	95.1	0.90	0.89	0.83	507	7.1	2019	2.0	2.2	85	7.44	1829



## TYPICAL PERFORMANCE DATA

### CAST IRON TEFC THREE PHASE SQUIRREL CAGE INDUCTION MOTORS Te3 RANGE 80 - 400L FRAME (415V 50HZ)

OUT PUT kW	FULL LOAD SPEED RPM	IEC FRAME	EFFICIENCY			POWER FACTOR			CURRENT		TORQUE			NOISE dB(A)	INERTIA Rotor J=GD <sup>2</sup> /4	WEIGHT Foot Mount kg
			Full Load %	3/4 Load %	1/2 Load %	Full Load cos φ	3/4 Load cos φ	1/2 Load cos φ	Full Load A	Locked Rotor /FLC	Full Load Nm	Locked Rotor /FLT	Break-down /FLT			
<b>6 Pole</b>																
0.37	925	80M	73.5	72.4	68.2	0.68	0.57	0.45	1.03	6.0	3.82	2.0	2.1	54	0.0020	20
0.55	930	80M	77.2	68.5	65.7	0.68	0.61	0.47	1.46	6.0	5.65	2.0	2.1	54	0.0027	22
0.75	940	90S	79.3	79.4	75.8	0.71	0.59	0.47	1.85	6.0	7.62	2.0	2.1	57	0.0036	25
1.1	940	90L	81.2	82.1	81.1	0.73	0.63	0.51	2.58	6.0	11.2	2.0	2.1	57	0.0049	29
1.5	950	100L	82.5	82.4	79.1	0.73	0.62	0.50	3.47	6.5	15.1	2.0	2.1	61	0.0107	38
2.2	955	112M	84.3	84.6	83.4	0.74	0.67	0.56	4.91	6.6	22.0	2.0	2.1	62	0.0155	51
3	970	132S	85.7	86.2	84.5	0.74	0.67	0.55	6.58	6.8	29.5	2.0	2.1	62	0.0281	64
4	970	132M	86.8	87.9	87.7	0.74	0.69	0.56	8.66	6.8	39.4	2.0	2.1	62	0.0356	72
5.5	970	132M	88.1	88.0	86.3	0.75	0.66	0.55	11.6	7.0	54.1	2.0	2.1	62	0.0473	82
7.5	970	160M	89.3	89.9	89.5	0.79	0.74	0.64	14.8	7.0	73.8	2.0	2.1	63	0.0984	119
11	970	160L	90.4	90.7	90.0	0.80	0.71	0.60	21.2	7.2	108	2.0	2.1	63	0.130	143
15	980	180L	91.4	90.4	88.7	0.81	0.79	0.70	28.2	7.3	146	2.0	2.1	63	0.206	178
18.5	980	200L	91.9	91.5	90.8	0.81	0.78	0.72	34.6	7.3	180	2.0	2.1	65	0.333	231
22	980	200L	92.2	92.0	91.3	0.81	0.80	0.74	41.0	7.4	214	2.0	2.1	65	0.380	242
30	985	225M	92.9	93.0	92.3	0.83	0.81	0.73	54.1	6.9	291	2.0	2.1	66	0.546	288
37	985	250M	93.4	92.8	91.8	0.84	0.83	0.75	65.6	7.1	359	2.0	2.1	68	0.900	381
45	985	280S	93.9	94.0	93.9	0.85	0.83	0.75	78.4	7.3	436	2.0	2.0	68	1.46	493
55	985	280M	94.3	94.8	94.2	0.86	0.84	0.80	94.4	7.3	533	2.0	2.0	68	1.81	552
75	985	315S	94.7	94.6	93.3	0.84	0.80	0.73	131	6.6	727	2.0	2.0	71	2.59	785
90	985	315M	94.9	95.0	94.5	0.85	0.83	0.76	155	6.7	873	2.0	2.0	71	3.01	914
110	985	315L	95.2	95.3	94.4	0.85	0.83	0.76	189	6.7	1066	2.0	2.0	71	3.67	998
132	985	315L	95.5	95.8	95.0	0.86	0.85	0.79	224	6.8	1280	2.0	2.0	72	4.20	1059
160	990	355M	95.7	95.8	95.4	0.86	0.86	0.80	270	6.8	1543	1.8	2.0	75	7.41	1564
200	990	355M	95.9	95.8	95.2	0.87	0.87	0.82	334	6.8	1929	1.8	2.0	75	8.22	1632
250	990	355L	95.9	95.9	95.2	0.87	0.86	0.81	417	6.8	2412	1.8	2.0	75	9.87	1734
<b>8 Pole</b>																
0.18	680	80M	58.7	57.1	51.7	0.58	0.55	0.43	0.74	4.0	2.53	1.8	2.0	52	0.0020	20
0.25	680	80M	64.1	61.6	55.4	0.63	0.56	0.42	0.86	4.0	3.51	1.8	2.0	52	0.0027	22
0.37	695	90S	69.3	68.8	65.2	0.65	0.56	0.41	1.14	5.0	5.08	1.8	2.0	54	0.0036	28
0.55	695	90L	73.0	74.4	71.3	0.65	0.51	0.39	1.61	5.0	7.56	1.8	2.0	54	0.0049	30
0.75	710	100L	75.3	75.9	72.9	0.65	0.58	0.44	2.13	5.5	10.1	1.8	2.0	51	0.0092	36
1.1	710	100L	77.7	79.3	77.5	0.65	0.59	0.45	3.03	5.5	14.8	1.8	2.0	51	0.0121	40
1.5	705	112M	80.1	80.9	79.5	0.69	0.61	0.47	3.78	5.5	20.3	2.0	2.1	52	0.0166	51
2.2	710	132S	82.1	82.9	81.9	0.70	0.65	0.51	5.33	6.0	29.6	2.0	2.1	54	0.0302	62
3	710	132M	83.8	84.7	83.2	0.71	0.62	0.49	7.01	6.0	40.4	2.0	2.1	54	0.0385	71
4	710	160M	84.8	88.0	87.5	0.73	0.69	0.60	8.99	6.0	53.8	2.0	2.1	56	0.0630	93
5.5	715	160M	86.3	88.2	87.7	0.73	0.70	0.58	12.1	6.0	73.5	2.0	2.1	56	0.0857	108
7.5	715	160L	87.4	88.6	87.8	0.74	0.71	0.59	16.1	6.0	100	2.0	2.1	56	0.118	134
11	730	180L	88.8	89.0	88.6	0.76	0.72	0.62	22.7	6.5	144	2.0	2.1	63	0.219	177
15	730	200L	90.2	90.3	89.4	0.76	0.74	0.63	30.4	6.5	196	1.9	2.1	65	0.393	238
18.5	730	225S	90.3	90.7	90.0	0.76	0.69	0.57	37.5	6.5	242	1.9	2.1	65	0.541	268
22	730	225M	90.7	90.8	90.7	0.77	0.72	0.61	43.8	6.5	288	1.9	2.1	65	0.641	300
30	735	250M	91.5	91.8	90.7	0.77	0.71	0.60	59.2	6.5	390	1.9	2.1	65	0.937	388
37	740	280S	91.9	92.2	91.0	0.77	0.74	0.64	72.7	6.5	478	1.8	2.0	65	1.52	497
45	740	280M	92.3	93.6	92.5	0.77	0.76	0.66	88.1	6.5	581	1.8	2.0	65	1.81	549
55	740	315S	92.6	93.6	92.4	0.79	0.73	0.62	105	6.5	710	1.8	2.0	70	2.93	758
75	740	315M	93.1	94.2	93.3	0.79	0.75	0.65	142	6.5	968	1.8	2.0	70	3.93	930
90	740	315L	93.5	94.2	93.8	0.80	0.77	0.68	167	6.5	1161	1.8	2.0	70	4.63	1005
110	740	315L	93.8	94.8	94.4	0.81	0.79	0.72	201	6.5	1420	1.8	2.0	70	5.35	1075
132	740	355M	95.1	95.5	94.7	0.82	0.78	0.67	235	6.5	1704	1.8	2.0	75	8.28	1700
160	740	355M	94.3	94.8	94.5	0.82	0.79	0.72	288	6.5	2065	1.8	2.0	75	9.49	1750
200	740	355L	94.7	95.3	95.1	0.82	0.81	0.75	358	6.5	2581	1.8	2.0	75	10.4	1850

Notes: 1. Output at 415V also suitable for 380V and 400V operation at 50Hz. For 380V multiply full load current by 1.092. For 400V multiply full load current by 1.0375. 2. Efficiency test: IEC60034-2-1 Methods 2-1-1B. 3. Tolerance: AS60034.1 4. Noise is Sound Pressure Level at no load and 1 metre.

# OUTLINE DIMENSIONS

## CAST IRON TEFC THREE PHASE SQUIRREL CAGE INDUCTION MOTORS Te3 FRAMES 80 - 400L FOOT MOUNT

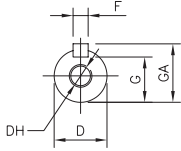

SHAFT DETAIL

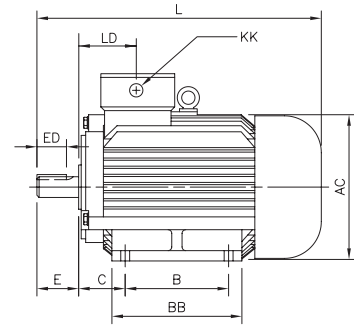
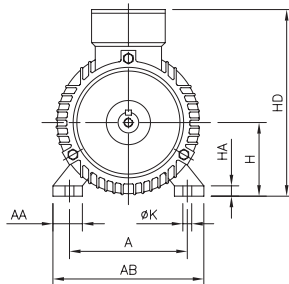

OUTPUT kW				FRAME SIZE	A	AA	AB	AC	B	BB	C	H	HA	HD
2P	4P	6P	8P											
0.75/1.1	0.55/0.75	0.55	-	80	125	34	160	180	100	130	50	80	10	235
1.5	1.1	0.75	-	90S	140	36	180	185	100	180	56	90	12	255
2.2	1.5	1.1	-	90L	140	36	180	185	125	155	56	90	12	255
3	2.2/3	1.5	0.75/1.1	100L	160	40	200	210	140	176	63	100	14	280
4	4	2.2	1.5	112M	190	45	230	220	140	180	70	112	15	305
5.5/7.5	5.5	3	2.2	132S	216	55	270	275	140	186	89	132	18	345
-	7.5	4/5.5	3	132M	216	55	270	275	178	224	89	132	18	345
11/15	11	7.5	4/5.5	160M	254	65	320	315	210	304	108	160	20	425
18.5	15	11	7.5	160L	254	65	320	315	254	334	108	160	20	425
22	18.5	-	-	180M	279	70	355	355	241	311	121	180	22	460
-	22	15	11	180L	279	70	355	355	279	349	121	180	22	460
30/37	30	18.5/22	15	200L	318	70	390	400	305	370	133	200	25	510
-	37	-	18.5	225S	356	75	431	450	286	368	149	225	28	560
45	-	-	-	225M	356	75	431	450	311	393	149	225	28	560
-	45	30	22	225M	356	75	431	450	311	393	149	225	28	560
55	-	-	-	250M	406	80	490	500	349	445	168	250	30	620
-	55	37	30	250M	406	80	490	500	349	445	168	250	30	620
-	75**	-	-	250M	406	80	490	500	349	445	168	250	30	620
75	-	-	-	280S	457	85	545	550	368	485	190	280	35	680
-	75	45	37	280S	457	85	545	550	368	485	190	280	35	680
90/110**	-	-	-	280M	457	85	545	550	419	536	190	280	35	680
-	90	55	45	280M	457	85	545	550	419	536	190	280	35	680
-	110**	-	-	280M	457	85	545	550	419	536	190	280	35	680
110	-	-	-	315S	508	120	630	630	406	570	216	315	45	850
-	110	75	55	315S	508	120	630	630	406	570	216	315	45	850
132	-	-	-	315M	508	120	630	630	457	680	216	315	45	850
-	132	90	75	315M	508	120	630	630	457	680	216	315	45	850
160/200	-	-	-	315L	508	120	630	630	508	680	216	315	45	850
-	160/200	110/132	90/110	315L	508	120	630	630	508	680	216	315	45	850
250	-	-	-	355M	610	120	730	710	560	750	254	355	52	1010
-	250(D)	160/200	132/160	355M	610	120	730	710	560	750	254	355	52	1010
-	250(B)	-	-	355M	610	120	730	710	560	750	254	355	52	1010
315	-	-	-	355L	610	120	730	710	630	750	254	355	52	1010
-	315(D)	250	200	355L	610	120	730	710	630	750	254	355	52	1010
-	315(B)	-	-	355L	610	120	730	710	630	750	254	355	52	1010
-	355/400 450/500	315/355 400/450	250/315 355	400L***	686	150	840	810	710	1075	280	400	55	1160

Notes: 1. Dimensional data subject to change without notice. 2. Lifting facilities provided on motors frame size D100 and larger. 3. For tolerances see page 11. 4. Bearing numbers in brackets apply to 2 pole motors. 5. \*\*Frame allocations available for 110kW 2 pole, 75kW 4 pole and 110kW 4 pole.

# OUTLINE DIMENSIONS

## CAST IRON TEFC THREE PHASE SQUIRREL CAGE INDUCTION MOTORS Te3 FRAMES 80 - 400L FOOT MOUNT

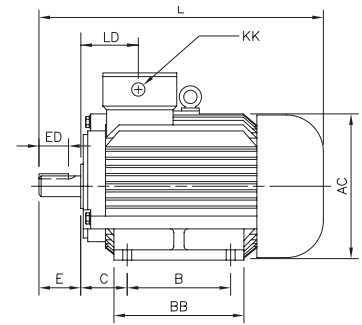
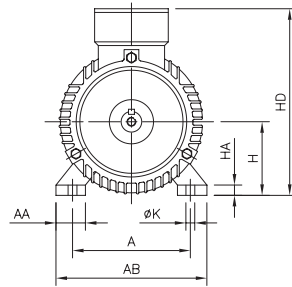
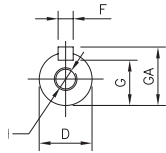

FRAME SIZE					SHAFT EXTENSION							BEARINGS	
	K	KK	L	LD	D	E	ED	F	G	GA	DH	DE	NDE
80	10	M25x1.5	300	72	19	40	22	6	15.5	21.5	M6x12	6204ZZ	6204ZZ
90S	10	M25x1.5	355	75	24	50	32	8	20	27	M8x16	6205ZZ	6205ZZ
90L	10	M25x1.5	385	75	24	50	32	8	20	27	M8x16	6205ZZ	6205ZZ
100L	12	M32x1.5	430	83	28	60	40	8	24	31	M10x20	6206ZZ	6206ZZ
112M	12	M32x1.5	460	87	28	60	40	8	24	31	M10x20	6206ZZ	6206ZZ
132S	12	M32x1.5	495	92	38	80	56	10	33	41	M12x24	6208ZZ	6208ZZ
132M	12	M32x1.5	535	92	38	80	56	10	33	41	M12x24	6208ZZ	6208ZZ
160M	14.5	M40x1.5	660	142	42	110	80	12	37	45	M16x32	6309ZZ(6209ZZ)	6209ZZ
160L	14.5	M40x1.5	690	142	42	110	80	12	37	45	M16x32	6309ZZ(6209ZZ)	6209ZZ
180M	14.5	M40x1.5	680	161	48	110	80	14	42.5	51.5	M16x32	6311(6211)	6211
180L	14.5	M40x1.5	718	161	48	110	80	14	42.5	51.5	M16x32	6311(6211)	6211
200L	18.5	M50x1.5	780	191	55	110	80	16	49	59	M20x40	6312(6212)	6212
225S(4-8)	18.5	M50x1.5	815	189	60	140	100	18	53	64	M20x40	6313	6312
225M(2)	18.5	M50x1.5	810	189	55	110	80	16	49	59	M20x40	6312	6312
225M(4-8)	18.5	M50x1.5	840	189	60	140	100	18	53	64	M20x40	6313	6312
250M(2)	24	BLANK	915	207	60	140	100	18	53	64	M20x40	6313	6313
250M(4-8)	24	BLANK	915	207	65	140	100	18	58	69	M20x40	6314	6313
250M(75kW)	24	BLANK	915	207	70	140	110	20	62.5	74.5	M20x40	6315	6313
280S(2)	24	BLANK	985	216	65	140	100	18	58	69	M20x40	6314	6314
280S(4-8)	24	BLANK	985	216	75	140	100	20	67.5	79.5	M20x40	6317	6314
280M(2)	24	BLANK	1040	216	65	140	100	18	58	69	M20x40	6314	6314
280M(4-8)	24	BLANK	1040	216	75	140	100	20	67.5	79.5	M20x40	6317	6314
280M(110kW)	24	BLANK	1040	216	80	170	140	22	71	85	M20x40	6317	6314
315S(2)	28	BLANK	1170	257	65	140	100	18	58	69	M20x40	6317	6317
315S(4-8)	28	BLANK	1235	257	80	170	130	22	71	85	M20x40	6319	6319
315M(2)	28	BLANK	1280	257	65	140	100	18	58	69	M20x40	6317	6317
315M(4-8)	28	BLANK	1345	257	80	170	130	22	71	85	M20x40	6319	6319
315L(2)	28	BLANK	1280	257	65	140	100	18	58	69	M20x40	6317	6317
315L(4-8)	28	BLANK	1315	257	80	170	130	22	71	85	M20x40	6319	6319
355M(2)	28	BLANK	1510	284	75	140	100	20	67.5	79.5	M20x40	6319	6319
355M(4-8)	28	BLANK	1590	284	95	170	130	25	85	99	M24x48	6322	6322
355M(250kW)	28	BLANK	1550	284	110	210	170	28	100	116	M24x48	6324	6322
355L(2)	28	BLANK	1510	284	75	140	100	20	67.5	79.5	M20x40	6319	6319
355L(4-8)	28	BLANK	1590	284	95	170	130	25	86	100	M24x48	6322	6322
355L(315kW)	28	BLANK	1550	284	110	210	170	28	100	116	M24x48	6324	6322
400L(4-8)	35	BLANK	1910	425	100	210	170	28	90	106	M24x48	6324	6324

Notes: 1. Dimensional data subject to change without notice. 2. Lifting facilities provided on motors frame size D100 and larger. 3. For tolerances see page 11. 4. Bearing numbers in brackets apply to 2 pole motors. 5. \*\*Frame allocations available for 110kW 2 pole, 75kW and 110kW 4 pole.



# OUTLINE DIMENSIONS

## CAST IRON TEFC THREE PHASE SQUIRREL CAGE INDUCTION MOTORS Te3 FRAMES 80 - 280M FLANGE MOUNT

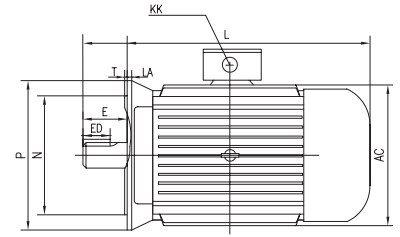
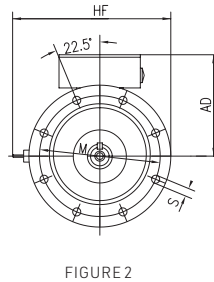
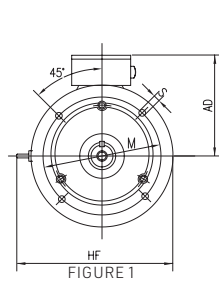
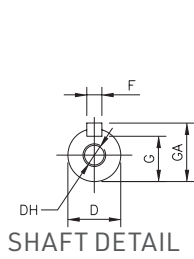

OUTPUT kW				FRAME SIZE	FIG. NO.	AC	AD	HF	L	LA	M	N	P	S	T
2P	4P	6P	8P												
0.75/1.1	0.55/0.75	0.55	-	80	1	180	160	200	300	12	165	130	200	12	3.5
1.5	1.1	0.75	-	90S	1	185	165	200	355	12	165	130	200	12	3.5
2.2	1.5	1.1	-	90L	1	185	165	200	385	12	165	130	200	12	3.5
3	2.2/3	1.5	0.75/1.1	100L	1	210	180	270	430	13	215	180	250	14.5	4
4	4	2.2	1.5	112M	1	220	200	275	460	14	215	180	250	14.5	4
5.5/7.5	5.5	3	2.2	132S	1	275	215	330	495	14	265	230	300	14.5	4
-	7.5	4/5.5	3	132M	1	275	215	330	535	14	265	230	300	14.5	4
11/15	11	7.5	4/5.5	160M	1	315	265	385	660	15	300	250	350	18.5	5
18.5	15	11	7.5	160L	1	315	265	385	690	15	300	250	350	18.5	5
22	18.5	-	-	180M	1	355	285	430	680	17	300	250	350	18.5	5
-	22	15	11	180L	1	355	285	430	718	17	300	250	350	18.5	5
30/37	30	18.5/22	15	200L	1	400	310	480	780	18	350	300	400	18.5	5
-	37	-	18.5	225S	2	450	340	535	815	20	400	350	450	18.5	5
45	-	-	-	225M	2	450	340	535	810	20	400	350	450	18.5	5
-	45	30	22	225M	2	450	340	535	840	20	400	350	450	18.5	5
55	-	-	-	250M	2	500	370	595	915	22	500	450	550	18.5	5
-	55	37	30	250M	2	500	370	595	915	22	500	450	550	18.5	5
75	-	-	-	280S	2	550	400	680	985	22	500	450	550	18.5	5
-	75	45	37	280S	2	550	400	680	985	22	500	450	550	18.5	5
90	-	-	-	280M	2	550	400	680	1040	22	500	450	550	18.5	5
-	90	55	45	280M	2	550	400	680	1040	22	500	450	550	18.5	5

FRAME SIZE	KK	SHAFT EXTENSION								BEARINGS	
		D	E	ED	F	G	GA	DH	DE	NDE	
80	M25x1.5	19	40	22	6	15.5	21.5	M6x12	6204ZZ	6204ZZ	
90S	M25x1.5	24	50	32	8	20	27	M8x16	6205ZZ	6205ZZ	
90L	M25x1.5	24	50	32	8	20	27	M8x16	6205ZZ	6205ZZ	
100L	M32x1.5	28	60	40	8	24	31	M10x20	6206ZZ	6206ZZ	
112M	M32x1.5	28	60	40	8	24	31	M10x20	6206ZZ	6206ZZ	
132S	M32x1.5	38	80	56	10	33	41	M12x24	6208ZZ	6208ZZ	
132M	M32x1.5	38	80	56	10	33	41	M12x24	6208ZZ	6208ZZ	
160M	M40x1.5	42	110	80	12	37	45	M16x32	6309ZZ(6209ZZ)	6209ZZ	
160L	M40x1.5	42	110	80	12	37	45	M16x32	6309ZZ(6209ZZ)	6209ZZ	
180M	M40x1.5	48	110	80	14	42.5	51.5	M16x32	6311(6211)	6211	
180L	M40x1.5	48	110	80	14	42.5	51.5	M16x32	6311(6211)	6211	
200L	M50x1.5	55	110	80	16	49	59	M20x40	6312(6212)	6212	
225S(4-8)	M50x1.5	60	140	100	18	53	64	M20x40	6313	6312	
225M(2)	M50x1.5	55	110	80	16	49	59	M20x40	6312	6312	
225M(4-8)	M50x1.5	60	140	100	18	53	64	M20x40	6313	6312	
250M(2)	BLANK	60	140	100	18	53	64	M20x40	6313	6313	
250M(4-8)	BLANK	65	140	100	18	58	69	M20x40	6314	6313	
280S(2)	BLANK	65	140	100	18	58	69	M20x40	6314	6314	
280S(4-8)	BLANK	75	140	100	20	67.5	79.5	M20x40	6317	6314	
280M(2)	BLANK	65	140	100	18	58	69	M20x40	6314	6314	
280M(4-8)	BLANK	75	140	100	20	67.5	79.5	M20x40	6317	6314	

## OUTLINE DIMENSIONS

### Te3 CAST IRON 3 - PHASE SQUIRREL CAGE INDUCTION MOTORS FRAME 80 - 250 FOOT MOUNT TOTALLY ENCLOSED AIR OVER MOTOR IC418 (AIRSTREAM RATED)

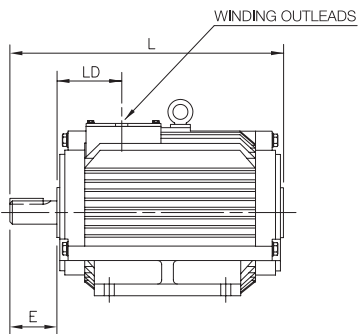

OUTPUT kW				FRAME SIZE	E	L	LD
2P	4P	6P	8P				
0.75/1.1	0.55/0.75	0.55	-	80	40	248	76
1.5	1.1	0.75	-	90S	50	300	75
2.2	1.5	1.1	-	90L	50	330	75
3	2.2/3	1.5	0.75/1.1	100L	60	380	83
4	4	2.2	1.5	112M	60	410	87
5.5/7.5	5.5	3	2.2	132S	80	430	102
-	7.5	4/5.5	3	132M	80	470	102
11/15	11	7.5	4/5.5	160M	110	522	142
18.5	15	11	7.5	160L	110	566	142
22	18.5	-	-	180M	110	587	164
-	22	15	11	180L	110	625	164
30/37	30	18.5/22	15	200L	110	660	191
-	37	-	18.5	225S	140	703	197
45	-	-	-	225M	110	698	197
-	45	30	22	225M	140	728	197
55	-	-	-	250M	140	790	215
-	55	37	30	250M	140	790	215

Notes: 1. Dimensional data subject to change without notice. 2. Lifting facilities provided on motors frame size D100 and larger. 3. For tolerances see page 11. 4. Bearing numbers in brackets apply to 2 pole motors.



# OUTLINE DIMENSIONS

## CAST IRON TEFC THREE PHASE SQUIRREL CAGE INDUCTION MOTORS Te3 FRAMES 80 - 400L FOOT AND "D" FLANGE MOUNT

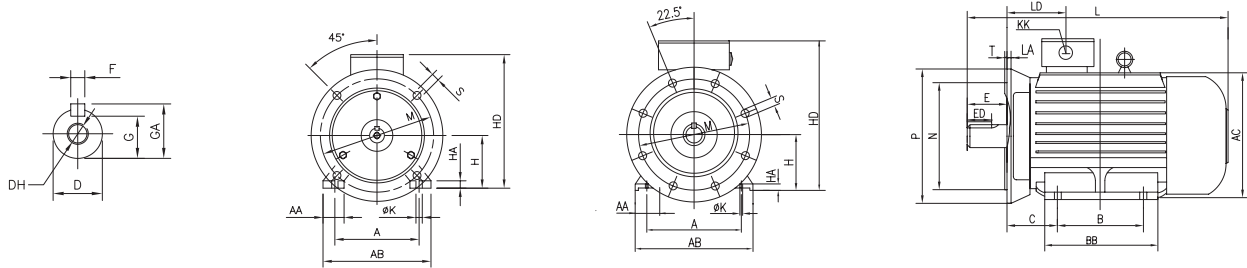

OUTPUT KW				FRAME SIZE	A	AA	AB	AC	B	BB	C	H	HA	HD	K	KK	L
2P	4P	6P	8P														
0.75/1.1	0.55/0.75	0.55	-	80	125	34	160	180	100	130	50	80	10	235	10	M25x1.5	300
1.5	1.1	0.75	-	90S	140	36	180	185	100	130	56	90	12	255	10	M25x1.5	355
2.2	1.5	1.1	-	90L	140	36	180	185	125	210	56	90	12	255	10	M25x1.5	385
3	2.2/3	1.5	0.75/1.1	100L	160	40	200	210	140	235	63	100	14	270	12	M32x1.5	430
4	4	2.2	1.5	112M	190	45	230	220	140	250	70	112	15	300	12	M32x1.5	465
5.5/7.5	5.5	3	2.2	132S	216	55	270	275	140	230	89	132	18	345	12	M32x1.5	510
-	7.5	4/5.5	3	132M	216	55	270	275	178	270	89	132	18	345	12	M32x1.5	550
11/15	11	7.5	4/5.5	160M	254	65	320	315	210	250	108	160	20	420	15	M40x1.5	615
18.5	15	11	7.5	160L	254	65	320	315	254	294	108	160	20	420	15	M40x1.5	670
22	18.5	-	-	180M	279	70	355	355	241	311	121	180	22	455	15	M40x1.5	700
-	22	15	11	180L	279	70	355	355	279	349	121	180	22	455	15	M40x1.5	740
30/37	30	18.5/22	15	200L	318	70	390	400	305	369	133	200	25	505	19	M50x1.5	770
-	37	-	18.5	225S	356	75	431	450	286	368	149	225	28	560	19	M50x1.5	815
45	-	-	-	225M	356	75	431	450	311	393	149	225	28	560	19	M50x1.5	820
-	45	30	22	225M	356	75	431	450	311	393	149	225	28	560	19	M50x1.5	845
55	-	-	-	250M	406	80	490	500	349	445	168	250	30	615	24	BLANK	910
-	55	37	30	250M	406	80	490	500	349	445	168	250	30	615	24	BLANK	910
-	75**	-	-	250M	406	80	490	500	349	445	168	250	30	615	24	BLANK	910
75	-	-	-	280S	457	85	545	550	368	530	190	280	35	700	24	BLANK	1000
-	75	45	37	280S	457	85	545	550	368	530	190	280	35	700	24	BLANK	1000
90	-	-	-	280M	457	85	545	550	419	581	190	280	35	700	24	BLANK	1050
-	90/110	55	45	280M	457	85	545	550	419	581	190	280	35	700	24	BLANK	1050
110	-	-	-	315S	508	120	630	630	406	616	216	315	45	815	28	BLANK	1178
-	110	75	45	315S	508	120	630	630	406	616	216	315	45	815	28	BLANK	1208
132	-	-	-	315M	508	120	630	630	457	676	216	315	45	815	28	BLANK	1238
-	132	90	75	315M	508	120	630	630	457	676	216	315	45	815	28	BLANK	1268
160/200	-	-	-	315L	508	120	630	630	508	726	216	315	45	815	28	BLANK	1288
-	160/200	110/132	90/110	315L	508	120	630	630	508	726	216	315	45	815	28	BLANK	1318
250	-	-	-	355M	610	116	730	710	560	820	254	355	52	1010	28	BLANK	1500
-	250(D)	160/200	132/160	355M	610	116	730	710	560	820	254	355	52	1010	28	BLANK	1530
315	-	-	-	355L	610	116	730	710	630	820	254	355	52	1010	28	BLANK	1500
-	315(D)	250	200	355L	610	116	730	710	630	820	254	355	52	1010	28	BLANK	1530
-	355/400 450/500	315/355 400/450	250/315 355	400L	686	150	840	826	710	1075	280	400	55	1160	35	BLANK	1910

# OUTLINE DIMENSIONS

## CAST IRON TEFC THREE PHASE SQUIRREL CAGE INDUCTION MOTORS Te3 FRAMES 80 - 400L FOOT AND "D" FLANGE MOUNT

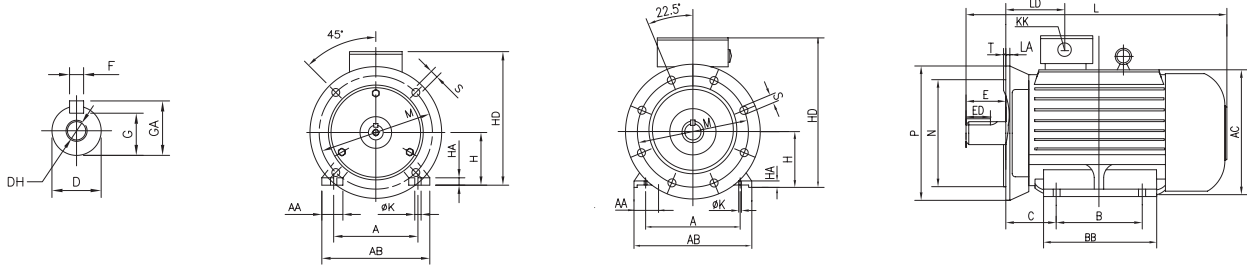

FRAME SIZE								SHAFT EXTENSION							BEARINGS	
	LA	LD	M	N	P	S	T	D	E	ED	F	G	GA	DH	DE	NDE
80	12	76	165	130	200	12	3.5	19	40	22	6	15.5	21.5	M6x12	6204ZZ	6204ZZ
90S	12	75	165	130	200	12	3.5	24	50	32	8	20	27	M8x16	6205ZZ	6205ZZ
90L	12	75	165	130	200	12	3.5	24	50	32	8	20	27	M8x16	6205ZZ	6205ZZ
100L	13	83	215	180	250	15	4	28	60	40	8	24	31	M10x20	6206ZZ	6206ZZ
112M	14	87	215	180	250	15	4	28	60	40	8	24	31	M10x20	6206ZZ	6206ZZ
132S	14	102	265	230	300	15	4	38	80	56	10	33	41	M12x24	6208ZZ	6208ZZ
132M	14	102	265	230	300	15	4	38	80	56	10	33	41	M12x24	6208ZZ	6208ZZ
160M	15	142	300	250	350	19	5	42	110	80	12	37	45	M16x32	6309ZZ (6209ZZ)	6209ZZ
160L	15	142	300	250	350	19	5	42	110	80	12	37	45	M16x32	6309ZZ (6209ZZ)	6209ZZ
180M	15	164	300	250	350	19	5	48	110	80	14	42.5	51.5	M16x32	6311 (6211)	6211
180L	15	164	300	250	350	19	5	48	110	80	14	42.5	51.5	M16x32	6311 (6211)	6211
200L	17	191	350	300	400	19	5	55	110	80	16	49	59	M20x40	6312 (6212)	6212
225S(4-8)	20	191	400	350	450	19	5	60	140	100	18	53	64	M20x40	6313	6312
225M(2)	20	197	400	350	450	19	5	55	110	80	16	49	59	M20x40	6312	6312
225M(4-8)	20	197	400	350	450	19	5	60	140	100	18	53	64	M20x40	6313	6312
250M(2)	22	215	500	450	550	19	5	60	140	100	18	53	64	M20x40	6313	6313
250M(4-8)	22	215	500	450	550	19	5	65	140	100	18	58	69	M20x40	6314	6313
250M(75**)	22	215	500	450	550	19	5	70	140	110	20	62.5	74.5	M20x40	6315	6313
280S(2)	22	221	500	450	550	19	5	65	140	100	18	58	69	M20x40	6314	6314
280S(4-8)	22	221	500	450	550	19	5	75	140	100	18	67.5	79.5	M20x40	6317	6314
280M(2)	22	221	500	450	550	19	5	65	140	100	18	53	69	M20x40	6314	6314
280M(4-8)	22	221	500	450	550	19	5	75	140	100	20	67.5	79.5	M20x40	6317	6314
280M(110**)	22	221	500	450	550	19	5	80	170	140	22	71	85	M20x40	6317	6314
315S(2)	22	257	600	550	660	24	6	65	140	100	18	58	69	M20x40	6317	6317
315S(4-8)	22	257	600	550	660	24	6	80	170	100	22	71	85	M20x40	6319	6319
315M(2)	22	257	600	550	660	24	6	65	140	100	18	58	69	M20x40	6317	6317
315M(4-8)	22	257	600	550	660	24	6	80	170	100	22	71	85	M20x40	6319	6319
315L(2)	22	257	600	550	660	24	6	65	140	100	18	58	69	M20x40	6317	6317
315L(4-8)	22	257	600	550	660	24	6	80	170	100	22	71	85	M20x40	6319	6319
355M(2)	25	284	740	680	800	24	6	75	140	100	20	67.5	79.5	M20x40	6319	6319
355M(4-8)	25	284	740	680	800	24	6	95	170	130	25	85	99	M20x40	6322	6322
355L(2)	25	284	740	680	800	24	6	75	140	100	20	67.5	79.5	M20x40	6319	6319
355L(4-8)	25	284	740	680	800	24	6	95	170	130	25	86	100	M20x40	6322	6322
400L(4-8)	32	425	940	880	1000	28	6	110	210	130	28	90	106	M20x40	6324	6324

Notes: 1. Dimensional data subject to change without notice. 2. Lifting facilities provided on motors frame size D100 and larger. 3. For tolerances see page 11. 4. Bearing numbers in brackets apply to 2 pole motors. 5. \*\*Frame allocations available for 110kw 2 pole, 75kw and 110kw 4 pole.



# OUTLINE DIMENSIONS

## CAST IRON TEFC 3 - PHASE SQUIRREL CAGE INDUCTION MOTORS Te3 FRAMES 80 - 132 FOOT AND "C" FLANGE MOUNT

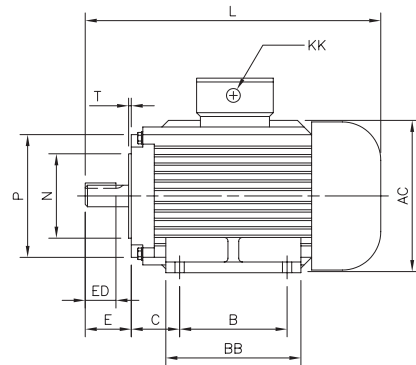
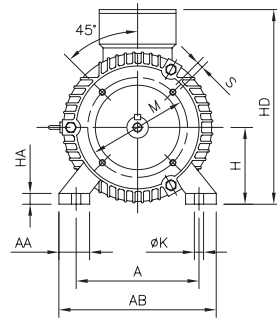
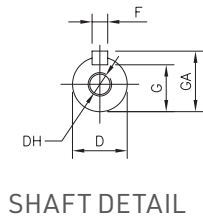

OUTPUT KW				FRAME SIZE	A	AA	AB	AC	B	BB	C	H	HA	HD	K	KK	L
2P	4P	6P	8P														
0.75/1.1	0.55/0.75	0.55	-	80	125	34	160	180	100	130	50	80	10	235	10	M25x1.5	300
1.5	1.1	0.75	-	90S	140	36	180	185	100	180	56	90	12	255	10	M25x1.5	355
2.2	1.5	1.1	-	90L	140	36	180	185	125	155	56	90	12	255	10	M25x1.5	385
3	2.2/3	1.5	0.75/1.1	100L	160	40	200	210	140	176	63	100	14	280	12	M32x1.5	430
4	4	2.2	1.5	112M	190	45	230	220	140	180	70	112	15	305	12	M32x1.5	460
5.5/7.5	5.5	3	2.2	132S	216	55	270	275	140	186	89	132	18	345	12	M32x1.5	495
-	7.5	4/5.5	3	132M	216	55	270	275	178	224	89	132	18	345	12	M32x1.5	535

FRAME SIZE						SHAFT EXTENSION							BEARINGS	
	M	N	P	S	T	D	E	ED	F	G	GA	DH	DE	NDE
80	100	80	120	M6	3.0	19	40	22	6	15.5	21.5	M6x12	6204ZZ	6204ZZ
90S	115	95	140	M8	3.0	24	50	32	8	20	27	M8x16	6205ZZ	6205ZZ
90L	115	95	140	M8	3.0	24	50	32	8	20	27	M8x16	6205ZZ	6205ZZ
100L	130	110	160	M8	3.5	28	60	40	8	24	31	M10x20	6206ZZ	6206ZZ
112M	130	110	160	M8	3.5	28	60	40	8	24	31	M10x20	6206ZZ	6206ZZ
132S	165	130	206	M10	3.5	38	80	56	10	33	41	M12x24	6208ZZ	6208ZZ
132M	165	130	206	M10	3.5	38	80	56	10	33	41	M12x24	6208ZZ	6208ZZ

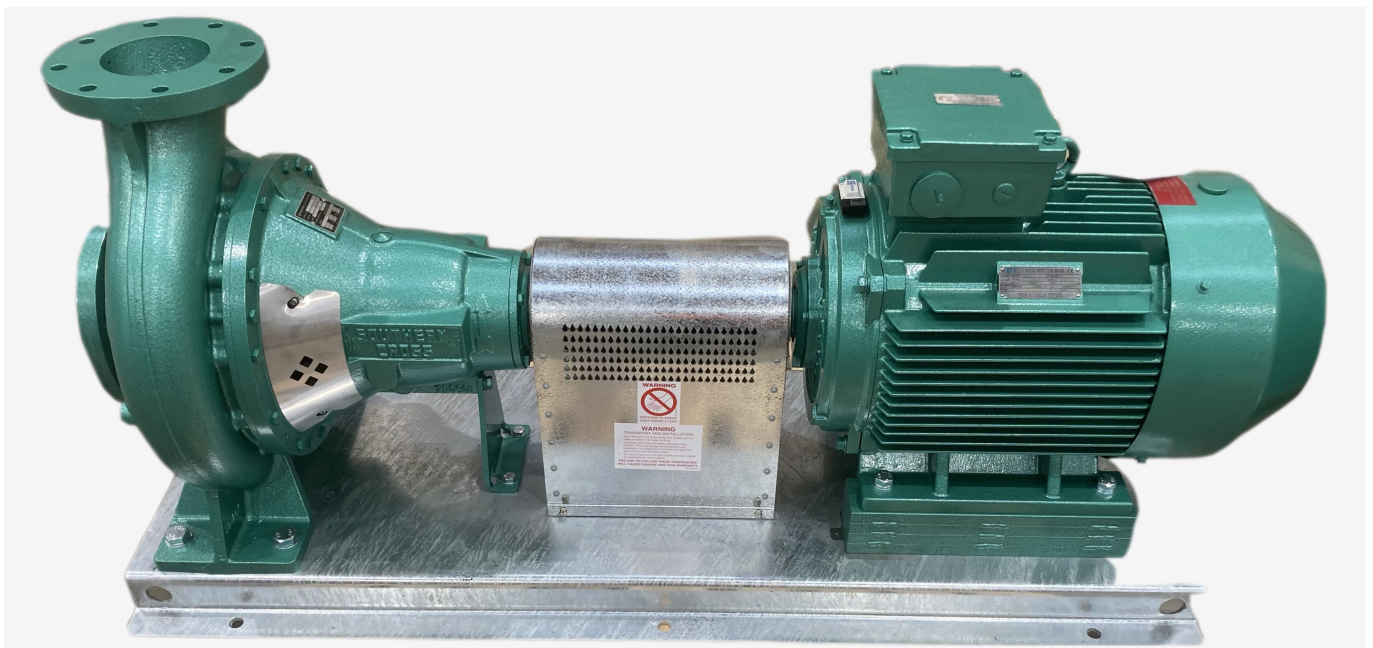

## OUTLINE DIMENSIONS

### Te3 CAST IRON SLIDE RAILS

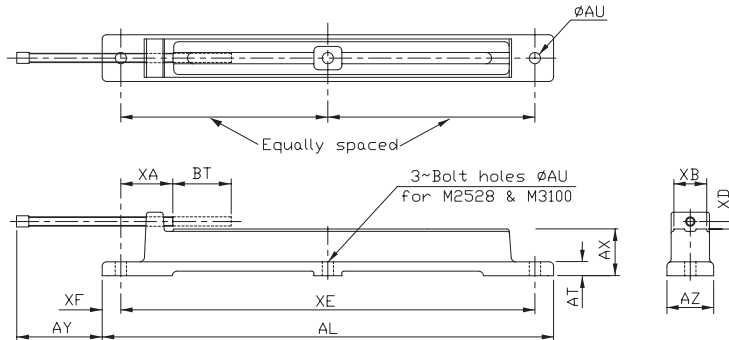

SLIDE RAIL	FRAME SIZE	AL	AT	AU	AX	AY	AZ	BT min.	XA max.	XB	XD	XE	XF
M0809	80	355	12	10	30	105	35	95	45	30	6	325	15
	90	355	12	10	30	105	35	80	45	30	6	325	15
M1013	100	470	16	12	44	170	52	160	50	43	6	430	18
	112	470	16	12	44	170	52	125	50	43	6	430	18
M1618	132	470	16	12	44	170	52	100	50	43	6	430	18
	160	615	19	15	64	170	76	155	67	57	11	565	25
M2022	180	615	19	15	64	170	76	125	67	57	11	565	25
	200	780	25	19	82	210	100	190	80	82	12	725	27
M2528	225	780	25	19	82	210	100	140	80	82	12	725	27
	250	965	30	24	100	275	100	250	86	82	16	885	40
M3100	280	965	30	24	100	275	100	190	86	82	16	885	40
	315	1215	40	38	125	380	123	330	110	95	20	1115	50

### TOLERANCES

D	F	G & H	K	N	S	T	
19≤D≤28	+0.009 -0.004	F=6 +0, -0.03	G=15.5 +0 -0.10	K=10 +0.360 +0	N=80 +0.012 +0.007	12≤S≤15 +0.430 +0	T=3 +0 -0.100
38≤D≤48	+0.018 +0.002	8≤F≤10 +0, -0.036	20≤G≤90 +0 -0.20	12≤K≤15 +0.430 +0	95≤N≤110 +0.013 +0.009	19≤S≤28 +0.520 +0	3.5≤T≤5 +0 -0.120
55≤D≤80	+0.030 +0.011	12≤F≤18 +0, -0.043	80≤H≤250 +0 -0.5	19≤K≤28 +0.520 +0	130≤N≤180 +0.014 +0.011		T=6 +0 -0.150
95≤D≤100	+0.035 +0.013	20≤F≤28 +0, -0.052	280≤H≤400 +0 -1.0	K=35 +0.620 +0	230≤N≤250 +0.016 +0.013		

Notes: 1. Dimensional data subject to change without notice. 2. Lifting facilities provided on motors frame size D100 and larger.





# Te3 Low Voltage 3-Phase Induction Motors

PRODUCT CATALOGUE JUNE 2024

## HEAD OFFICE AUSTRALIA

### TECO Australia Pty Limited

335-337 Woodpark Road,  
Smithfield NSW 2164

P: +61 2 9765 8118

F: +61 2 9765 8185

E: [sales.nsw@teco.com.au](mailto:sales.nsw@teco.com.au)

W: [www.teco.com.au](http://www.teco.com.au)

## VIC/SA/TAS

### TECO Australia Pty Limited

16 Longstaff Road,  
Bayswater VIC 3153

P: +61 3 9720 4411

E: [vicsales@teco.com.au](mailto:vicsales@teco.com.au)

## WA

### TECO Australia Pty Limited

18 Hazelhurst Street,  
Kewdale WA 6105

P: +61 8 9479 4879

E: [sales.wa@teco.com.au](mailto:sales.wa@teco.com.au)

## QLD

### TECO Australia Pty Limited

50 Murdoch Circuit,  
Acacia Ridge QLD 4110

P: +61 7 3373 9600

E: [sales.qld@teco.com.au](mailto:sales.qld@teco.com.au)

## NEW ZEALAND

### TECO New Zealand Ltd

4 Autumn Place,  
Penrose Auckland 1061

P: +64 9 526 8480

E: [sales@teco.co.nz](mailto:sales@teco.co.nz)